

Model JH9010 Hillco Leveling System
For Serial Numbers JH9010-13001 thru JH9010-13999



Model JH9010 Hillside Leveling System Parts Manual

SN JH9010-13001 thru JH9010-13999

For John Deere S680 & S690
S Series Combines

D-120613CMA01B



JH9010 Hillside Leveling System
For S680 & S690 S Series Combines

Table of Contents

General Information	3
Serial Number Location	3
Text and Illustrations	3
Abbreviations	3
Right and left Identification	3
Part Orders	3
Transition	4
Transition Throat	5
Transition Beater Drive	7
Radial Pin Slip Clutch	9
Transition Middle/Tilt Sensor	10
Transition Header Adapter	12
Carriage	13
Overcarriage	14
Undercarriage	16
Carriage Misc. Parts	17
Carriage Position Sensor	18
Drive Wheel	20
Drop Axle	21
Hydraulic Components	22
Cross Port Relief	23
Dual Station Manifold	24
John Deere Header Lift Manifold Fittings	26
Retractable Ladder	28
Ladder Wedge	30
Electrical	32
Controller/Wiring Harnesses	32
Monitor	33
Decals and Literature	34

Contact Information

Hillco Technologies, Inc.
 107 1st Avenue
 Nezperce, Idaho 83543

Phone	800-937-2461
	208-937-2461
Fax	208-937-2280

www.hillcotechnologies.com
 email: support@hillcotechnologies.com

GENERAL INFORMATION

SERIAL NUMBER LOCATION

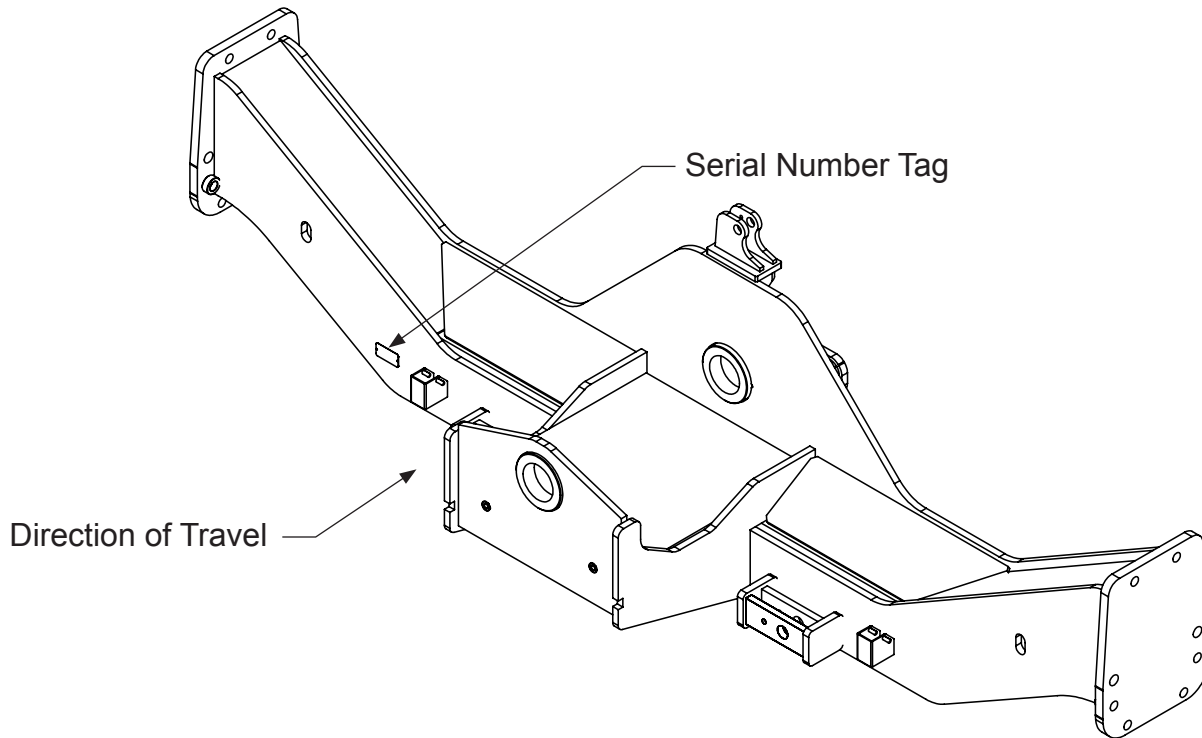

TEXT AND ILLUSTRATIONS

The arrangement of this parts catalog is for easy identification of parts. All parts are illustrated in exploded views in proper relation to each other. Some diagrams refer to other pages for further information. Reference numbers used in the illustrations refer to line numbers in the part lists. The part lists appear to the right or below all diagrams and correspond with those diagrams. Included in the part lists, along with the reference numbers are part numbers, part descriptions and the quantity of the part required per leveling system.

ABBREVIATIONS

SN "Serial Number" refers to the serial number given to each leveling system (by Hillco Technologies), as well as the serial number given to the combine (by the specific combine manufacturer) the leveling system is installed. See above for the leveling system's serial number location. This abbreviation is used interchangeably in both instances. Each Model JH9010 Leveling System uses the following serial number format: JH9010-XXXXX (sequential numbers).

ASM "Assembly" refers to a whole grouping of parts (shown in the diagram corresponding with the page where "ASM" is shown unless otherwise noted). Some assemblies have parts that are sold separately, however some must be purchased as a single unit. Hillco Product Specialists will be able to assist you with any questions.

NS "Not Shown" refers to a part that is not depicted in the illustration.

RIGHT AND LEFT IDENTIFICATION

The reference to right-hand and left-hand in this catalog is identified by the operator sitting in the operator's seat, looking toward the front of the machine (in normal forward travel).

PART ORDERS

Orders must specify product model, serial number, correct part number, complete description, quantity required, method of shipment, shipping address, and billing address.

TRANSITION

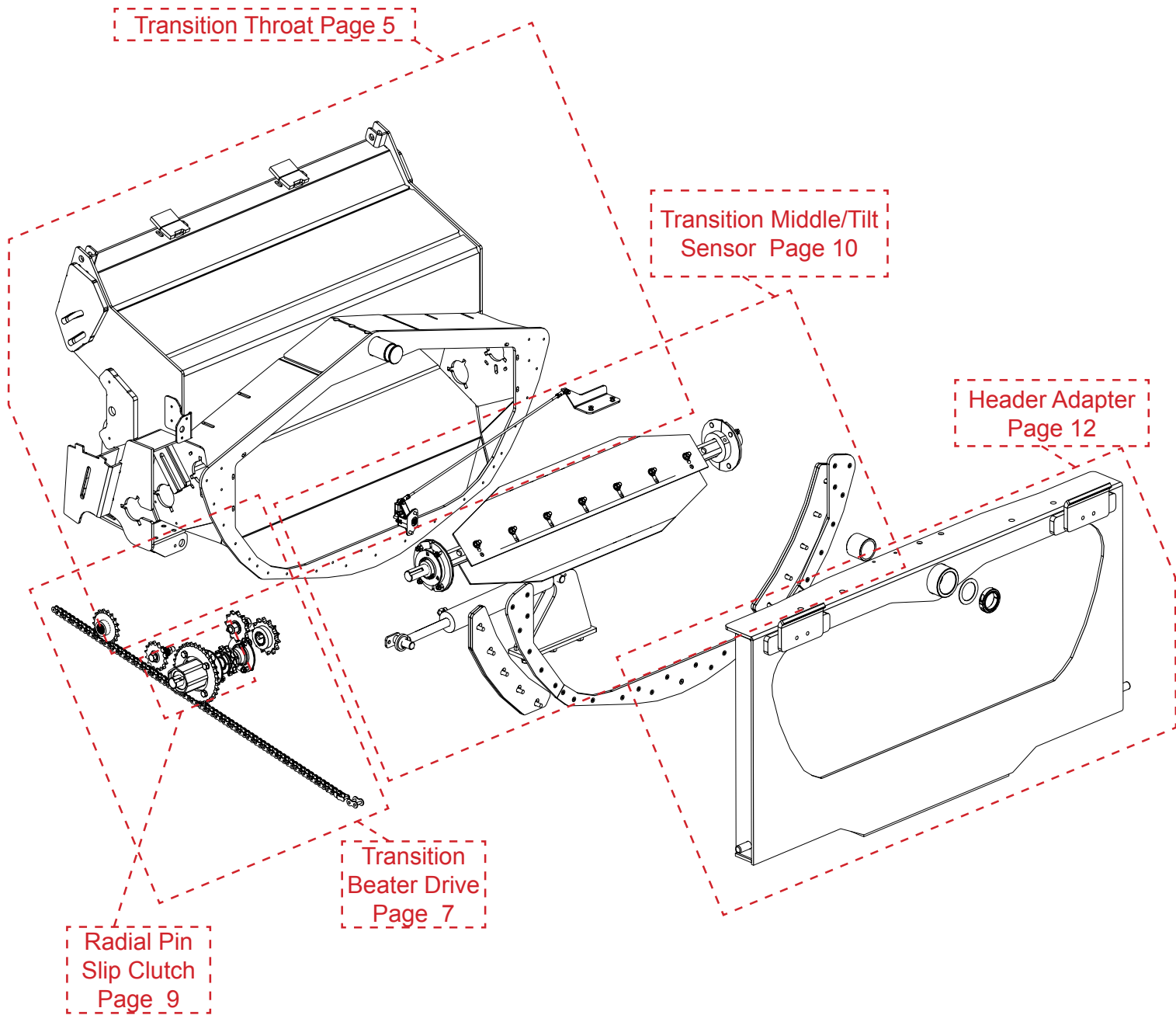

Model JH9010 Hillco Leveling System
For Serial Numbers JH9010-13001 thru JH9010-13999

TRANSITION THROAT

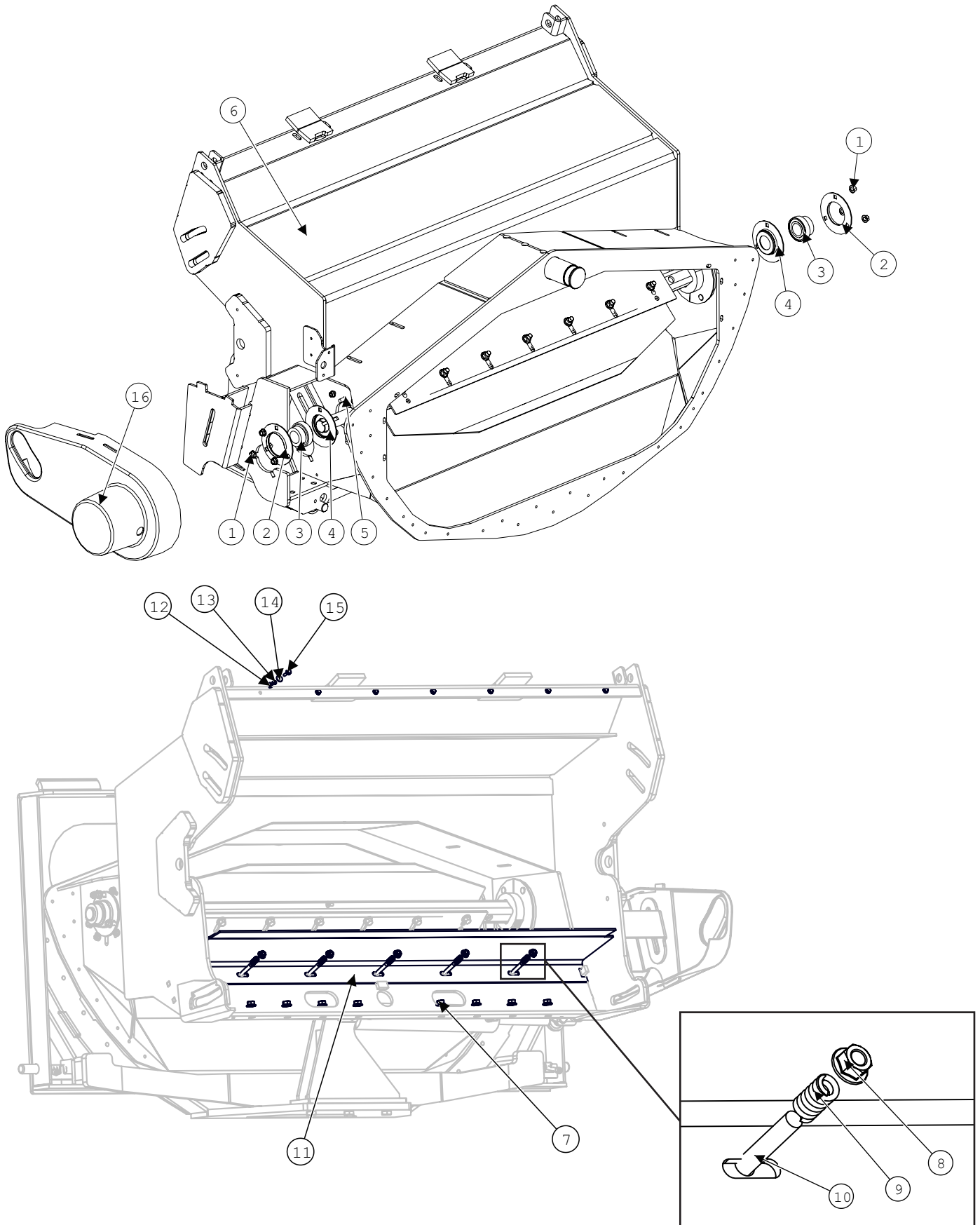

Model JH9010 Hillco Leveling System
For Serial Numbers JH9010-13001 thru JH9010-13999

Transition Throat			
BOM ID	Part No.	Qty	Description
1	F-HNF-10ME	6	FLHN-10.9 M10 X 1.50
2	MC-101339 HALF	2	FLANGETTE, ROUND BEARING
3	MC-100548	2	INSERT, BEARING 1-7/16"
4	LA-243691	2	TM ASM, INNER FLANGETTE
5	F-CB-10M030F	3	CARR-8.8M10X1.5X30 HEAD SCREW
6	LW-297151	1	TT ASM THROAT
7	F-HNF-12ME	16	FLHN-10.9 M12 x 1.75 PLT
8	F-HNSF-10ME	5	FLHN-10.9 M10X1.5 STV
9	MC-143591	5	SPRING, C .703DX1.09LX.125W
10	F-CB-10M060F	5	CARR-8.8M10X1.5X60
11	LP-271691	1	TT PLT, FLEX FLOOR REAR
12	F-HNF-06ME	7	FLHN-10.9M6X1.00
13	F-LW-04	7	LW, SPRING, 1/4"
14	F-FW-04	7	WASHER, FLAT 1/4
15	F-HCF-06M020F	7	FLHC-8.8M6X1.0X20
16	MC-147671	1	TM SHIELD, FRONT BEATER DRIVE

TRANSITION BEATER DRIVE

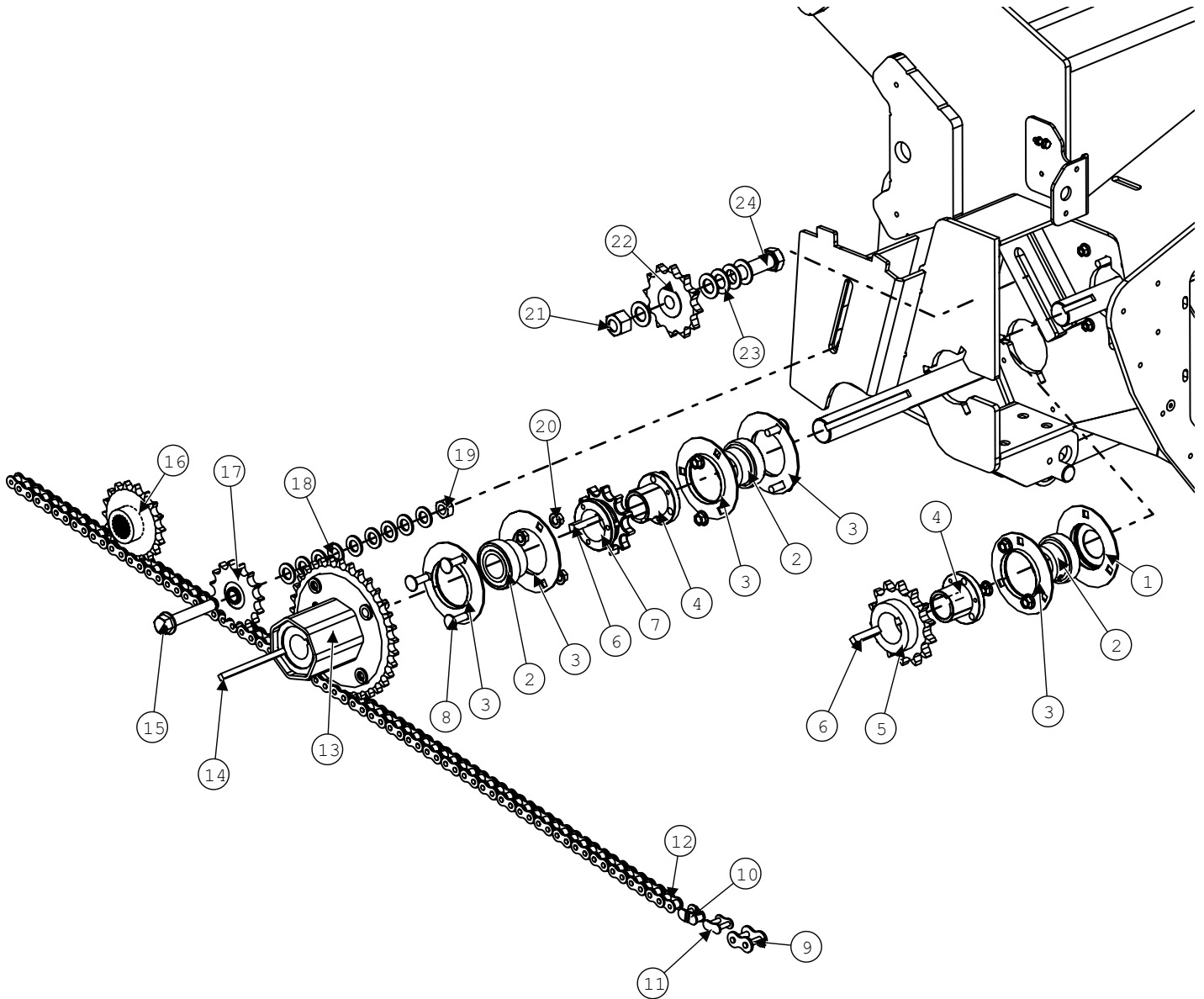

Model JH9010 Hillco Leveling System
For Serial Numbers JH9010-13001 thru JH9010-13999

Transtion Beater Drive			
BOM ID	Part No.	Qty	Description
1	LA-243691	1	TM ASM, INNER FLANGETTE
2	MC-100548	3	INSERT, BEARING 1-7/16"
3	MC-101339	5	FLANGETTE, ROUND BEARING
4	MC-135511	2	HUB, SPLIT TAPER 1-7/16
5	MC-136151	1	SPROCKET, 80P, 14T TAPER BORE
6	F-KST-06X06X32	2	TM KEY, BEATER DRIVE
7	MC-135491	1	SPROCKET 80P, 11T TB
8	F-CB-10M030F	6	CARR-8.8M10X1.5X30 HEAD SCREW
NS	LP-232162	1	TM CHAIN, 28 PIN 80P
9	MC-139341	1	LINK, CONNECTING, 80P
10	MC-139371	1	LINK, OFFSET, 60P
11	MC-139361	1	LINK, CONNECTING, 60P
12	LP-255132	1	TM CHAIN, 70PIN 60P
13	LA-242431	1	SLIP CLUTCH ASM, RADIAL PIN; SEE NEXT PAGE
14	F-KST-05X05X80	1	TM KEY, RADIAL SLIP CLUTCH
15	F-HCF-16M090E	1	FLHC-10.9 M16X2.0X090
16	LA-273851	1	TM ASM, DRIVE SPROCKET
17	MC-100237	1	SPROCKET, IDLER, 60P, 15T, 5/8B
18	F-FWH-10	10	WASHER, FLAT, 5/8
19	F-HNS-16ME	1	HN-10.9M16X2.0 STV
20	F-HNF-10ME	9	FLHN-10.9 M10 X 1.50
21	F-HNS-20ME	1	HC-10.9M20X2.5 STOVER
22	MC-137441	1	SPOCKET, IDLER 80P, 12T, 3/4
23	F-FWH-12	5	FW 3/4
24	F-HC-20M070E	1	HC-10.9 M20 2.50 X 70 PLT

RADIAL PIN SLIP CLUTCH

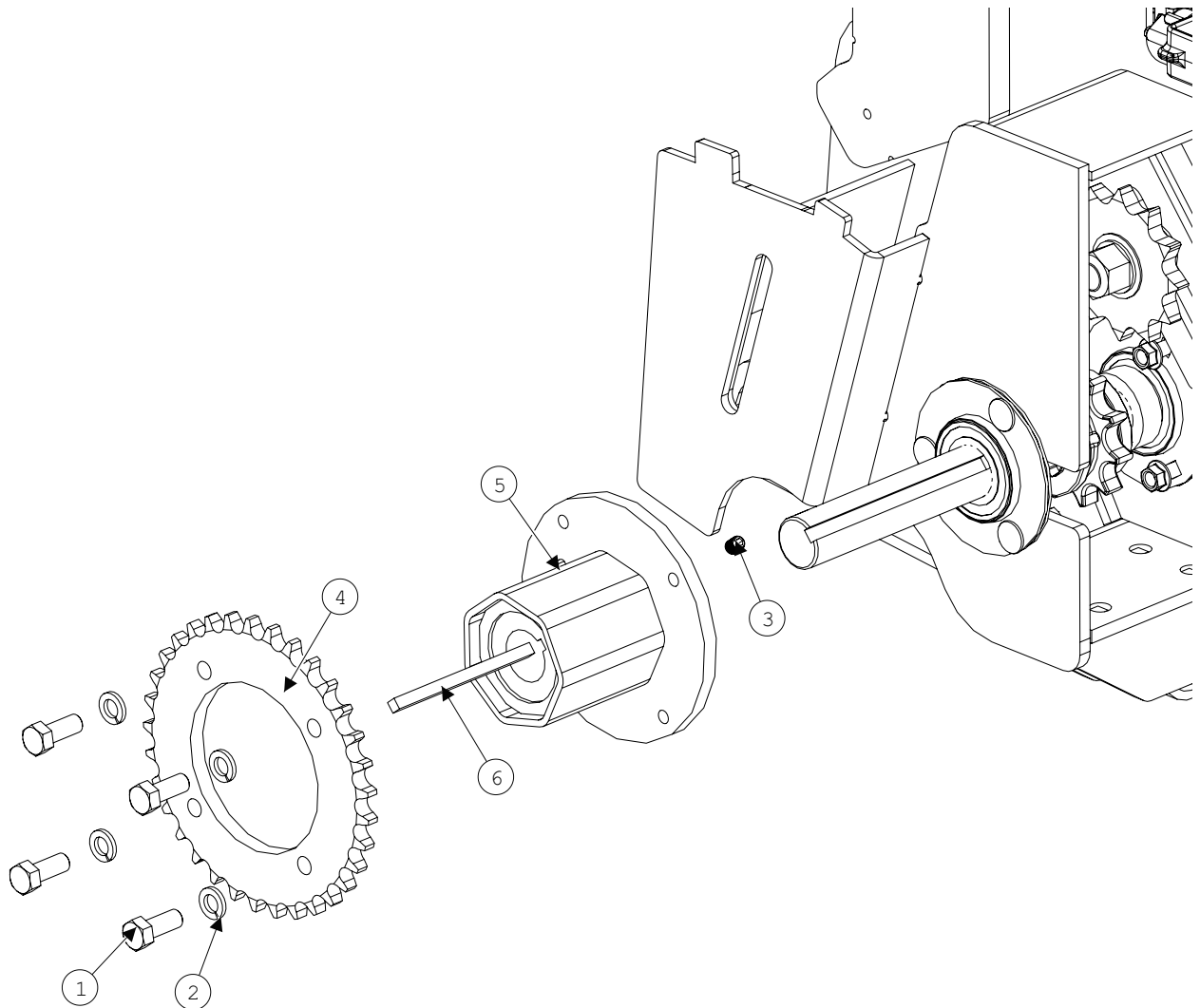

Radial Pin Slip Clutch			
BOM ID	Part No.	Qty	Description
ASM	LA-242431	1	SLIP CLUTCH ASM, RADIAL PIN
1	F-HC8-08F20	4	HC8 1/2-20x1-1/4
2	F-LW-08A	4	LW 1/2 HD
3	F-SSS-06C08	1	SCREW, SOCKET SET 3/8-16x1/2
4	LM-226532	1	TM SPROCKET, RADIAL SLIP CLUTCH
5	MC-136921	1	SLIP CLUTCH, RADIAL 1-7/16B&5/16 KEY
6	F-KST-05X05X80	1	TM KEY,SQ 1018 CD 5/16" X 5"

Model JH9010 Hillco Leveling System
For Serial Numbers JH9010-13001 thru JH9010-13999

TRANSITION MIDDLE/TILT SENSOR

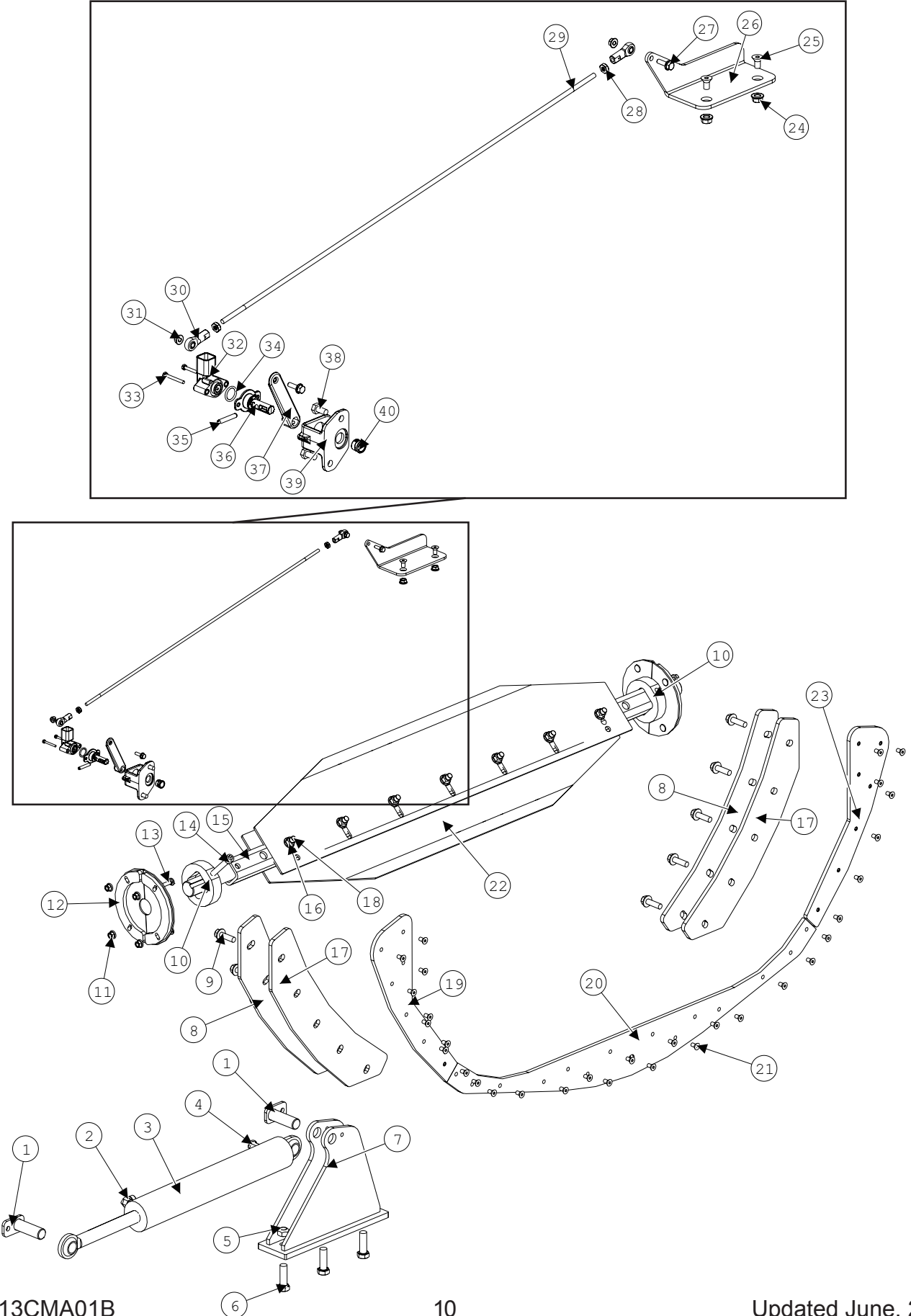

Model JH9010 Hillco Leveling System
For Serial Numbers JH9010-13001 thru JH9010-13999

Transition Middle/Tilt Sensor				
BOM ID	HILLCO Part No.	JOHN DEERE Part No.	Qty	Description
1	LA-229071	-	2	TM PIN ASM, BASE END
2	HA-L-6MF6MO	-	1	ELBOW, 90°, 6MF x 6MO
3	HC-147491	-	1	CYL, 1-1/8" R, 12-1/2" S, 2-1/2 B, 21" CPC
4	HA-F-6MF6MO	-	1	#6 MORS X #6 MORB 45 DEG
5	F-HNS-16ME	-	3	HN-10.9M16X2.0 STV
6	F-HC-16M50E	-	3	HC-10.9M16X2.00X50
7	LA-229023	-	1	TM MOUNT ASM, ROD
8	LP-249861	-	2	TM PLT, BACKING
9	F-HCF-12M040E	-	10	FLHC-10.9 M12 X 1.75 X 40 PLT
10	LM-286331	-	2	TT PLT, SHAFT SEAL
11	F-HNFS-08ME	-	8	FLHN-10.9M08X1.25 STOVER
12	LA-286311	-	4	TT ASM, CAN
13	F-CB-08M035F	-	8	CARR-8.8M8X1.25X35 HEAD SCREW
14	F-SHC-12M075E	-	2	SHCS-12.9M12x75
15	LA-251632	-	1	TB ASM, SHAFT
16	F-HNFS-12ME	-	7	FLHN-10.9M12X1.75 STVR
17	LP-249871	-	2	TM UHMW, BACKING
18	F-HCF-12M080E	-	7	MM FLHC-10.9 M12 X 1.75 X 80 Plated
19	LM-229162	-	1	TM PLT, WEAR LH
20	LM-229152	-	1	TM PLT, WEAR BOTTOM
21	F-FHS-8M016E	-	32	FHSC-10.9M8X1.25X016
22	LB-286321	-	2	TB PADDLE, METAL (NARROW)
23	LM-229172	-	1	TM PLT, WEAR RH
24	F-HNF-08ME	-	2	FLHN 10.9 M8 X 1.25
25	F-FHS-8M016E	-	2	FHSC-10.9M8X1.25X016
26	LB-296192	-	1	TA MNT, SENSOR LINK
27	F-HCF-06M020F	-	2	FLHC-8.8M6X1.0X20
28,29,30	LA-295572	-	1	TT ASM, SENSOR LINKAGE
28	F-HNJF-04C	-	2	NUT, JAM 1/4-28
29	LS-295502	-	1	TM ROD, SENSOR LINK ASSEMBLY
30	MC-151881	-	2	ROD END, BALL JOINT, FEMALE, 1/4-28
31	F-HNF-06ME	-	2	FLHN-10.9M6X1.00
32	EC-151381	AXE14246	1	SENSOR, ROTATION, HALL 2CH +/-120DE
33	F-HC-04M035E	19M9368	2	HC-8.8M4X0.7X035
34	MC-151391	P48347	1	O-RING, 11/16ID
35	F-PR-06Mx36	-	1	PIN, ROLL 6mm x 36mm
36	MC-151401	AXE14888	1	SHAFT, ROUGH SERVICE DEVICE
37	MC-151351	-	1	ARM, TRANSITION SENSOR
38	F-HC-08M016E	-	2	HC-10.9 M8x1.25X16
39	MC-151321	HXE16001	1	BRACKET, SENSOR MNT
40	MC-151361	R41076	1	BUSHING,

Model JH9010 Hillco Leveling System
 For Serial Numbers JH9010-13001 thru JH9010-13999

TRANSITION HEADER ADAPTER

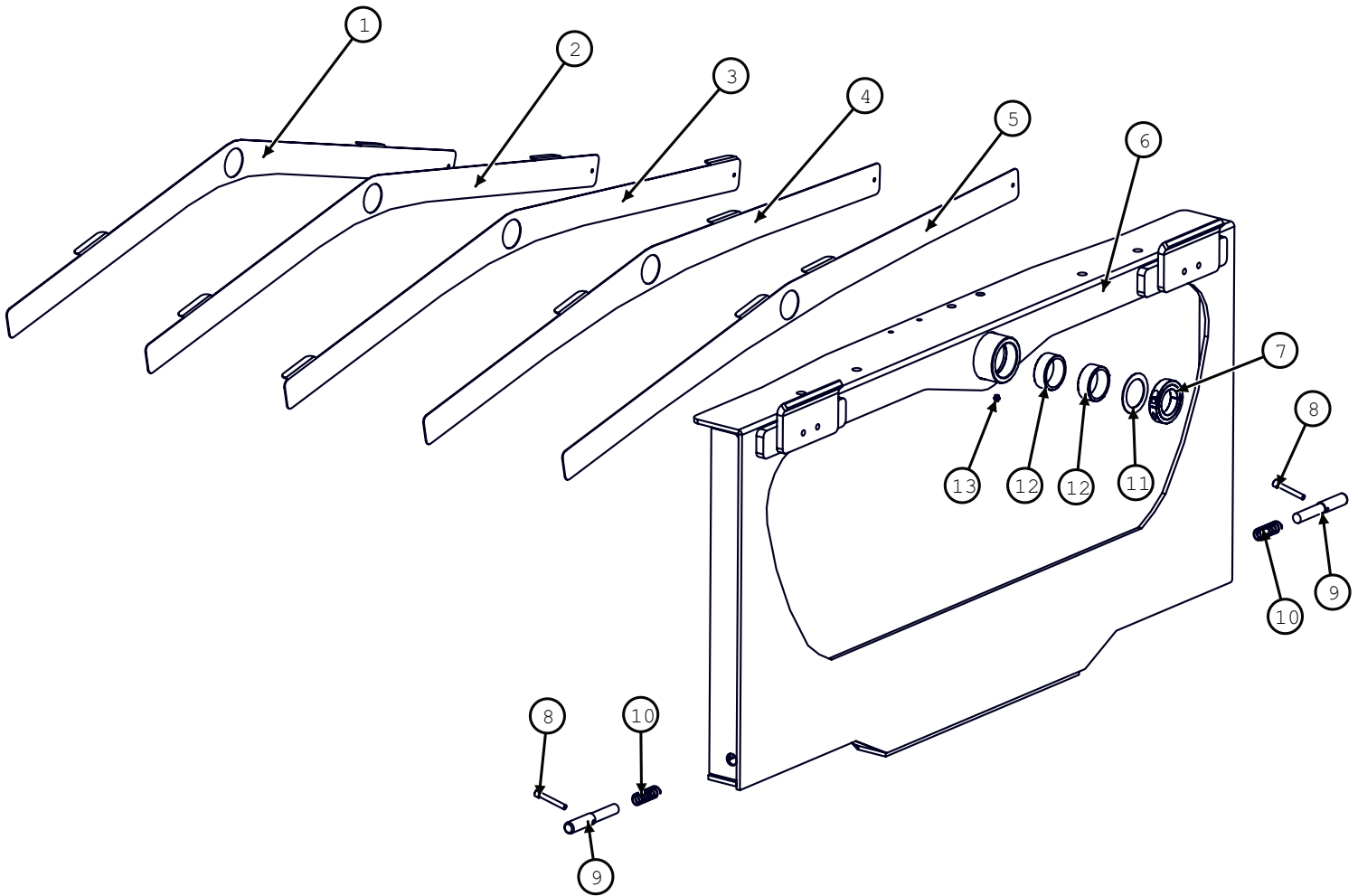

Transition Header Adapter			
BOM ID	Part No.	Qty	Description
1-5	LA-306131	1	TM ASM, DEFLECTOR KIT
1	LB-306181	1	TM SHT, DEFLECTOR, REAR
2	LB-306171	1	TM SHT, DEFLECTOR, INNER REAR
3	LB-306161	1	TM SHT, DEFLECTOR, CENTER
4	LB-306151	1	TM SHT, DEFLECTOR, INNER FRONT
5	LB-306141	1	TM SHT, DEFLECTOR, FRONT
6	LW-306121	1	TA HEADER ADAPTER
7	MC-150742	1	COLLAR,CLAMPING,2-1/2 ID 3-3/4 OD, 2 PIECE HEAVY
8	F-SHC-10M070F	2	SHCS-8.8 10M X 1.50 X 70 PLT
9	LM-229192	2	TM ROD, LOCK
10	MC-135531	2	SPRING, COM, 1"ODx2-7/8"Lx .0625W
11	F-MB-14NR40	1	MACHINE BUSHING 14GAUGE 2-1/2"
12	LP-305471	2	TM BUSHING, PIVOT
13	HC-133891	1	ZERK, GREASE 1/8 NPT STRAIGHT
14	LA-306131	1	TM ASM, DEFLECTOR

Model JH9010 Hillco Leveling System
For Serial Numbers JH9010-13001 thru JH9010-13999

Carriage

Overcarriage
Page 14

Carriage
Position Sensor
Page 18

Misc.
Carriage
Parts
Page 17

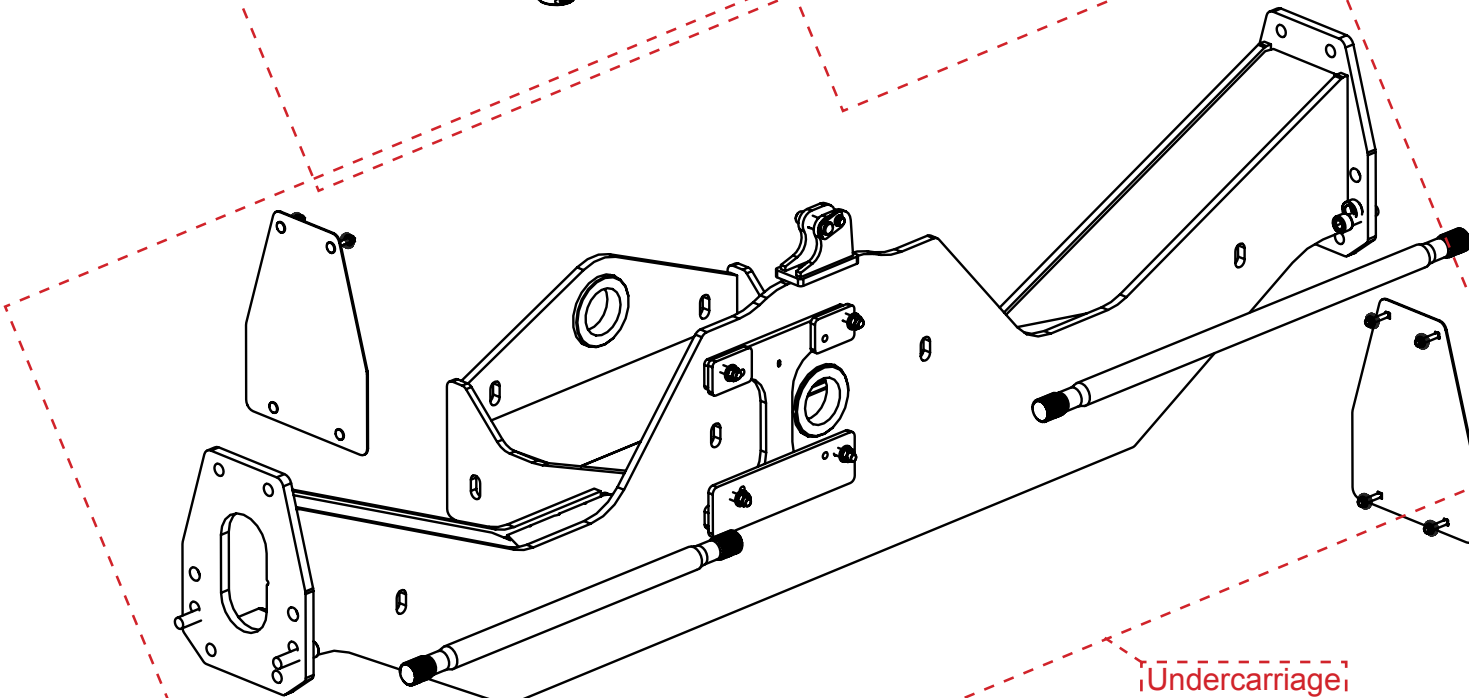
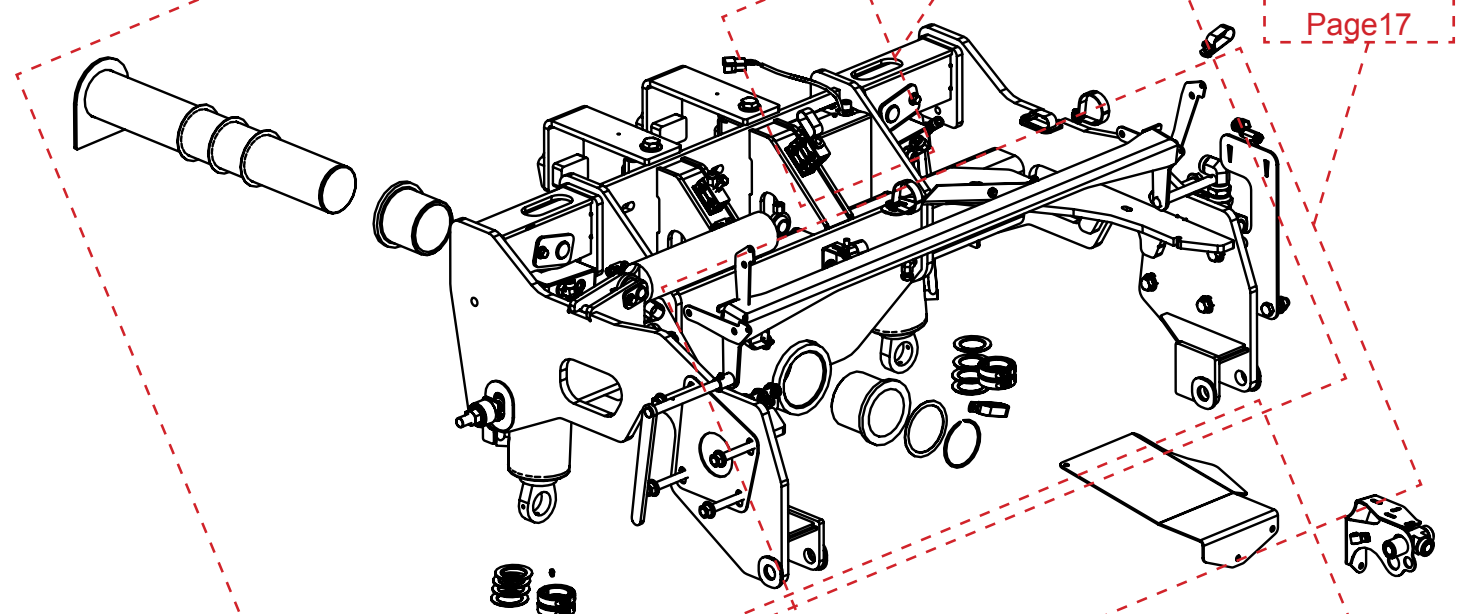

Undercarriage
Page 16

Model JH9010 Hillco Leveling System
For Serial Numbers JH9010-13001 thru JH9010-13999

Overcarriage

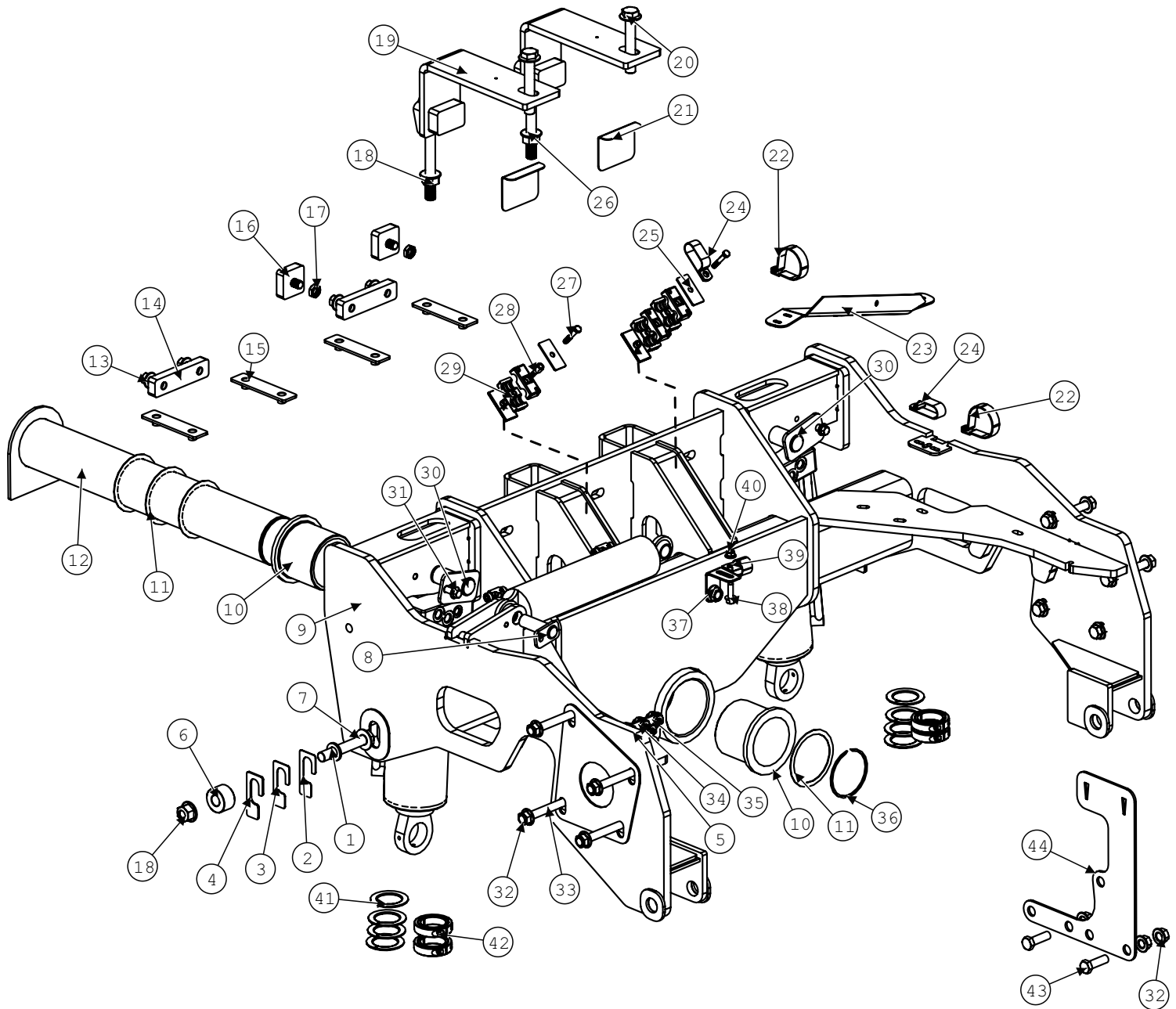

Model JH9010 Hillco Leveling System
For Serial Numbers JH9010-13001 thru JH9010-13999

Overcarriage			
BOM ID	Part No.	Qty	Description
1	F-LWC-14	2	WASHER, LOCK, CONICAL 7/8"
2	LP-276151	2	CM PLT, BODY SHIM 18GA
3	LP-276141	2	CM, PLT, BODY SHIM 14 GA
4	LP-276131	2	CM PLT, BODY SHIM 1/8
5	HC-138011	5	ZERK, GREASE 1/4-28 STR
6	LM-259831	2	CU BUSHING, FINAL BOLT
7	F-HCF-20M120E	2	FLHC-10.9M20X2.5X120
8	LW-293491	1	TM PIN ASM, BASE END
9	LW-291331	1	CO WLD, BASE
10	LP-247961	2	CM BUSHING, PIVOT
11	MC-138641	4	WASHER; 4.016ID X 4.764OD X 0.048
12	LW-291351	1	CM WLD, PIVOT PIN (JS-9010)
13	F-HCF-16M030E	4	FLHC-10.9 M16 X 2.00 X 30
14	LM-291731	2	CO PLT, CARRIAGE LOCK
15	LW-293561	4	CO WLD, LOWER CARRIAGE SHIM (9010)
16	LW-293581	2	CO WLD, UPPER CARRIAGE SHIM (9010)
17	F-HNJ-16MF	2	HN-8.8 M16 X 1.75 JAM PLT
18	F-HNSF-20ME	4	FLHN-10.9M20X2.5 STVR
19	LW-293631	2	CM WLD, AXLE CLAMP (9010)
20	F-HCF-20M120F	2	FLHC-10.9 M20X2.5X120
21	LP-270041	2	CM PLT, CARRIAGE SHIM
22	MC-101343	2	CLAMP, HOSE 2-7/16" R/C W/ 3/8" HOLE
23	LM-274901	1	LM PLT, SUPPORT, HYDRO HOSE
24	MC-147781	2	CLAMP 1/4" DOUBLE LOOP 3/8HOLE
25	HC-139451	2	BEHRINGER TWIN COVER PLT 0.875
26	F-HCF-20M220E	2	FLHC 10.9M20X2.50X220 (JD#19M8988)
27	F-HC5-05C32	2	HC5 5/16-18 X 2
28	HC-139471	1	STACK BOLT, BEHRINGER 5/16-18
29	HC-139431	6	BEHRINGER TWIN CLAMP -.750 DIA
30	LA-230552	2	CM PIN ASM, MAIN CYLINDER
31	F-HCF-12M025E	2	FLHC-10.9M12X1.75X25
32	F-HNF-16ME	13	FLHN-10.9M16X2.0
33	F-HCF-16M110E	8	FLHC-10.9 M16 X 2.00 X 110 PLT
34	HA-NJ-2FN	5	1/8" NPSM BULKHEAD LOCKNUT
35	HA-S-2FP2MN	5	UNION, 1/8" NPSMx1/8" FPT, BULKHEAD
36	MC-138651	1	SNAP RING; 4"
37	LP-276881	1	LM PLT, BRACKET, PRO-DRIVE BRAKE
38	F-HCF-10M030E	1	FLHC 10.9 M10 X 1.5 X 30
39	EC-142101	1	CLAMP, HOSE R/C, 3/8
40	F-HNF-10ME	1	FLHN-10.9 M10 X 1.50
41	MC-137501	8	WASHER, QUICK REPAIR 2"
42	MC-137251	4	COLLAR, 2 PIECE CLAMPING, 2" BORE
43	F-HC-16M050E	2	HC-10.9M16x50
44	LP-297821	1	LM PLT, MANIFOLD SPACER

Model JH9010 Hillco Leveling System
For Serial Numbers JH9010-13001 thru JH9010-13999

Undercarriage

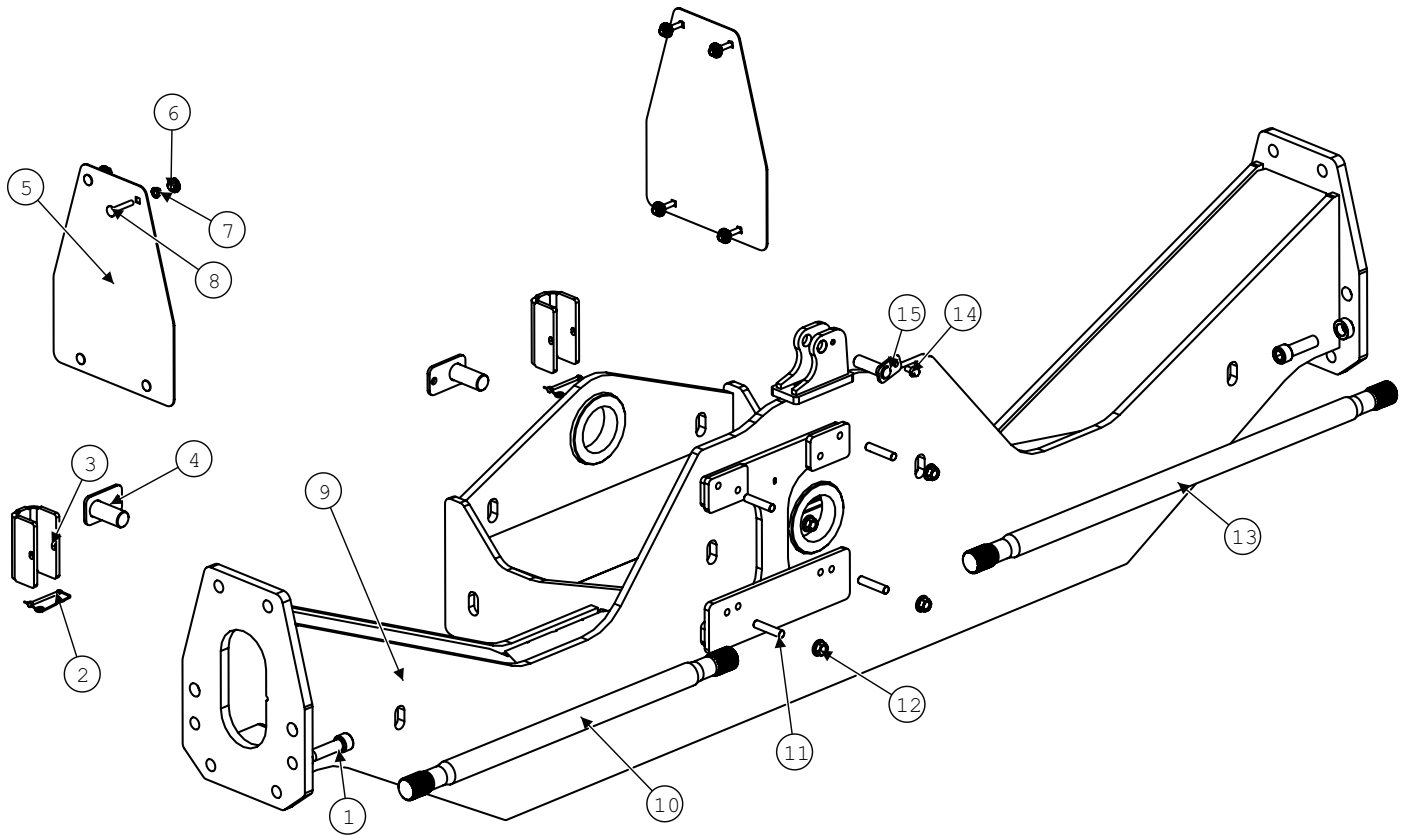

Undercarriage			
BOM ID	Part No.	Qty	Description
1	F-SHC-24M080D	4	SHCS 12.9-M24 X 3 X 80 PLT
2	F-PSL-04X48	2	SNAP LOCK PIN 1/4 X 3
3	LB-306721	2	CM PLT, CYLINDER STOP
4	LA-230552	2	CM PIN ASM, MAIN CYLINDER
5	LP-293831	2	CM SHT, CAP, AXLE
6	MC-151021	8	BUSHING, PLASTIC (JD#Z31550)
7	F-HNF-10ME	8	FLHN-10.9 M10 X 1.50
8	F-CB-10M050F	8	CARR-8.8M10X1.5X50 HEAD SCREW
9	LW-291431	1	CU WLD, UNDERCARRIAGE, 122.5
10	MC-151531	1	SHAFT, DRIVE 951MM
11	F-STD-16M075E	4	STUD, DOUBLE-10.9 M16X2.00X75
12	F-HNF-16ME	4	FLHN-10.9M16X2.0
13	MC-151541	1	SHAFT, DRIVE 1228MM
14	F-HCF-10M020E	1	
15	LW-293491	1	TM PIN ASM, BASE END

Model JH9010 Hillco Leveling System
For Serial Numbers JH9010-13001 thru JH9010-13999

Carriage Misc. Parts

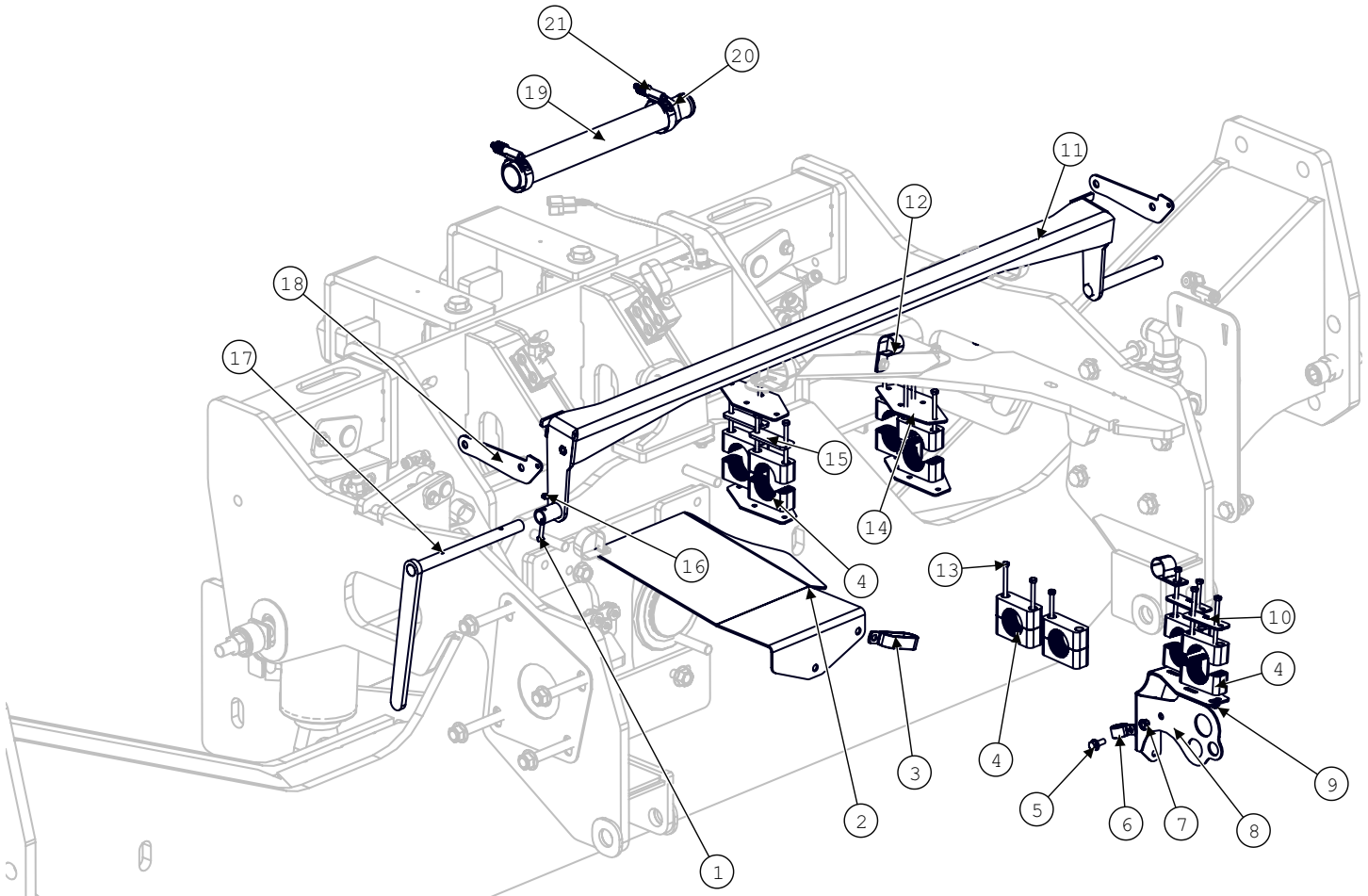

Overcarriage Misc.			
BOM ID	Part No.	Qty	Description
1	F-HC-06M035E	1	HC-10.9 M6x1.0X35
2	LP-274251	1	HM PLT, TABLE HYDRO HOSE
3	MC-151781	1	CLAMP, P-STYLE (JD#AH77884)
4	HC-140641	8	CLAMP, 2" BEHRINGER STD
5	F-HCF-08M020E	1	FLHC-10.9M8X1.25X20
6	HC-135791	1	CLAMP, HOSE 7/8 R/C W 3/8HOLE (JD#AH78237)
7	F-HNF-08ME	1	FLHN-10.9M8X1.25
8	LW-297311	1	LM WLD, HYDRO HOSE SUPPORT
9	F-HNF-06ME	4	FLHN-10.9M6X1.00
10	HC-140651	2	BEHRINGER STD COVER PLATE
11	LA-264511	1	LM ASM, LINKAGE, ROCK TRAP
12	HC-143601	2	CLAMP, HOSE 1-1/8" R/C W 3/8
13	F-HC-06M090F	15	HC-8.8 M6 X 1.00 X 90
14	LP-274231	4	HM PLT, HYDRO HOSE SUPPORT
15	LP-276391	2	HM CLAMP SPACER
16	F-HNN-06MF	1	HN-8.8M6X1.0 NYLOCK
17	LA-264501	1	LM ASM, HANDLE, ROCK TRAP
18	LP-290741	2	LM SHT, ROCK TRAP LINKAGE, UPPER
19	LA-276351	1	HOSE, 1-1/2" BELLOWSFLEX HARDWALL 14"
20	HA-U-24MB24MB	1	UNION, -24MB x -24MB
21	MC-152061	2	CLAMP, HOSE, WORM GEAR, 1.5" TO 2.5"

Model JH9010 Hillco Leveling System
For Serial Numbers JH9010-13001 thru JH9010-13999

Carriage Position Sensor

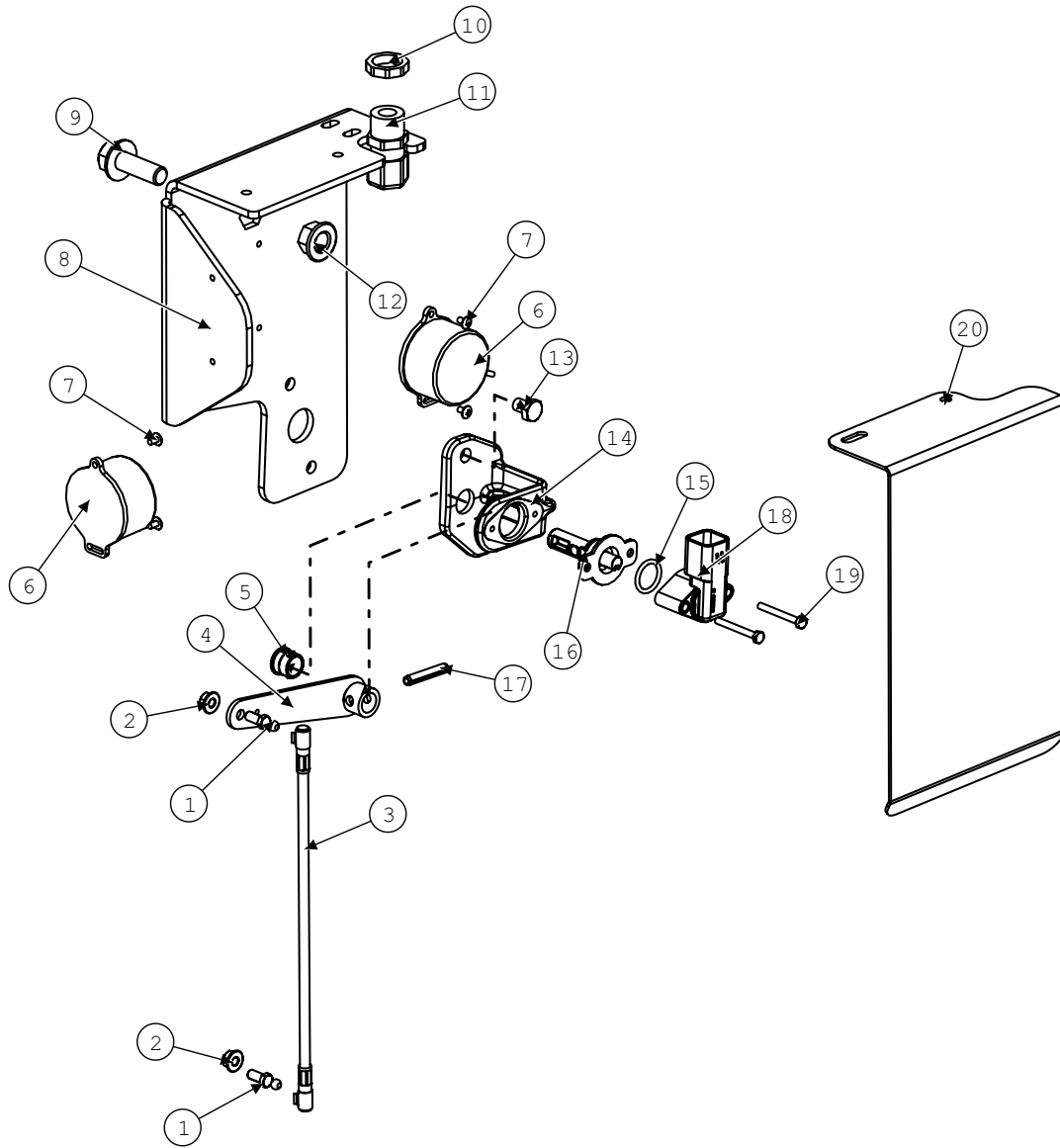

Model JH9010 Hillco Leveling System
For Serial Numbers JH9010-13001 thru JH9010-13999

Carriage Position Sensor				
BOM ID	Hillco Part No.	John Deere Part No.	Qty	Description
1	MC-151341	H168732	2	BALL STUD (H168732)
2	F-HNF-06ME	-	2	FLHN-10.9M6X1.00
3	MC-151331	AH226146	1	LINKAGE, POSITION (AH226146)
4	MC-151371	AXE17303	1	ARM, ASSY, TILT SENSOR, HM (axe17303)
5	MC-151361	R41076	1	BUSHING, (R41076)
6	LA-295431	-	2	EM ASM, CLINOMETER
7	F-PHM-#C604	-	4	PHMS #6-32X1/4
8	LB-295142	-	1	EM SHT, SENSOR MNT, CLINOMETER
9	F-HCF-12M035E	-	1	FLHC 10.9 M12 X 1.75 X 35 PLT
10	EC-142121	-	1	STRAIN RELIEF NUT, 1/2" BLACK
11	EC-138781	-	1	STRAIN RELIEF, NYLON, BLK,
12	F-HNF-12ME	-	1	FLHN-10.9 M12 x 1.75 PLT
13	F-HC-08M010F	19m7008	2	HC-8.8M8X1.25X10 (19m7008)
14	MC-151321	HXE16001	1	BRACKET, SENSOR MNT (HXE16001)
15	MC-151391	P48347	1	O-RING, 11/16ID (P48347)
16	MC-151401	AXE14888	1	SHAFT, ROUGH SERVICE DEVICE (AXE14888)
17	F-PR-06Mx36	-	1	PIN, ROLL 6mm x 36mm
18	EC-151381	AXE14246	1	SENSOR, ROTATION, HALL 2CH +/-120DE (axe14246)
19	F-HC-04M035E	19M9368	2	HC-8.8M4X0.7X035 (19m9368)
20	LB-303151	-	1	EM SHT, SHIELD SENSOR

DRIVE WHEEL

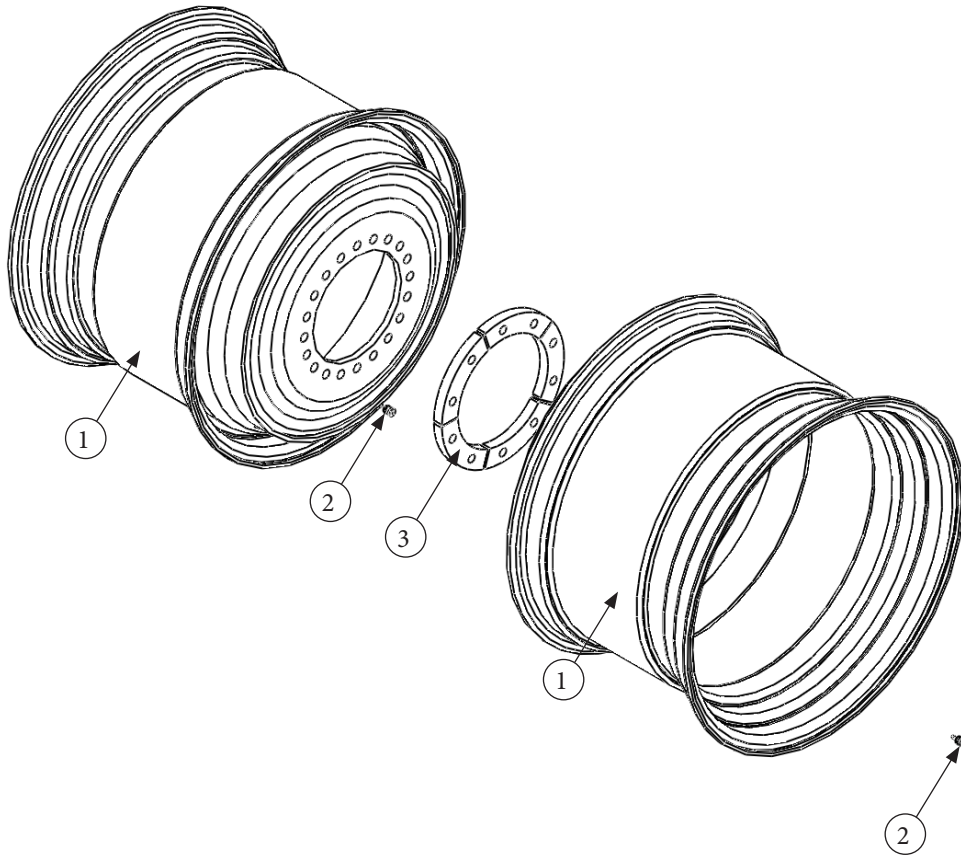

DRIVE WHEEL COMPONENTS				
REF.	PART NO.	QTY.	PART NAME	NOTES
1	MC-143131	4	32 X 21 SINGLE PIECE WHEEL	
2	MC-143921	4	VALVE STEM	
ASM	LA-265961	2	SET, WHEEL CLAMPING RING ASSEMBLY	1 SET PER SIDE
3	LP-260112	10	RING, WHEEL CLAMPING	5 PER SET
STEER WHEEL COMPONENTS				
NS	JD PART NO AXE10349		4 WD REAR WHEEL	JOHN DEERE SUPPLIED PART
NS	JD PART NO AT25226		REAR WHEEL VALVE STEM	JOHN DEERE SUPPLIED PART

Model JH9010 Hillco Leveling System
For Serial Numbers JH9010-13001 thru JH9010-13999

DROP AXLE

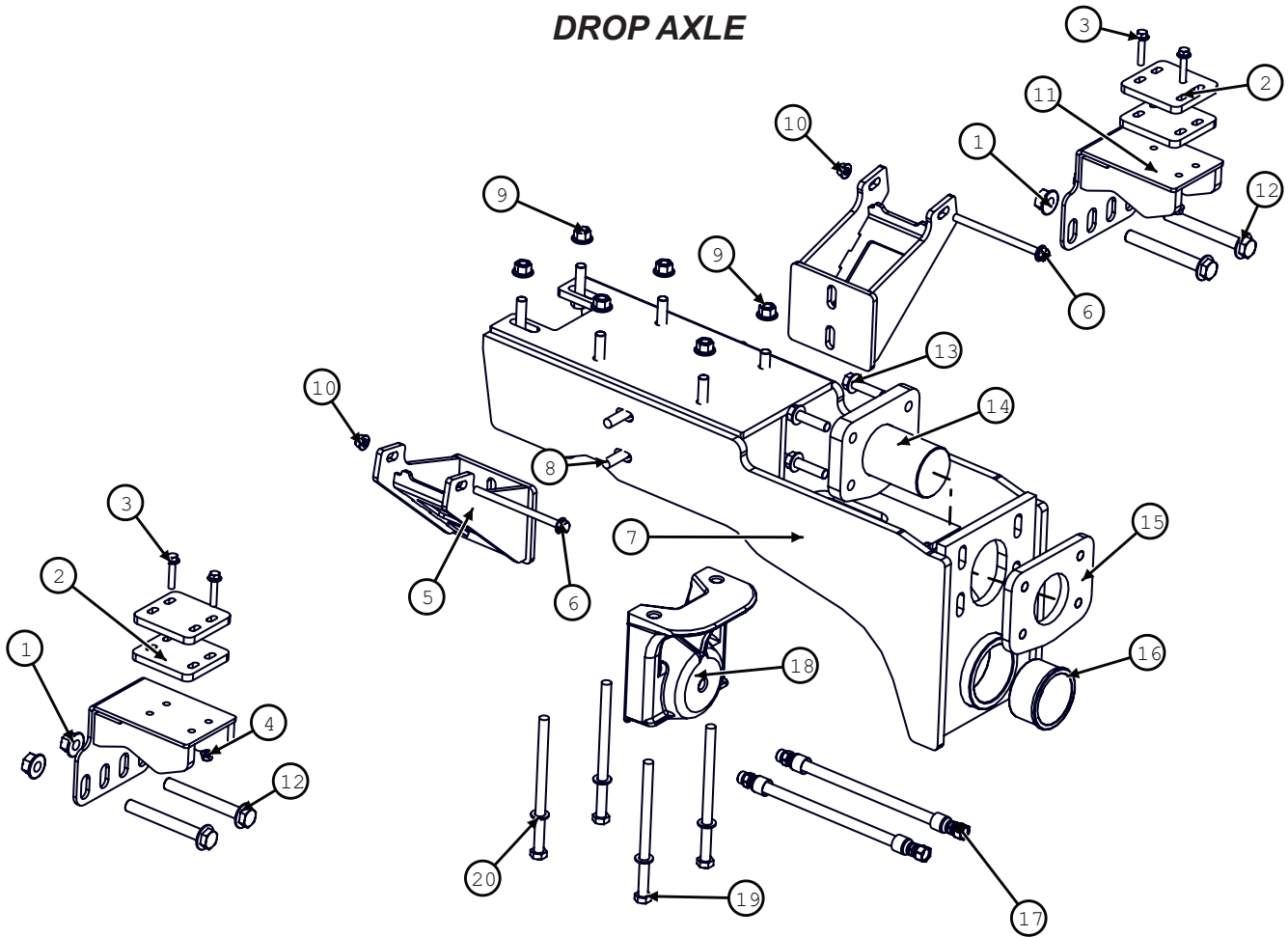

Drop Axle			
BOM ID	Part No.	Qty	Description
1	F-HNF-20ME	4	FLHN-10.9 M20X2.50
2	LP-299892	4	DA PLT, ROTATION STOP 16°
3	F-HCF-10M050E	4	SCREW, FLANGED HEX CAP
4	F-HNSF-10ME	4	FLHN-10.9 M10X1.5 STV
5	LW-299841	2	DA WLD, WING
6	F-HCF-12M180E	2	FLHC-10.9M12X2.0X180 (ONLY ON EARLY MY 13 COMBINES)
7	LW-291021	1	DROP AXLE SPACER
8	F-CB-16M050E	4	CARR-10.9M16X2.0X90
9	F-HNSF-16ME	10	FLHN-10.9M16X2.00 STV
10	F-HNFS-12ME	2	FLHN-10.9M12X1.75 STVR
11	LW-299792	2	DA WLD, ROTATION STOP
12	F-HCF-20M160E	4	FLHC-10.9 M20X2.5X160
13	F-HCF-16M060E	10	FLHC-10.9 M16 X 2.0 X 60
14	LW-291071	1	DA WLD, PIVOT
15	LP-291091	1	DA PLT, PVOT LOCK
16	LP-235092	1	LM BUSHING, DA PIVOT
17	LA-273461	2	HOSE, 3/8" R2 #8FF#8MF 15"
18	LM-299801	1	DA STAND-OFF, REAR AXLE
19	F-HC-16M250E	4	M16X2.0X250 HEX HEAD SCREW
20	F-FW-10	4	WASHER, FLAT, 5/8

Model JH9010 Hillco Leveling System
For Serial Numbers JH9010-13001 thru JH9010-13999

Hydraulic Components

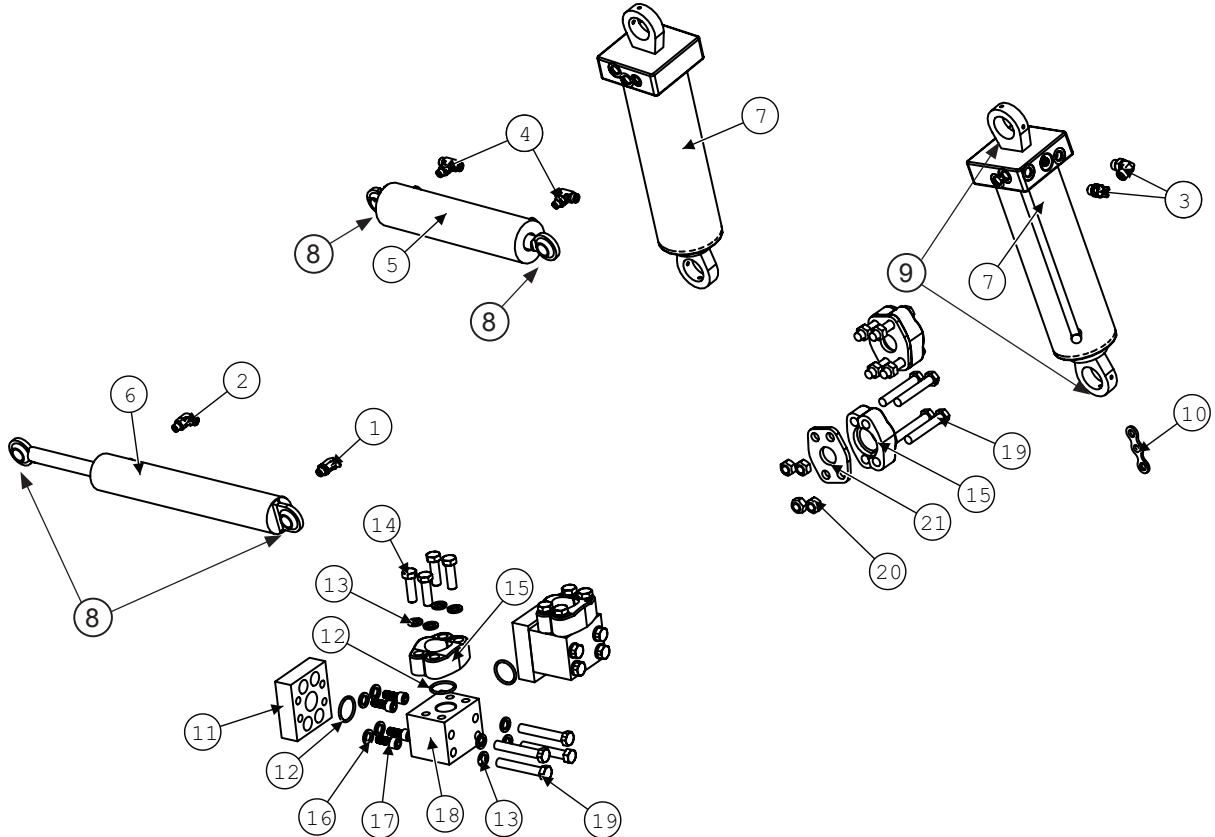

Hydraulic Components			
BOM ID	Part No.	Qty	Description
1	HA-F-6MF6MO	2	#6 MORS X #6 MORB 45 DEG
2	HA-L-6MF6MO	2	ELBOW, 90°, 6MF x 6MO
3	HA-L-8MF8MO	3	ELBOW, 90°, #8MORS#8MORB
4	HA-Q-06MF06MO	5	TEE, STRAIGHT THREAD, BRANCH -6MF x -6MO
5	HC-140342	2	MASTER CYLINDER, 3"B, 8-3/4"S,1-3/8"R, 17-1/4"CPC, CROSS
NS	HC-134201	-	SEAL KIT, MASTER CYLINDER
6	HC-147491	4	SLAVE CYLINDER, 2-1/2 B, 1-1/8" R, 12-1/2" S, 21" CPC
NS	HC-138581	-	SEAL KIT, SLAVE CYLINDER
7	HC-151002	2	LEVELING CYLINDER, 4-1/2"B,11"S,2"R, 22-1/2 CPC
NS	HC-135221	-	SEAL KIT, LEVELING CYLINDER
8	MC-150881	4	1" BEARING, SEALED SPHERICAL
9	MC-150881	4	1 3/8" BEARING, SEALED SPHERICAL
10	LP-274391	1	LM PLT, HYDRO HOSE SPACER
11	LM-272092	2	CODE 62 90° 1-1/4 ROTATIONAL ADAPTER
12	HC-147621	8	O-RING, CODE 62, 1-1/4"
13	F-LW-09	16	LW 9/16 HD
14	F-HC-14M045E	8	HC-10.9M14 X2.0X45
15	HC-147611	8	FLANGE, 1-1/4" CODE 62, HALF
16	F-LWHC-09	8	LW 9/16 HD HIGH COLLAR
17	F-SHC-14M030D	8	SHCS-12.9M14X2.0X30
18	LM-272082	2	HM BLOCK, CODE 62 1-1/4 90°
19	F-HC-14M090E	16	HC-10.9 M14X2.0X90
20	F-HNS-14ME	8	HN-10.9M14X2.0 STVR
21	LM-272161	2	HM PLT, CODE 62 1-1/4 UNION

Model JH9010 Hillco Leveling System
 For Serial Numbers JH9010-13001 thru JH9010-13999

Cross Port Relief

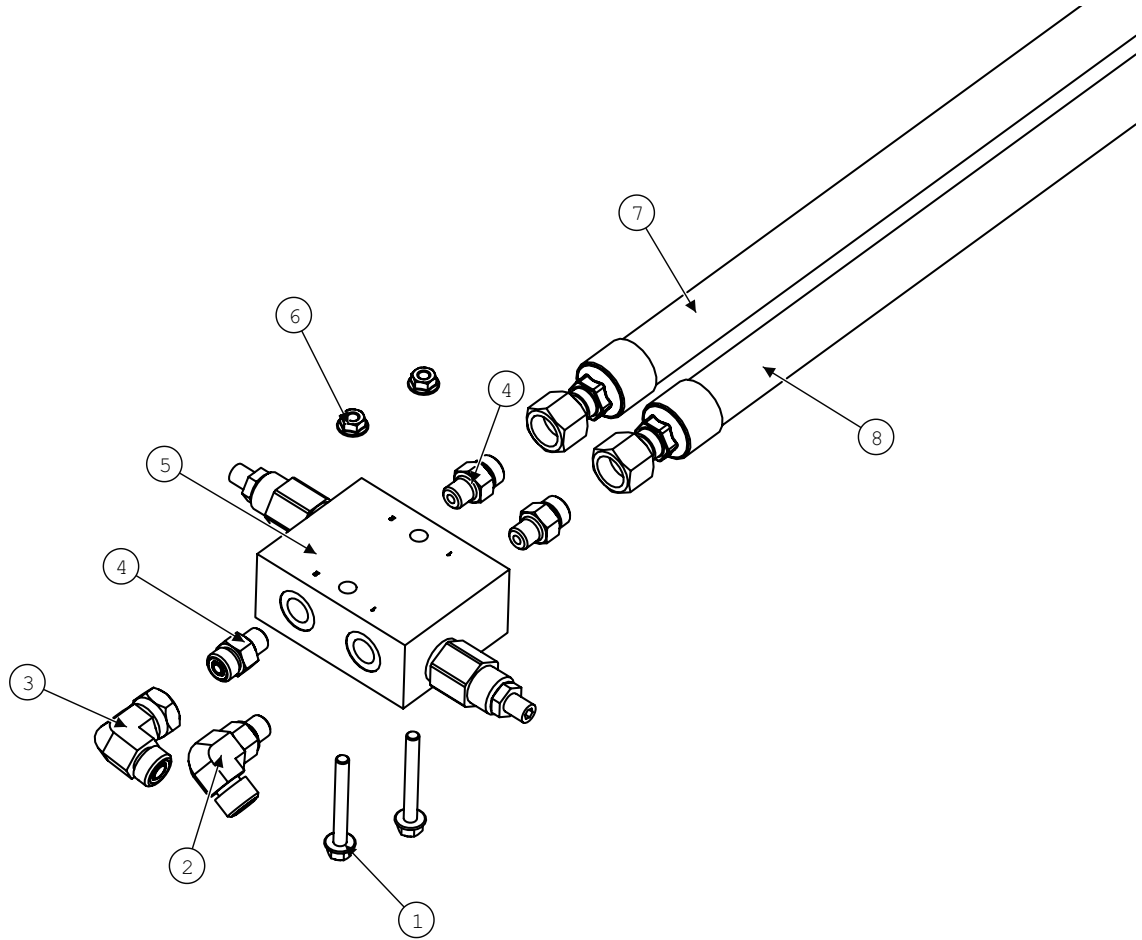

Cross Port Relief			
BOM ID	Part No.	Qty	Description
1	F-HCF-06M050E	2	FLHC-10.9 M6x1.0x50
6	F-HNF-06ME	2	FLHN-10.9M6X1.00
3	HA-L-06FF06MF	1	ELBOW, 90°, -6FF x -6MF
2	HA-L-6MF4MO	1	ELBOW, -6MORS X -4MORB
4	HA-S-6MF4MO	3	STR, -6MORS X -6MORB
5	HC-138691	1	MANIFOLD, RELIEF VALVE
7	LA-298441	1	100R2-06 X 46", -6FF STR x -6FF STR; Cross Port Relief to Base Port of Slave Cylinder
8	LA-298451	1	HOSE ASM, 100R2-06 35", -6FF STR x -6FF STR; Cross Port Relief to Rod Port of Slave Cylinder

Model JH9010 Hillco Leveling System
For Serial Numbers JH9010-13001 thru JH9010-13999

Dual Station Manifold

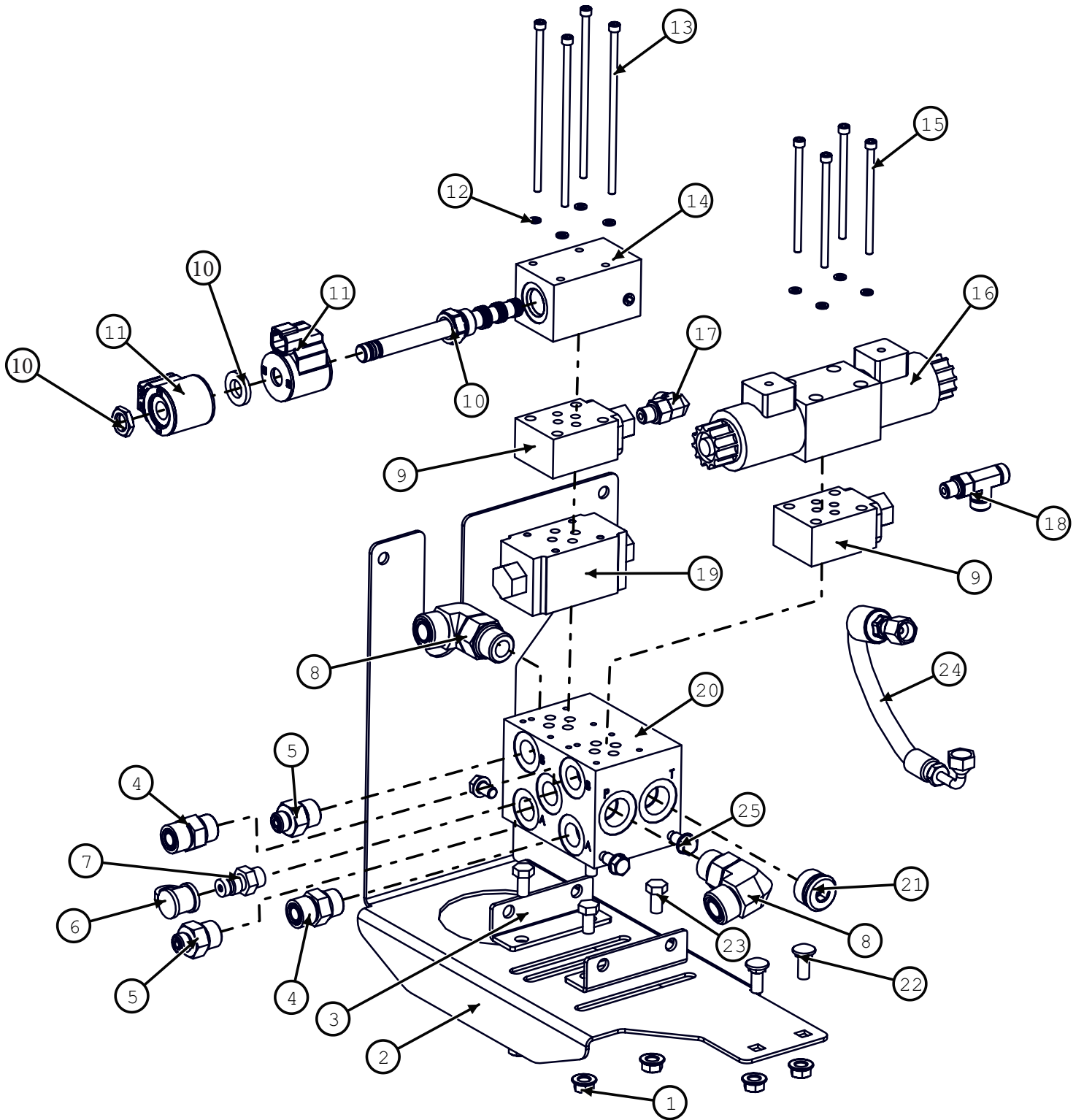

Model JH9010 Hillco Leveling System
For Serial Numbers JH9010-13001 thru JH9010-13999

Dual Station Manifold			
BOM ID	Part No.	Qty	Description
1	F-HNF-08ME	6	
2	LB-296131	1	HM PLT, MANIFOLD MNT
3	LP-267511	2	HM, PLT, MOUNT, MANIFOLD
4	HA-S-8MF8MO	2	STR, -8MF x -8MO
5	HA-S-4MF8MO	2	STR, -4 MF x -8 MO
6	HC-144001	1	COVER, DUST
7	HC-143991	1	COUPLER, QUICK-CONNECT HYD
8	HA-L-10MF10MO	2	ELBOW, 90°, -10MF x -10MO
9	HC-101264	2	VALVE ASM, LOAD SENSE SHUTTLE
10	HC-153671	1	CARTRIDGE, 4-WAY, 3-POS, MOTOR SPOOL (INCLUDES NUT AND SPACER)
11	HC-153681	2	COIL, FOR SP08-47 VALVES
12	F-LW-#10	8	WASHER, LOCK, SPLIT RING, #10
13	F-SHC-#10C80	4	SHC 10-24 X 5"
14	HC-153661	1	ADAPTER, D03 TO VC08-4 PORT
15	F-SHC-#10C52	4	SHC 10-24 X 3-1/4
16	HC-140411	1	VALVE, D03, PRO, CLY, (PRM2-063Z11/30-12)
17	HA-L-4MF4MO	1	ELBOW, 90°, -4MF x -4MO
18	HA-T-4MF4MO	1	TEE, RUN, 4MF x 4MO
19	HC-101034	1	CHECK VALVE, DUAL PILOT OPERATED
20	HC-138851	1	MANIFOLD, 2-STATION (DAMEN AD03P022S)
21	HA-E-10MO	2	PLUG, SOCKET HEAD, -10
22	F-CB-08M020F	2	CARR-8.8M8X1.25X20 HEAD SCREW
23	F-HC-8M016F	4	HC-8.8M8X1.25X.16
24	LA-300651	1	HOSE ASM 100R2-04 13", -4FF STR x -4FF 90°
25	F-HCF-05C08	4	FLHC 5/16-18 X 1/2 SERRATED

John Deere Header Lift Manifold Fittings

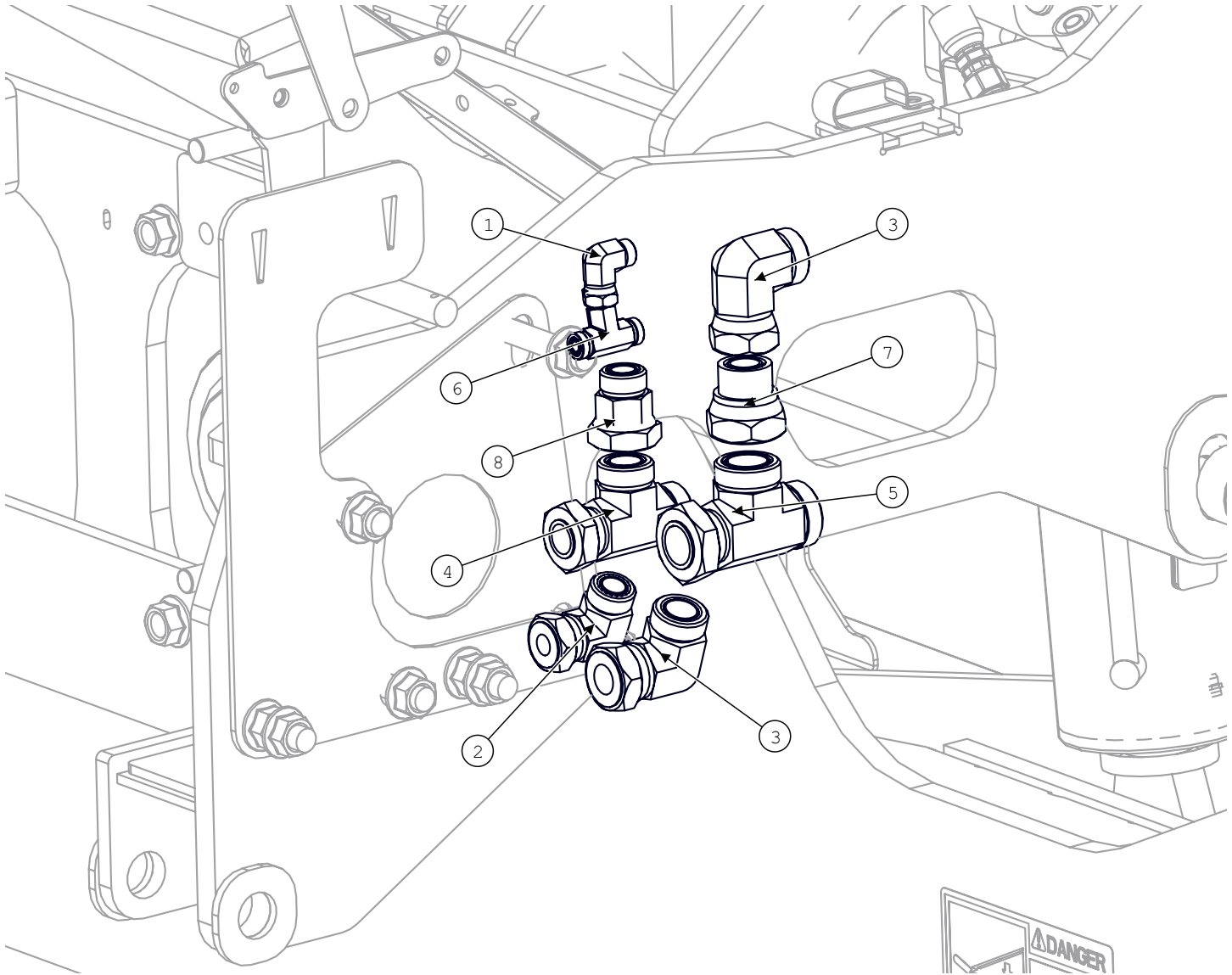

John Deere Header Lift Manifold Fittings			
BOM ID	Part No.	Qty	Description
1	HA-L-06FF06MF	1	ELBOW, 90°, -6FF x -6MF
2	HA-L-12MF12FF	1	ELBOW, 90°, -12MF x -12FF
3	HA-L-16FF16MF	2	ELBOW, 90°, -16MF x -16FF
4	HA-M-16FF16MF	1	TEE, SWIVEL NUT, RUN, #16
5	HA-M-20FF20MF	1	TEE, SWIVEL NUT, RUN, #20
6	HA-M-6FF6MF	1	TEE, SWIVEL NUT, RUN, -6FF x -6MF
7	HA-S-20FF16MF	1	STR, -20FF x -16MF
8	HA-S-16FF12MF	1	STR, 16FF x 12MF

Model JH9010 Hillco Leveling System
For Serial Numbers JH9010-13001 thru JH9010-13999

Hydraulic Hoses			
Part Number	Quantity	Description	Where Used
LA-273462	2	100R2-08 62", #10FF x #8FF 90°	Filter Head; Front and Side Ports to Valve Block Ports
LA-274141	1	100R15-20 124", 90° XR FLNG x STR FLNG	Extends Rear Hydrostat Line
LA-305181	1	100R15-20 121", 90° MR FLNG x STR FLNG	Extends Forward Hydrostat Line
LA-274162	1	100R2-06 32" #6FORS X #8FORS 90°	Replaces AH223259; Connect Proportionator Case Drain to Transmission
LA-276351	1	100R2-06 47" #8FORS #8FORS 90°	Extends Breather Line (Only on some models)
LA-295601	2	100R2-08, 103" 08FORSx08FORS	Leveling Hose from Manifold to Right Leveling Cylinder
LA-295601	2	100R2-06 X 195" -.06FF STR x -.06FF STR	Leveling Hose from Manifold to Left Leveling Cylinder
LA-297421	1	100R2-10 66", -10FF 90° x -10MF STR	Extends AH226084 to Proportionator Motor Supply
LA-297441	1	100R1-12 66", -12FF 90° x -12MF STR	Extends AH226085 to Proportionator Pump Supply
LA-297451	1	100R2-10 147", -10FF STR x -10FF 90°	Replaces AH219243; Connects Rear Filter Port to Proportionator Motor Return
LA-297481	1	100R2-06 31", -6FF 90° x -6MF STR	Extends AH226119 to the Transmission Lube
LA-297641	1	100R2-06 78", -06MF STR x -06FF 90°	Extends Right Brake Line
LA-297651	2	100R2-06 60", -06MF STR x -06FF STR	Extends Left Brake Line; Extends Lube Line
LA-297841	1	100R1-12 68", -16 90° x -10 STR	Leveling Manifold Return
LA-297851	1	100R2-10 72", -12 90° X -10 STR	Pressure to Leveling Manifold
LA-297862	1	100R2-04 80", -6 STR x -4 90°	Load Sense
LA-297922	1	100R16-12 91", -12FF 90° x -12FF STR	Relaces JD hose from Manifold to Bulkhead
LA-297932	2	100R16-12 44", -12FF STR x -12FF STR	Replaces the Left Header Pressure Hose
LA-298011	1	100R2-04 137", -4FF STR x -6FF STR	Header Trim to Master Cylinder Rod Port
LA-298021	1	100R2-04 126", -4FF STR x -6FF STR	Header Trim to Master Cylinder Base Port
LA-298291	1	100R1-16 36", -16MF x -16FF	Extends Pro-Drive Case Drain
LA-298321	1	100R16-12 42", -12FF STR x -12FF 90°	Replaces the Right Header Lift Hoses
LA-298331	1	100R17-16 90", -16FF STR x -16FF 90°	Replaces Header Lift Hose from Manifold to Bulkhead
LA-298441	1	100R2-06 X 46", -6FF STR x -6FF STR	Cross Port Relief to Base Port of Slave Cylinder
LA-298451	1	100R2-06 35", -6FF STR x -6FF STR	Cross Port Relief to Rod Port of Slave Cylinder
LA-299191	1	100R2-04,15",6FF90DEG	Extends JD Hose to Shift Block
LA-273461	2	3/8 100R2-06 15IN #8FORS X #8MORS	Extends Steer Lines

Model JH9010 Hillco Leveling System
For Serial Numbers JH9010-13001 thru JH9010-13999

RETRACTABLE LADDER

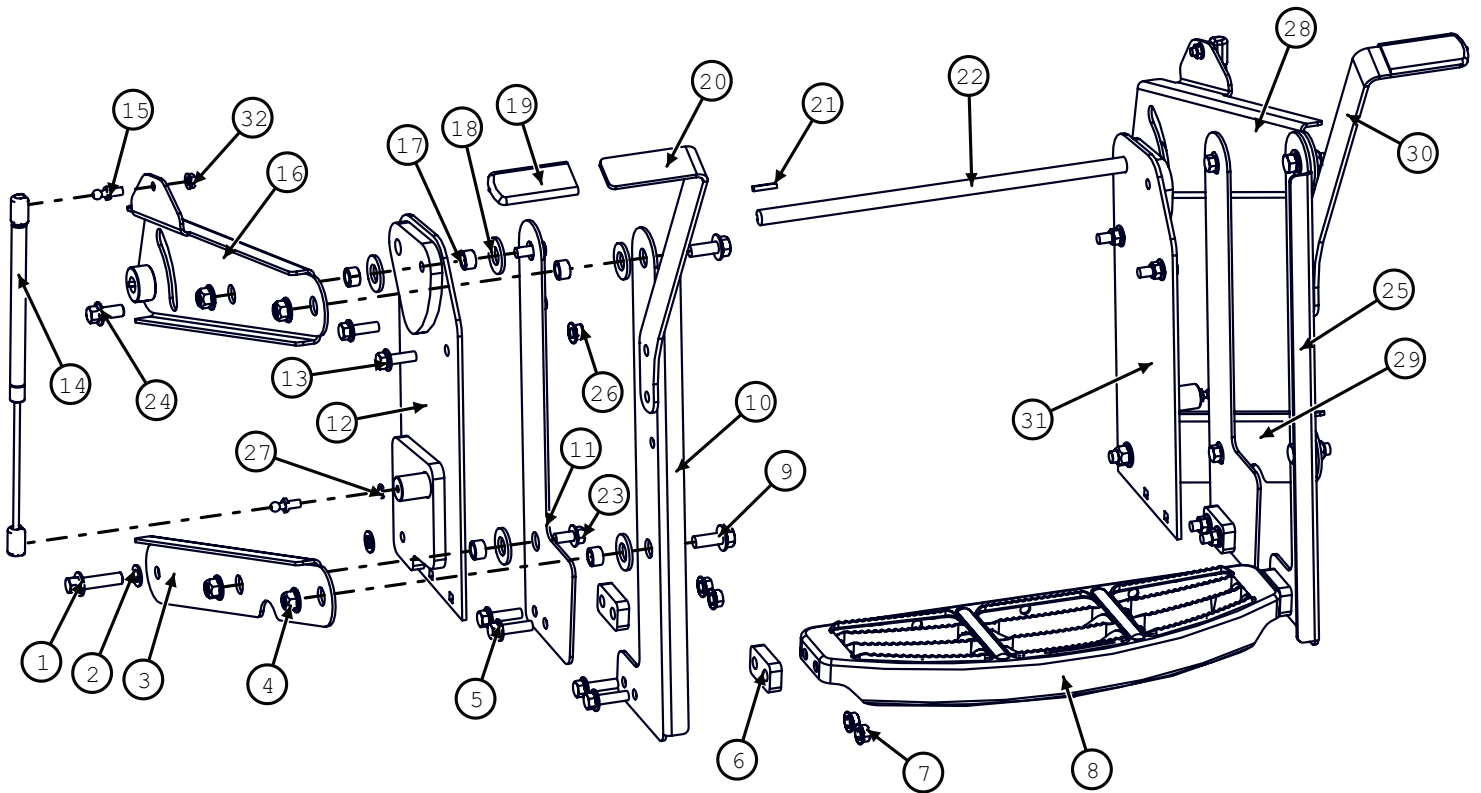

Model JH9010 Hillco Leveling System
For Serial Numbers JH9010-13001 thru JH9010-13999

Retractable Ladder

BOM ID	Part No.	Qty	Description
1-32	LA-300211	1	ASSEMBLY, MOVING STEP (HILLSIDE)
1	F-HCF-12M045E	2	FLHC-10.9M12X1.75X45
2	F-MB-14NR08	4	MACHINE BUSHING 14GA NR 1/2ID
3	LM-300091	1	LM LINK, LWR RIGHT PARALLEL
4	F-HNFS-12ME	10	FLHN-10.9M12X1.75 STVR
5	F-HCF-10M035E	8	SCREW, FLANGED HEX CAP, 10.9
6	LP-300191	4	LM SPACER, STEP
7	F-HNF-10ME	12	FLHN-10.9 M10 X 1.50
8	MC-152601	1	STEP, PLATFORM, STEP (HXE19816)
9	F-HCF-12M30E	4	FLHC-10.9 M12X1.75X30
10	LM-300161	1	LM PLT, VERTICAL OUTER RIGHT
11	LM-300111	2	LM LINK, VERTICAL INNER
12	LM-300061	1	LM WLD, RHT LADDER MNT
13	F-HCF-10M030E	4	FLHC 10.9 M10 X 1.5 X 30
14	MC-134921	2	STRUT, LIFT, 80LB, 9.5CPC, 15OPC
15	MC-134931	4	LIFT SUPPORT BRACKETS (PAIR)
16	LW-300121	1	LM WLD, TOP RIGHT LINK
17	LM-299181	10	LM BUSHING, LADDER PIVOT
18	F-MB-10WR12	10	MACHINE BUSHING 10GA WR 3/4ID
19	MC-151921	2	GRIP, JD#W25634
20	LB-306351	1	LM PLT, HANDLE, LEFT
21	F-KST-03X03X16	2	KEY, STR, 3/16 X 3/16 X 1
22	LM-298191	1	LM RND, ROCK SHAFT
23	F-HCF-10M020E	4	
24	F-HCF-12M025E	2	FLHC-10.9M12X1.75X25
25	LM-300171	1	LM PLT, VERTICAL OUTER LEFT
26	F-HNFS-10ME	4	FLHN-10.9M10X1.5 STVR
27	F-LW-05	2	LOCK WASHER 5/16"
28	LW-300141	1	LM WLD, TOP LEFT LINK
29	LM-300101	1	LM LINK, LWR LEFT PARALLEL
30	LB-300182	1	LM PLT, LADDER HANDLE
31	LM-300051	1	LM WLD, LEFT LADDER MNT
32	F-HNF-05C	2	FLHN 5/16-18

Ladder Wedge

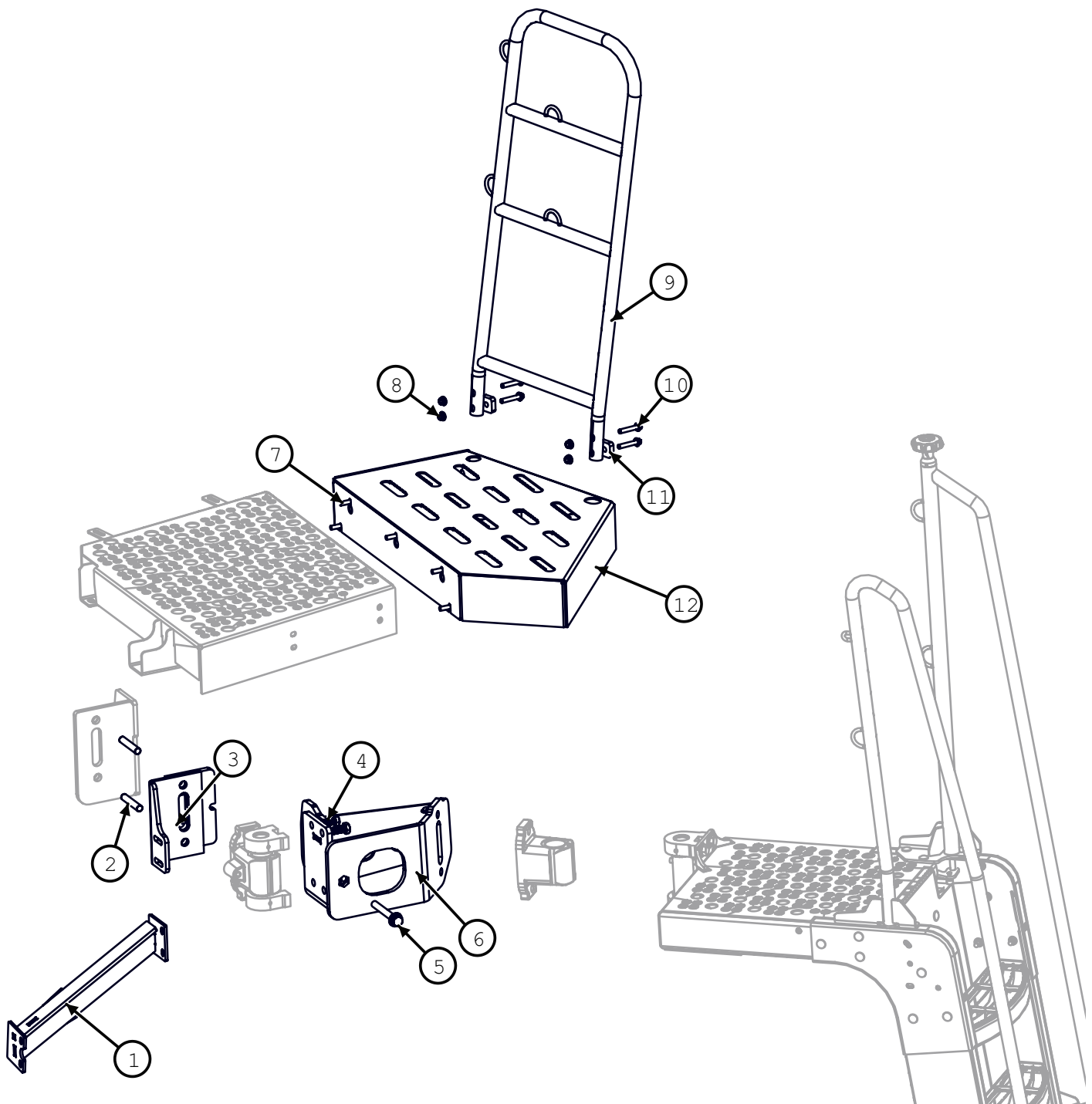

Model JH9010 Hillco Leveling System
For Serial Numbers JH9010-13001 thru JH9010-13999

Ladder Wedge

BOM ID	Part No.	Qty	Description
1	LW-296081	1	LM WLD, LADDER BRACE
2	F-STD-16M90E	2	STUD, DOUBLE-10.9 M16X2.00X90
3	LW-301181	1	LM ASM, SUPPORT BRACKET
4	F-HC-16M040E	4	HC 10.9M16X2.0X40
5	F-HCF-16M120E	1	
6	LW-300931	1	LM WLD, PIVOT EXTENSION
7	F-HCF-10M030E	5	FLHC 10.9 M10 X 1.5 X 30
8	F-HNF-10ME	4	FLHN-10.9 M10 X 1.50
9	MC-153571	1	HANDRAIL, EXTENSION ASSY FRONT (AXE16380)
10	F-HCF-10M060E	4	FLHC-10.9M10X1.50X060
11	LP-307281	2	LM PLT, SPACER, PLATFORM
12	LW-301102	1	LM WLD, PLATFORM

Controller/Wiring Harnesses

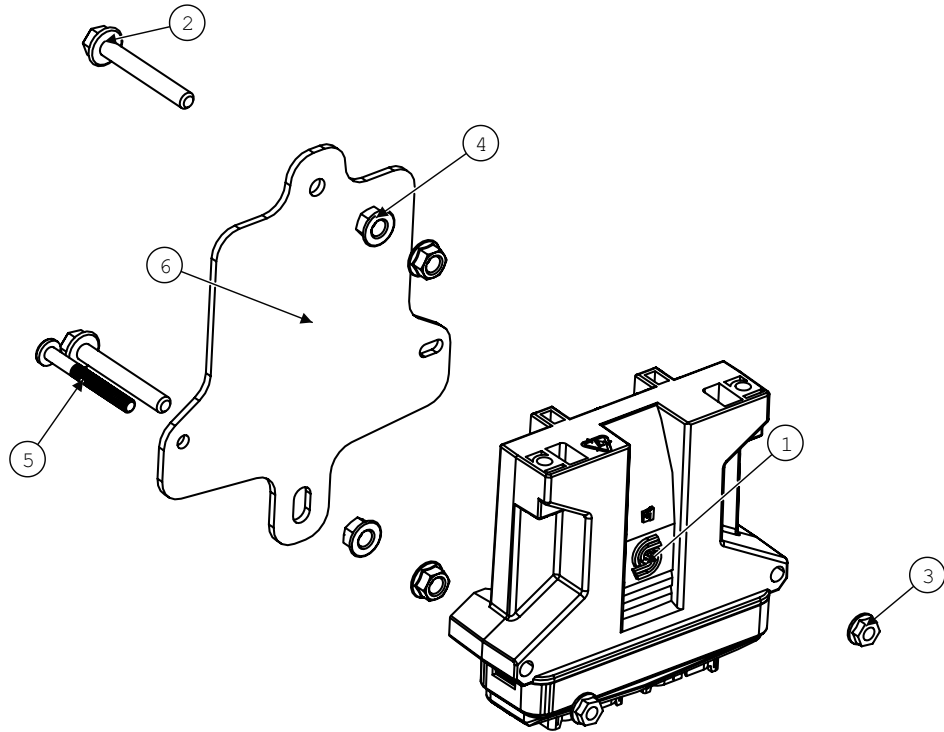

Electrical Components			
BOM ID	Part No.	Qty	Description
1-6	LA-297671	1	EM ASM, CONTROLLER W/MNT
1	EC-141831	1	SAUER-DANFOSS PLUS 1 CONTROLLER
2	F-HCF-08M060E	2	FLHC-M08X1.25X60
3	F-HNF-04F	2	FLHN-GR5 1/4-20
4	F-HNF-08ME	4	FLHN 10.9 M8 X 1.25
5	F-PHM-04C36	2	PHMS-GR5-1/4-20 X 2-1/4"
6	LP-295201	1	EM PLT, CONTROLLER MNT

Wiring Harnesses			
NS	Part No.	Qty	Description
NS	LA-294742	1	EM HARNESS, PRIMARY
NS	LA-294752	1	EM HARNESS, SECONDARY
NS	LA-294822	1	EM HARNESS, MANIFOLD (PFC)
NS	LA-295181	1	EM HARNESS, SENSOR PACKAGE
NS	LA-295342	1	EM HARNESS, TA SENSOR
NS	LA-296222	1	EM HARNESS, HEADER TRIM
NS	LA-296841	1	EM HARNESS, DUAL CAN LINK

Model JH9010 Hillco Leveling System
 For Serial Numbers JH9010-13001 thru JH9010-13999

Monitor

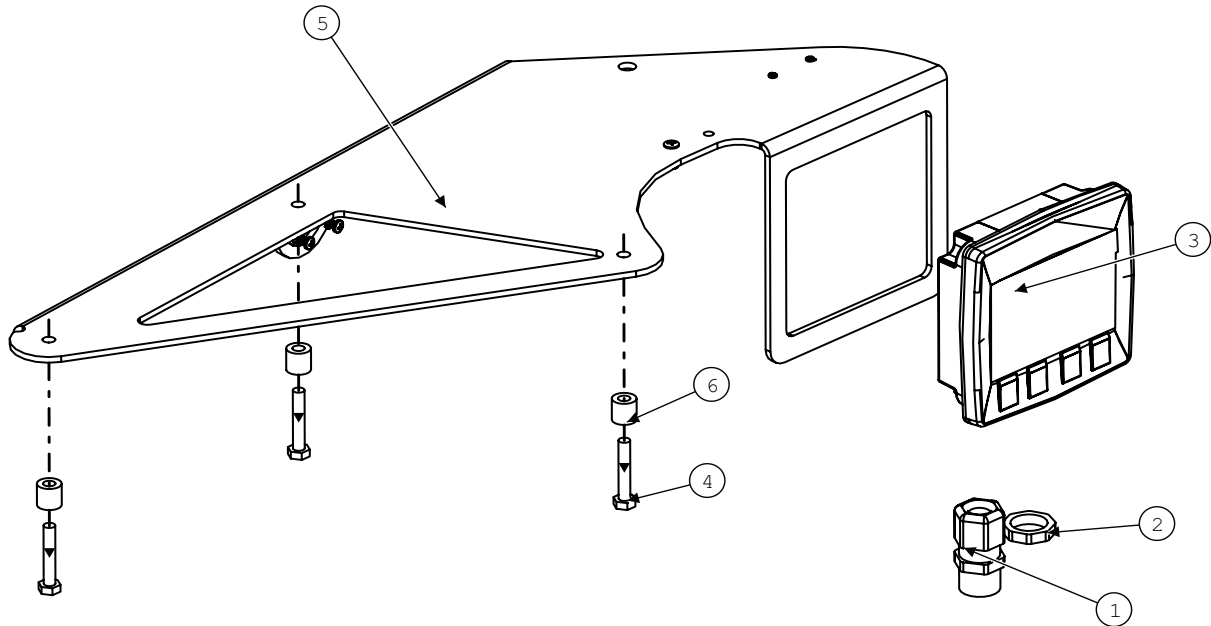

Electrical Components			
BOM ID	Part No.	Qty	Description
1	EC-138781	1	STRAIN RELIEF, NYLON, BLK,
2	EC-142121	1	STRAIN RELIEF NUT, 1/2" BLACK
3	EC-151591	1	DISPLAY, SAUER DANFOSS DP-250
4	F-HC-06M035E	3	HC-10.9 M6x1.0X35
5	LB-296702	1	EM MNT, HILLSIDE DISPLAY
6	MC-151931	3	BUSHING, NYLON .25ID x .50D

Decals and Literature



1) LL-133741



3) LL-153691

2) LL-151041

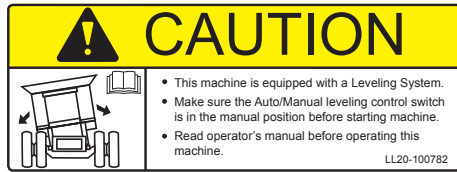

4) LL20-100782



6) LL20-100784



5) LL20-100783

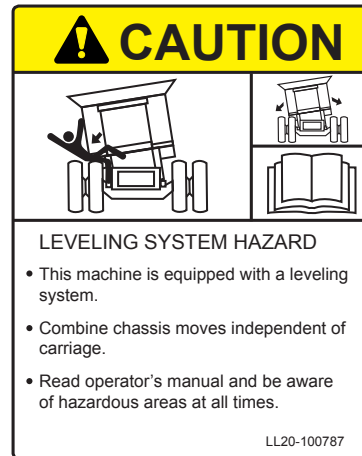

8) LL20-100787



7) LL20-100786



9) LL20-100788



10) LL-143621

Model JH9010 Hillco Leveling System
For Serial Numbers JH9010-13001 thru JH9010-13999

DECALS AND LITERATURE				
REF.	PART NO.	QTY.	PART NAME	DESCRIPTION
1	LL-133741	1	LABEL, GREASE 50 HRS	OC BULKHEAD
1	LL-133741	2	LABEL, GREASE 50 HRS	RIGHT & LEFT MAIN LEV CYL BOTTOM
1	LL-133741	1	LABEL, GREASE 50 HRS	MASTER CYLINDER ROD
2	LL-151041	2	DECAL, HILLSIDE LEVELING SYSTEM	SIDE OF COMBINE
3	LL-153691	2	DECAL, 20 YEAR ANIVERSARY	SIDE OF COMBINE
4	LL20-100782	1	CAUTION LEVELING SYSTEM CAB	WINDOW IN CAB
5	LL20-100783	2	DANGER, CRUSHING HAZARD	RIGHT & LEFT UNDERCARRIAGE
5	LL20-100783	2	DANGER, CRUSHING HAZARD	SIDES OF DROP AXLE ASSEMBLY
6	LL20-100784	2	DECAL, DANGER PINCH POINT	RIGHT & LEFT UPPER TRANS FACE PLT
7	LL20-100786	1	WARNING ELECTRICAL CRUSHING HAZARD	FRONT OF ELECTRICAL CONTROL BOX
8	LL20-100787	1	CAUTION - LEVELING SYSTEM HAZARD	ON LADDER PLATFORM
9	LL20-100788	1	DANGER - HYDRAULIC HAZARD	ON SIDE OF COMBINE ABOVE THE HYDRAULIC MANIFOLD
9	LL20-100788	2	DANGER - HYDRAULIC HAZARD	FOR EACH LEVELING CYLINDER
10	LL-143621	2	DANGER, AVOID CRUSHING INJURY	IN AREA NEAR SAFETY STOP STORAGE LOCATION
NS	LL-147651	1	LABEL, FEMA MEMBER TAG	NEAR SERIAL NUMBER TAG
NS	LA-255961	1	TAG, SERIAL NUMBER	
NS	LL-274401	1	LIMIT SWITCH WARNING LABEL	INSTALLED ON 1 LIMIT SWITCH
NS	EC-150131	1	DECAL, REMOTE SWITCH BOX	
NS	LL-289641	1	CM LABEL, MECHANICAL CYLINDER STOP	
NS	D-120613CMA01A	1	MANUAL, PARTS	
NS	D-120427MCA01B	1	MANUAL, OPERATORS	
NS	D-050611SLR01	1	WARRANTY REGISTRATION CARD	
NS	LL-239412	1	LABEL, STEERING WHEEL	TIED TO STEERING WHEEL DURING INSTALLATION
NS	D-120412CMA01	3	DEALER PDI & INSTALL CHECKLIST	

Model JH9010 Hillco Leveling System
For Serial Numbers JH9010-13001 thru JH9010-13999

Notes

Hillco Technologies, Inc.
107 1st Avenue
Nezperce, Idaho 83543

Phone	800-937-2461
	208-937-2461
Fax	208-937-2280

www.hillcotechnologies.com
email: support@hillcotechnologies.com