

Operator's Manual

(SN13001-13999)

Model JS5010, JS7010 & JS9010
Sidehill Leveling System
S550, S660, S670, S680 & S690

D-111124CMA01C
January, 2013

Contents

Model and Serial Number	1
Maximum Header Weights	1
Warranty Registration	2
Warranty Policy	3
Introduction	4
Safety	5
Signal Words	5
Operation Safety	6
Hydraulic Safety	6
Service and Maintenance Safety	7
Highway Operation and Transport Safety	7
Safety Labels	8
Product Description	12
Controls and Components	13
Leveling Control Switches	13
Hydraulic Gear Pump	13
JS9010 Hydraulic Flow	14
Leveling Control Manifold	14
Leveling Controller	14
Overcarriage Position Indicator	15
Slope Sensing Clinometer	15
Transition	15
Header Position Sensor	16
Feeder Chain and Slats	16
Feeder Drum Arms	16
Retractable Ladder Step	16
Mechanical Leveling Cylinder Stops	17
Carriage	17
Hydraulic Leveling Cylinders and Counter-Balance Valves	17
Leveling Cylinder Safety Stops	18
Drop Axle	19
Header Tilt Control Switches	20
Header Tilt System	20
Header Tilt Controls and Components	20
Operation	21
Ladder Position	21
Leveling System Controls	21
Lateral Header Tilt / Contour Master	22
Storage	22
Transporting Combine on a Trailer	22
Maintenance	23
Driveline Maintenance	24
100 Hour - Annual Maintenance	25
Adjustments	26
Rear Axle Spacing	26
Lateral Tilt Flow Control Adjustment	29
Transition Fore/Aft Adjustment Procedure	30
Lower Feeder Drum Stop Adjustment	30
Adjusting the Leveling Zero Point	31
Mechanical Leveling Cylinder Stops	32
Maximum Leveling Calibration	33
Header Tilt Setup	34
Header Tire Compatibility Chart	38
Decal Placement	41
Leveling System Specifications	43
Electrical Schematics	45
JS5010 Leveling Electrical Schematic	45
JS7010 Leveling Electrical Schematic	48
JS9010 Leveling Electrical Schematic	51
JS9010 Header Trim Schematic (Non Contour Master)	54
JS5010 & J79010 Header Trim Schematic (Non Contour Master)	55
Hydraulic Schematics	56
JS9010 Hydraulic (Leveling and Header Trim)	56
JS5010 & JS7010 Hydraulic (Leveling and Header Trim)	58
Notes	59

Model and Serial Number



Write the serial number and the model number of the leveling system and combine on the lines provided. It is important to reference these numbers when ordering parts or requesting technical support. We suggest that you give the leveling system serial number to your John Deere dealer to be kept with their combine serial number records.

Leveling System Model Number	JS5010	JS7010	JS9010	(circle one)
Leveling System Serial Number	-			
Combine Model Number				
Combine Serial Number				

Maximum Header Weights

JS9010	11,700 lbs
JS7010	11,700 lbs
JS5010	6,433 lbs

Hillco does not guarantee any non-John Deere header applications and will not be responsible for any damage incurred from improper header configurations.

Please call Hillco Technologies if you have any questions regarding the JS5010, JS7010 & JS9010 or any other header configuration.

Warranty Registration



HILLCO TECHNOLOGIES Warranty Registration

IMPORTANT!! This card must be **fully** completed and returned to Hillco Technologies within **thirty (30) days** of purchase by retail customer to validate the product warranty.

Customer Information:
Name: _____ Phone: (____) ____-____ Fax: (____) ____-____
Address: _____ City: _____ State: _____ Zip Code: _____

Hillco Product Information:
Product Purchased: _____ Date of Purchase: ____/____/____
Model #: _____ Serial #: _____

Combine & Header Information:
Combine: Brand: _____ Model #: _____ Serial #: _____
Header: (1) Brand: _____ Model #: _____ Width/Rows: _____
(2) Brand: _____ Model #: _____ Width/Rows: _____
(3) Brand: _____ Model #: _____ Width/Rows: _____

Dealer Information: Dealer Name: _____ City: _____ State: _____ Salesman (opt.): _____	Customer Signature: I certify that the above information is correct and I have received and read the Operator's Manual. Date: _____ Signature: _____
--	---

With the operator's manual packet is a green Warranty Registration card. Fill out this card and return it to Hillco Technologies.

Owner's Obligation

WARRANTY REGISTRATION- You must complete the Warranty Registration Card and submit it to Hillco Technologies, Inc. within thirty (30) days of the date of delivery to register the new equipment under Hillco's Warranty Policy.

Warranty Void if not Registered!

MAINTENANCE SERVICE- The operator's manual furnished to you with the equipment at the time of delivery contains important maintenance and service information. You should read the manual carefully and follow all maintenance and service recommendations. Doing so will result in greater satisfaction with your equipment and help to avoid service and warranty problems. Please remember that failures due to improper maintenance of your equipment are not covered by warranty.

Warranty Policy



Statement of Limited Warranty **(North American Harvest Products)**

Hillco Technologies, Inc. (Hillco) warrants its new products to be free from defects in material and workmanship for a period of twelve (12) consecutive months following the warranty start date.

The warranty start date for Hillco products invoiced by Hillco from October 1st through May 31st is the first day of June following the Hillco invoice date, or the first date of use, whichever is earliest. For Hillco products invoiced by Hillco from June 1st through September 30th the warranty start date is the date of invoice. Once the warranty period has begun, it cannot be stopped or interrupted.

Hillco's obligation under this warranty shall be limited to repairing or replacing, free of charge to the original purchaser, any part that, in Hillco's judgment, shows evidence of such defect. Hillco additionally agrees to repair, at no cost to the original purchaser, any physical damage to the product to which the Hillco product is directly attached provided that the damage is directly attributable to a defect in the design or manufacture of the Hillco product, as determined by Hillco, and that the damage occurs during the effective warranty period of the Hillco product.

Hillco warrants genuine Hillco replacement parts and components to be free from defects in material and workmanship for a period of ninety (90) consecutive days following the Hillco invoice date, or the remainder of the original equipment warranty period, whichever is longer.

Limitations to Warranty

This warranty does not cover:

- 1) Any product damaged by accident, abuse, misuse, negligence, or improper maintenance.
- 2) Any unauthorized product alteration or modification.
- 3) Any unauthorized repairs made with parts other than genuine Hillco parts unless specifically authorized by Hillco.
- 4) Any repairs performed by anyone other than Hillco or an authorized Hillco dealer unless specifically authorized by Hillco.
- 5) Any claims directly resulting from improper installation, except those installations performed by Hillco.

Warranty Procedure

A Hillco Warranty Registration Form must be fully completed and returned to Hillco within 30 days of sale of the product to the retail customer or the first day of use, whichever is earlier.

All warranty claims must be submitted on a fully completed Hillco Warranty Claim Form.

All warranty work must be performed, and claims submitted, within thirty (30) days of the occurrence of the claim and within the warranty period.

All parts removed during warranty repair should be held for a period of sixty (60) days after the warranty claim has been submitted to Hillco.

Hillco reserves the right to either inspect the product at the original retail purchaser's location, or the authorized Hillco dealer's location; or require it to be returned to Hillco, transportation charges prepaid, for inspection.

Limitation of Liability

Hillco makes no express warranties other than those, which are specifically described herein. Any description of the goods sold hereunder, including any reference to buyer's specifications and any descriptions in circulars and other media published by Hillco is for the sole purpose of identifying such goods and shall not create an express warranty that the goods shall conform to such description.

THIS WARRANTY IS EXPRESSLY IN LIEU OF ALL OTHER WARRANTIES EXPRESSED OR IMPLIED. There are no implied warranties of merchantability or fitness for a particular purpose. This warranty states Hillco's entire and exclusive liability and buyer's exclusive remedy for any claim for damages in connection with the sale or furnishing of Hillco products, their design, suitability for use, installation, operation, or for any claimed defects herein. **HILLCO WILL IN NO EVENT BE LIABLE FOR ANY INCIDENTAL OR CONSEQUENTIAL DAMAGES WHATSOEVER, NOR FOR ANY SUM IN EXCESS OF THE PRICE RECEIVED FOR THE GOODS FOR WHICH LIABILITY IS CLAIMED.**

No representative of Hillco nor any dealer associated with Hillco has the authority to change the items of this warranty in any manner whatsoever, and no assistance to purchaser by Hillco in the repair or operation of any Hillco product shall constitute a waiver of the conditions of this warranty, nor shall such assistance extend or revive it.

Hillco reserves the right to make improvements in design or changes in specifications at any time, without incurring any obligation to owners of units previously sold.

D-041201LJH01

Introduction

Thank you for choosing the Hillco Technologies' Sidehill Leveling System to compliment your farming operation. This product has been designed and manufactured to meet the needs of farmers wanting to increase the performance of John Deere S Series combines.

Safe, efficient and trouble free use of your Sidehill Leveling System requires that you, and anyone else who will be operating or maintaining the leveling system, read and understand the safety, operation, and maintenance information contained in the Operator's Manual.

If extra copies of the operator's manual are needed, contact Hillco at 1-800-937-2461 or download it from Hillco Technologies' website at www.hillcotechnologies.com



Keep this manual handy for frequent reference and to pass on to new operators or owners. Call your Hillco dealer or Hillco if you need assistance or information at 1-800-937-2461.

OPERATOR ORIENTATION – The directions left, right, front, and rear, as mentioned throughout this manual, are as seen from the combine operator's seat and facing in the direction of forward travel.

SAFETY ALERT SYMBOL



This Safety Alert symbol means
ATTENTION! BECOME ALERT! YOUR SAFETY IS INVOLVED!

The Safety Alert symbol identifies important safety messages on the Hillco Leveling System and in the manual. When you see this symbol, be alert to the possibility of personal injury or death. Follow the instructions in the safety message.

Signal Words

Note the use of the signal words DANGER, WARNING, and CAUTION with the safety messages. The appropriate signal word for each message has been selected using the following guidelines:

DANGER - An immediate and specific hazard, which WILL result in severe personal injury or death if the proper precautions are not taken.

WARNING - A specific hazard or unsafe practice, which COULD result in severe personal injury or death if proper precautions are not taken.

CAUTION - Unsafe practices which COULD result in personal injury if proper practices are not taken, or as a reminder of good safety practices.

Operation Safety

1. Read and understand the Operator's Manual and all safety labels before operating the leveling system.
2. Make sure that all controls are in the manual position before starting the combine.
3. Clear the area of all bystanders, especially children, before starting the leveling system and during operation.
4. Make sure all safety shields are in place before operating the combine. Never operate the machine with the shields removed.
5. Keep hands, feet, hair and clothing away from all moving and/or rotating parts.
6. Stay seated in the cab during operation.
7. Operate controls only when sitting in the seat of the combine.
8. To avoid engine damage, do not run the machine for extended periods of time when it is in the leveled over position.
9. Always travel at a safe speed. Use caution when making turns or traversing ditches.
10. The leveling system is equipped with a maximum level warning lamp. This lamp indicates when the machine has reached its maximum leveling capability. There are restrictions as to tread width and tire selection for combines used in harvesting slopes greater than the maximum leveling capability of the leveling system.
11. The use of after-market grain tank extensions is prohibited from use on combines equipped with Hillco Leveling Systems.
12. Level Limit Stops should be used on combines that rely on the limit switches to stop the leveling prematurely to prevent sheet metal damage.

Hydraulic Safety

1. Do not search for high-pressure hydraulic leaks without hand and face protection. A tiny, almost invisible leak can penetrate skin, thereby requiring immediate medical attention.
2. Use cardboard or wood to detect leaks – never your hands!
3. Before inspecting the hydraulic system of the leveling system, install the safety stops.
4. Before operating the leveling system, ensure that there are no obstructions between the chassis and the carriage.
5. Maintain proper hydraulic fluid levels.
6. Ensure all fittings and hoses are in good repair.
7. Do not make any repairs to the leveling system hydraulic system including: valves, hydraulic hoses, adapters, pumps, manifolds, or reservoirs without first contacting your authorized Hillco dealer.



Service and Maintenance Safety

1. Review the Operator's Manual and all safety items before servicing or maintaining the leveling system.
2. Place the Auto/Manual leveling switch in the "Manual" position, stop the combine engine, wait for any moving parts to stop, block the tires, the header, and the cylinder areas before servicing, repairing, adjusting, or maintaining the leveling system.
3. Hydraulic oil is under pressure. Use caution when dealing with the hydraulic system.
4. Keep hands, feet, clothing and hair away from all moving and/or rotating parts.
5. Clear the area of bystanders, especially children, when carrying out any maintenance, repairs or making any adjustments.

Highway Operation and Transport Safety

1. Check with local authorities regarding combine transport on public roads. Obey all applicable regulations and laws.
2. Check clearance, elevations and widths of combine for travel near power lines, bridges, trees, etc.
3. Make sure the Auto/Manual leveling toggle switch is in the "Manual" position for all transport and highway travel situations.
4. Always travel at a safe speed. Use caution when making corners or meeting traffic.

Safety Labels

Familiarize yourself with the location of all safety labels. Read them carefully to understand the safe operation of your machine.

READ OPERATOR'S MANUAL SYMBOL

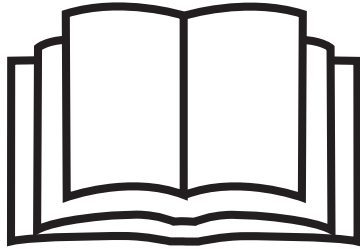

Decals, which display the Read Operator's Manual symbol, are intended to direct the operator to the Operator's Manual for further information regarding maintenance, adjustments and/or procedures for particular areas of the Leveling System. When a decal displays this symbol refer to the Operator's Manual for further instructions.

TO APPLY NEW OR REPLACEMENT LABELS

1. Make sure the label area is smooth by removing any debris such as dirt or old labels.
2. Wash the area with soap and water and then dry it thoroughly.
3. After the area has completely dried, peel the backing off the safety label and place it onto the cleaned area.
4. Make sure all areas of the label have adhered to the machine by pressing down on the entire face of the label, including the corners.

! DANGER



HYDRAULIC HAZARD

- Loss of hydraulic pressure may cause combine to tip.
- Read operator's manual before disconnecting any hydraulic components.

LL20-100788



! DANGER



AVOID CRUSHING INJURY
Install safety stops on the main leveling cylinders before performing repair or maintenance on the leveling system to prevent accidental tipping of combine chassis.



LL-143621

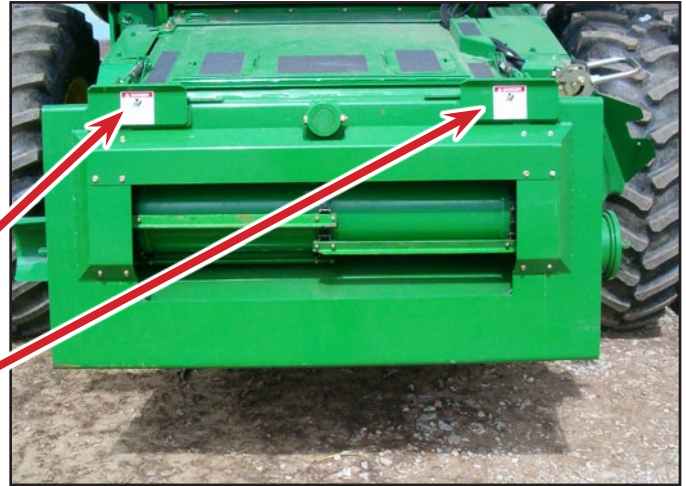

! DANGER



PINCH POINT HAZARD

- Keep hands, feet and body away from moving parts.
- Do not stand or climb on machine when operating.
- Hazard occurs during leveling and header trim.

LL20-100784

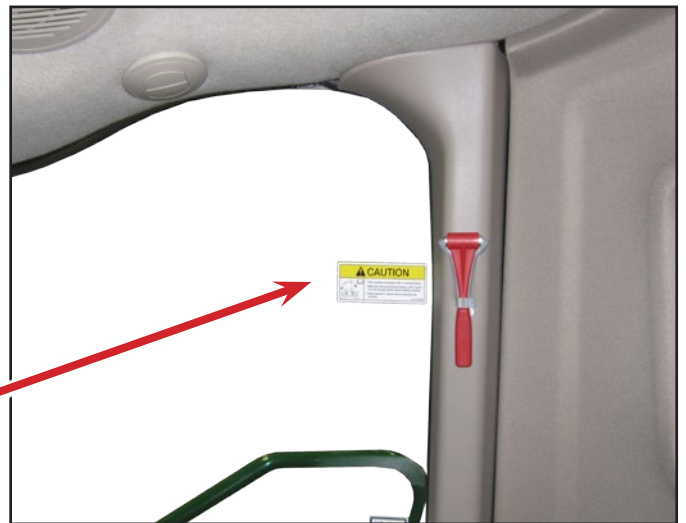

! CAUTION



- This machine is equipped with a Leveling System.
- Make sure the Auto/Manual leveling control switch is in the manual position before starting machine.
- Read operator's manual before operating this machine.

LL20-100782

! DANGER



CRUSHING HAZARD
To prevent serious injury or death:

- Keep all persons and objects clear while any part of this machine is in motion.

LL20-100783



! CAUTION



MOVING STEP HAZARD
Bottom step lowers and retracts upward.
Use caution when using ladder.

LL20-100785



! CAUTION

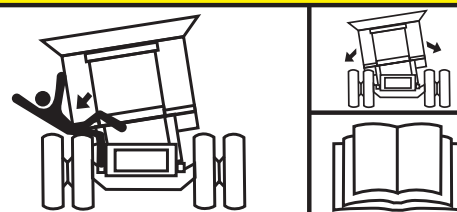

LEVELING SYSTEM HAZARD

- This machine is equipped with a leveling system.
- Combine chassis moves independent of carriage.
- Read operator's manual and be aware of hazardous areas at all times.

LL20-100787

! DANGER



HYDRAULIC HAZARD

- Loss of hydraulic pressure may cause combine to tip.
- Read operator's manual before disconnecting any hydraulic components.

LL20-100788



! DANGER





AVOID CRUSHING INJURY
Install safety stops on the main leveling cylinders before performing repair or maintenance on the leveling system to prevent accidental tipping of combine chassis.

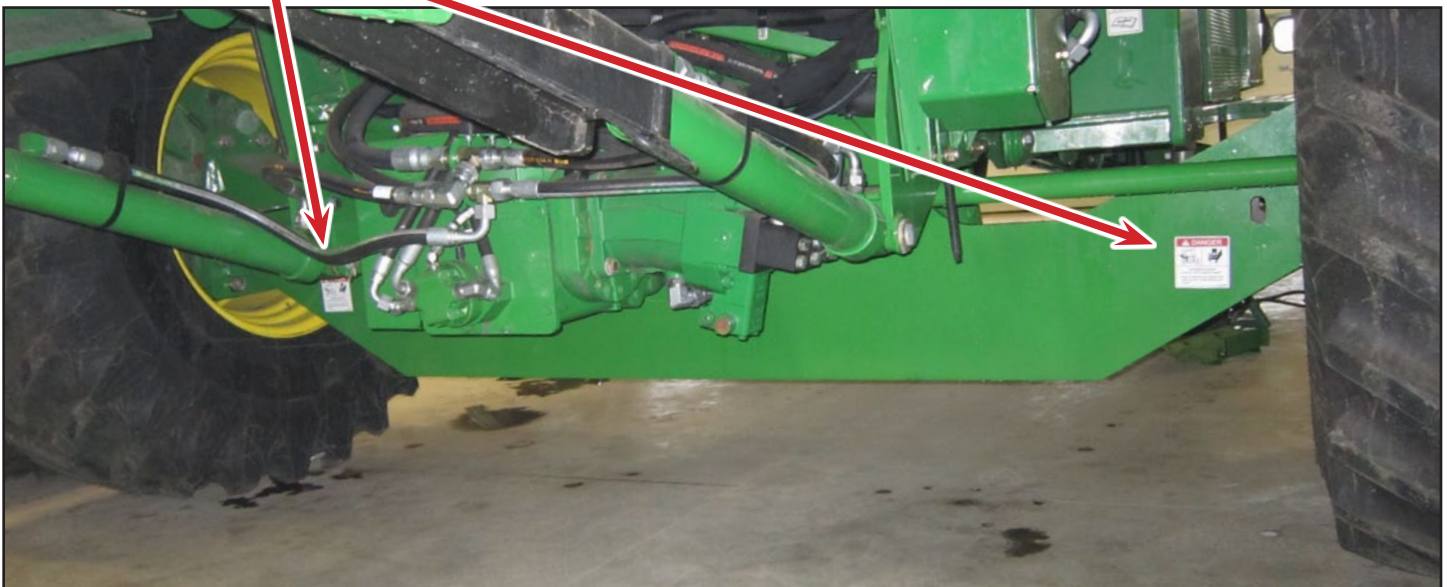

LL-143621

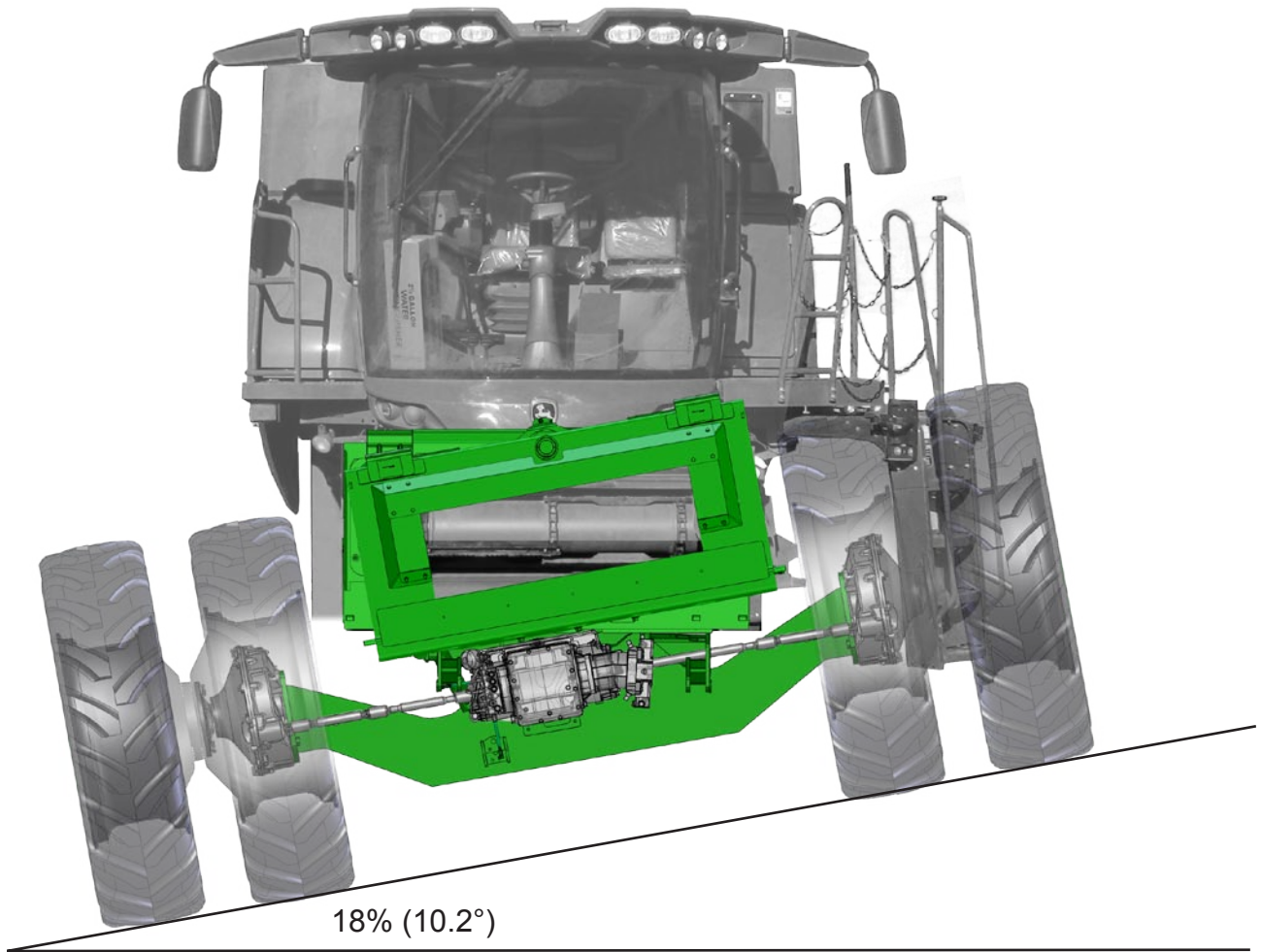

Product Description



The Hillco Sidehill Leveling System is designed for John Deere S Series combines. Hillco designed the Sidehill Leveling System to maintain the combine's threshing capacity and harvesting efficiency on contours of slopes up to 18%. This leveling system is designed to be installed with little modification to the combine.

The Sidehill Leveling System tilts the combine's chassis laterally, automatically compensating for slopes up to 18% as it moves across sloping terrain. The threshing platform remains level and allows both the combine and the operator to perform at maximum efficiency.

The leveling system uses a clinometer to sense the combine's chassis position in relation to "level". As the combine moves onto a slope, the chassis leans out of level and the clinometer senses the deviation and sends a signal the controller. The controller opens the appropriate leveling valve. The leveling valve allows hydraulic oil to flow into the leveling cylinder. The cylinders tilt the combine's chassis to correct for the tilt, bringing the chassis back to level.

As the combine's chassis levels, the master header tilt cylinder pushes hydraulic oil to the header tilt cylinder, which counter-rotates the header to keep it parallel to the ground. The operator can manually adjust the header's position or, alternately, may use the combine's original lateral tilt electronics and sensor-equipped header to automatically compensate for varying ground contours.

Controls and Components

Leveling Control Switches

The leveling control switches (A) are located on the far side of the CommandTouch Armrest Console.

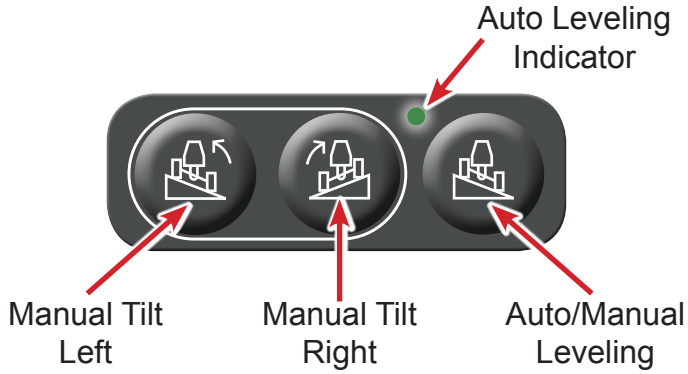

A - Auto/Manual Leveling

Auto/Manual Leveling — The Auto/Manual leveling button is used to toggle between the Automatic and Manual Modes. In Manual Mode the chassis will not rotate until initiated by the operator. In Automatic Mode, rotation of the chassis is initiated by the controller as dictated by changes in the slope. The operator can momentarily override the controller using the Manual Left and Right Buttons. The combine will return to level once the button is released.

Manual Tilt Left and Manual Tilt Right — These buttons allow the operator to rotate the chassis to the left or right as desired.

JS5010 & JS7010 Only

Hydraulic Gear Pump

The JS5010 and JS7010 have a Hydraulic Gear Pump (B) that is mounted directly to the output shaft of the combine's rear engine housing. It provides the necessary hydraulic flow to operate the leveling systems functions. The gear pump isolates the leveling system's hydraulic flow from the remaining combine's hydraulics.

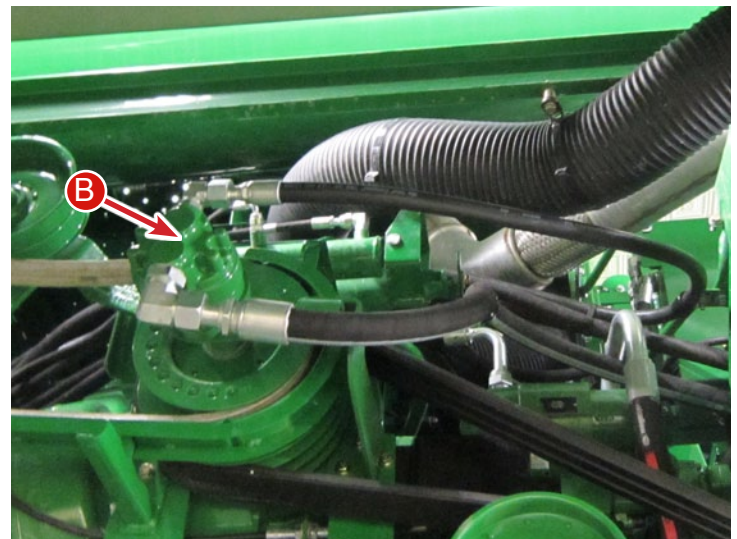

B - Gear Pump

JS9010 Hydraulic Flow

Hydraulic flow for the JS9010 leveling system is supplied from the “T” located in the Deere pressure supply line on the header height valve block (A). This valve is located on the left side of the combine below the cab. From this “T” oil flows to the Hillco leveling valve located behind the inspection door on the operator’s platform. Oil is returned from the leveling valve to a “T” located in the John Deere header height valve block.

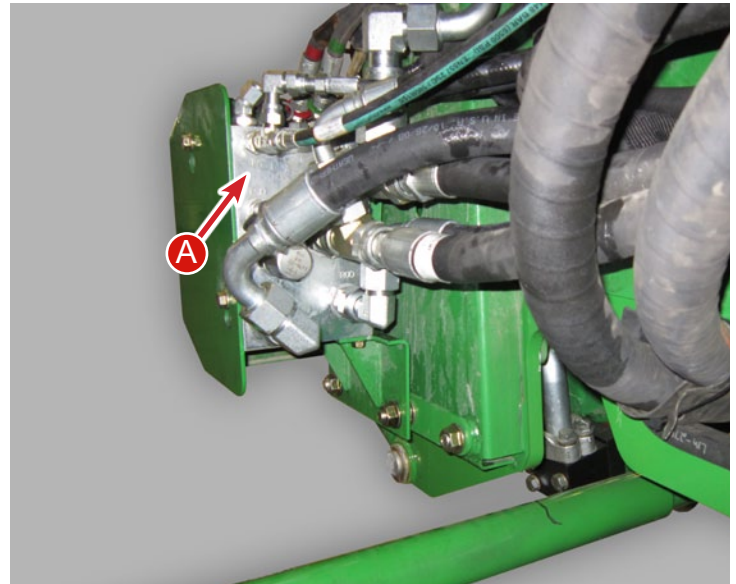

A - Header Height Valve Block

Leveling Control Manifold

The leveling control manifold (B) is located behind the inspection door on the operator’s platform. The operator electronically activates the manifold by either pushing the manual leveling buttons or having it in automatic mode. The manifold diverts hydraulic flow to the corresponding leveling cylinder to rotate the chassis.

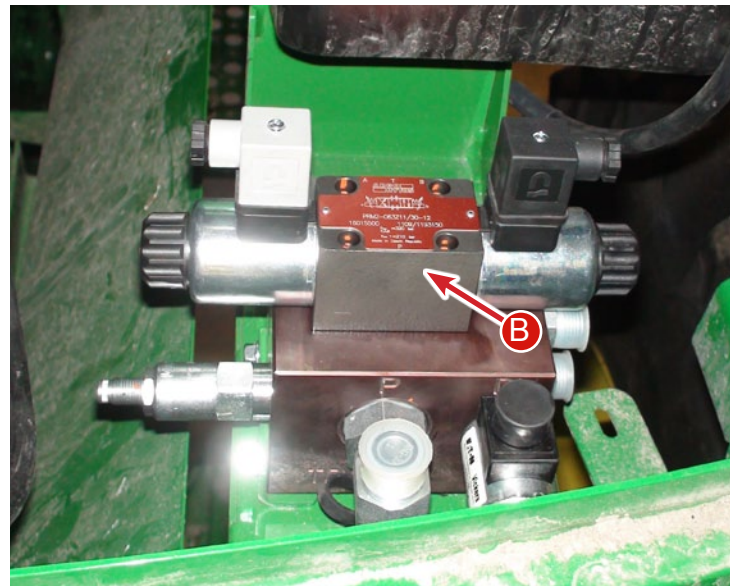

B - Leveling Manifold

Leveling Controller

The electronic leveling controller (C) is located behind the inspection door on the operator’s platform above the leveling manifold. The controller processes slope information and outputs signals to the hydraulic leveling valve. When auto leveling is activated the leveling controller levels the chassis up to a maximum slope of 18%.



C - Leveling Controller

Overcarriage Position Indicator

Attached to the overcarriage and undercarriage is the position indicator (A). The position indicator outputs a signal to the controller of the overcarriage position relative to the undercarriage. This also acts as a maximum level indicator. When the combine is nearing maximum level the controller reduces the amps to the leveling valve decreasing the hydraulic flow. This provides for smooth leveling when achieving maximum level.



A - Undercarriage Position Indicator

Slope Sensing Clinometer

Located on the overcarriage near the Overcarriage Position Indicator is the Slope Sensing Clinometer (B). This clinometer outputs a signal to the controller. This output is a value that tells the controller the chassis' position relative to level.

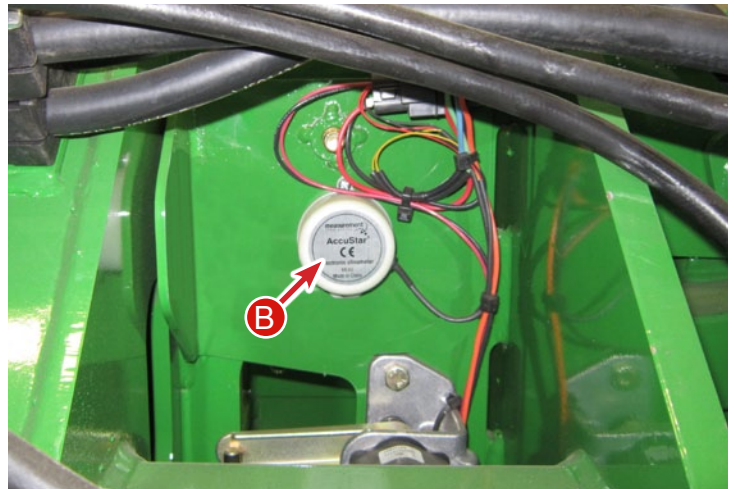

B - Slope Sensing Clinometer

Transition

The transition is added to the front of the feeder house to pivot the header and allow it to follow the contour of the ground. The transition will rotate 22% or 12.5° both directions.



C - Transition

Header Position Sensor

Located on the right side of the transition is the header position indicator (A). It utilizes a linkage between the face plate and the transition to indicate the header position relative to the combine. The position is then displayed in the corner post of the cab.

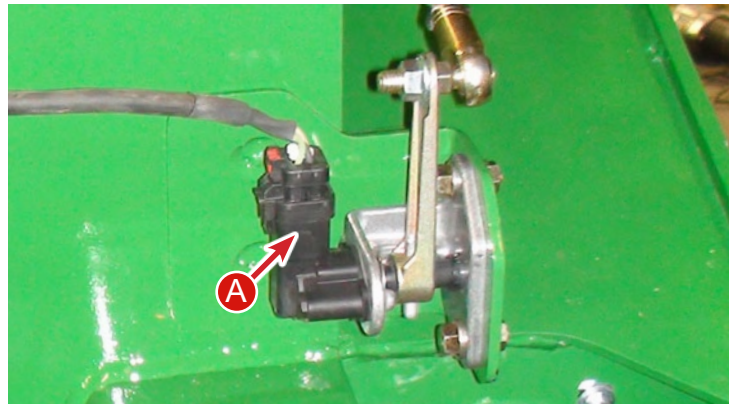

A - Transition Position Indicator

Feeder Chain and Slats

The feeder chain is extended and slats are added to accommodate the increased feeder house length.

Specifications

Acorn Nut on Feeder Chain	40N*m/30lb-ft
Chain Slat Hardware	40N*m/30lb-ft

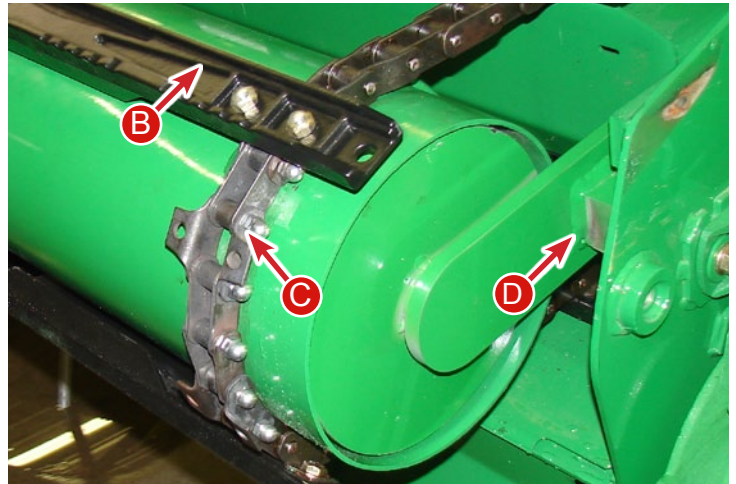

B - Slat
C - Acorn Nut
D - Drum Arm

Feeder Drum Arms

Hillco provides longer feeder drum arms that accommodate the increased length of the feeder house.

Retractable Ladder Step

All sidehill combines are equipped with a retractable bottom step.

If the ladder does not extend and retract properly check the fasteners in all of the pivot locations and make sure they are not over tightened. Over tightening of these fasteners will cause the ladder to bind. Make sure that the gas-charged struts keep the ladder fully retracted. Replace the struts if they appear to be weak. If the ladder does not fully retract, permanent damage may occur during field operation.



CAUTION!

It is recommended that combines with 800/65R32, 480/80R42, or 520/85R38 drive tires not have the bottom rubber step due to the possibility of ground contact.

Mechanical Leveling Cylinder Stops

Some tire configurations may come into contact with the side panel when the combine is leveled over. Limit settings will prevent this contact, however, Hillco requires installing mechanical leveling cylinder stops. This will prevent damage in the event of hydraulic or electrical failure. To set the stops level the combine over both directions until there is 1" between the tire and the closest contact point. Add cylinder stops to prevent the cylinder from over-leveling the combine. Contact Hillco for these cylinder stops.

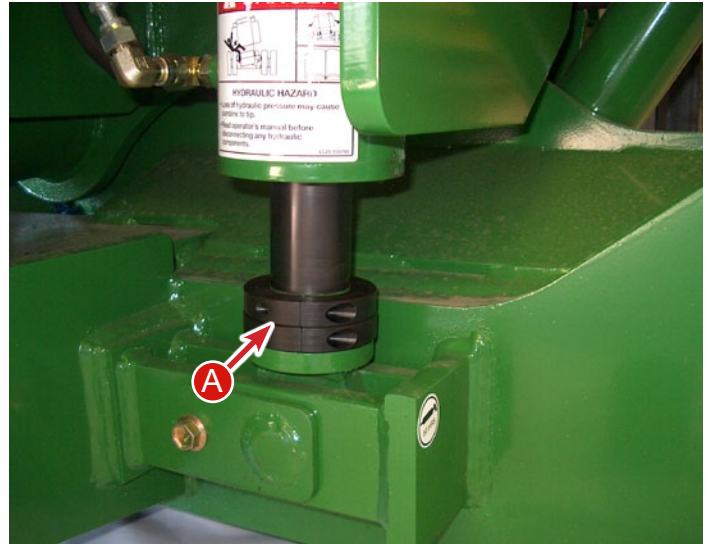

A - Mechanical Leveling Cylinder Stops
5/8 inch - Part # MC-137251
1/8 inch - Part # MC-137501

Carriage

The carriage is designed to support the combine's chassis while allowing the combine to rotate through full range of motion. It consists of an undercarriage and an overcarriage. The drive wheels, final drives, and transmission are mounted to the undercarriage. The overcarriage bolts to combine's axle and chassis. The leveling cylinders connect to the overcarriage and the undercarriage. The carriage raises the combine chassis seven inches to prevent the tires from coming into contact with the side panels.

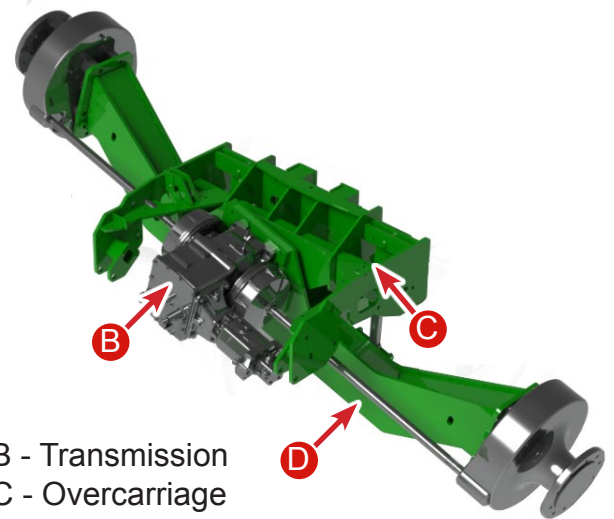

B - Transmission
C - Overcarriage
D - Undercarriage
E - Counter-Balance Valve
F - Leveling Cylinders

Hydraulic Leveling Cylinders and Counter-Balance Valves

JS7010 & JS9010

There are two leveling cylinders located on the rearward side of the leveling system's carriage. These cylinders are pressurized by the leveling hydraulic valve to tilt the combine chassis to correct for slope changes. Both leveling cylinders are equipped with built in hydraulic counter-balance valves that positively lock the oil into the cylinders until a pressure signal is sent from the hydraulic leveling valve. These counter-balance valves lock the chassis position in the event of hydraulic hose failure. The counter-balance valves can be adjusted if needed.

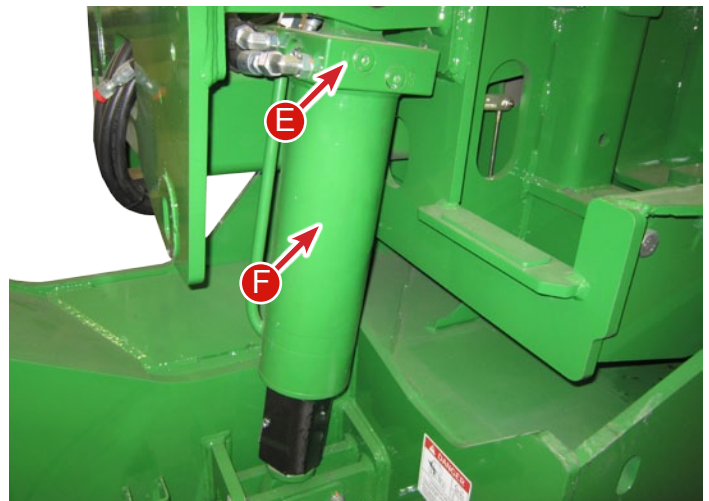

JS7010 & JS9010 Only

JS5010

There are two leveling cylinders located on the rearward side of the leveling system's carriage. These cylinders are pressurized by the leveling hydraulic valve to tilt the combine chassis to correct for slope changes. Both leveling cylinders are equipped with an external hydraulic counter-balance valves (A) that positively lock the oil into the cylinders until a pressure signal is sent from the hydraulic leveling valve. These counter-balance valves lock the chassis position in the event of hydraulic hose failure. The counter-balance valves can be adjusted if needed.

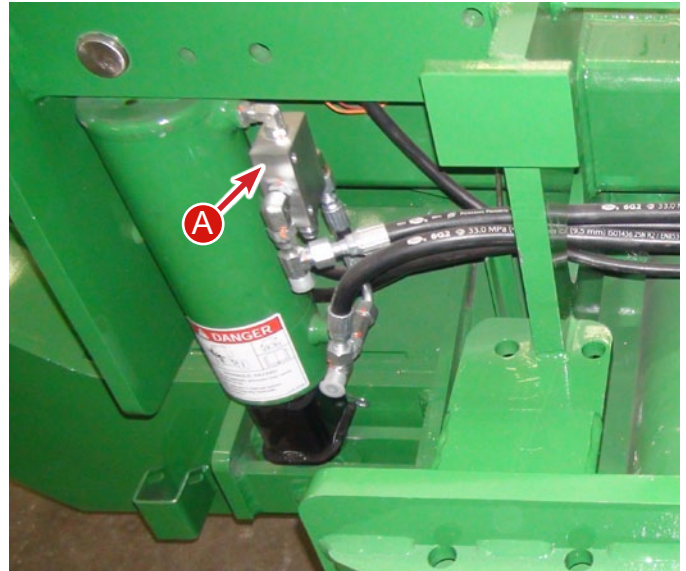

A - Counter Balance Valve

Leveling Cylinder Safety Stops

When the leveling cylinder safety stops are installed on the leveling cylinders, the carriage cannot rotate. The stops must be installed before working on or around the leveling system and when hauling the combine. It is recommended that the stops be inserted during long-term storage. When the stops are not being used, they should be stored on the mount next to the leveling cylinder.

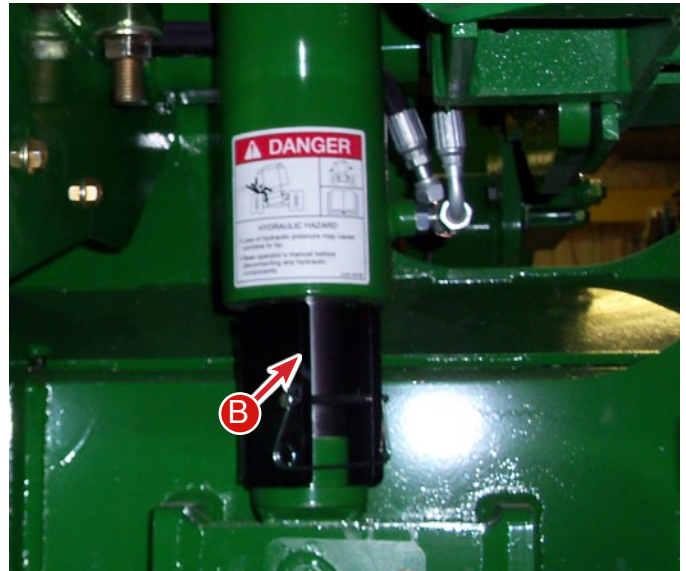

B - Cylinder Safety Stops
C - Cylinder Safety Stop Holder

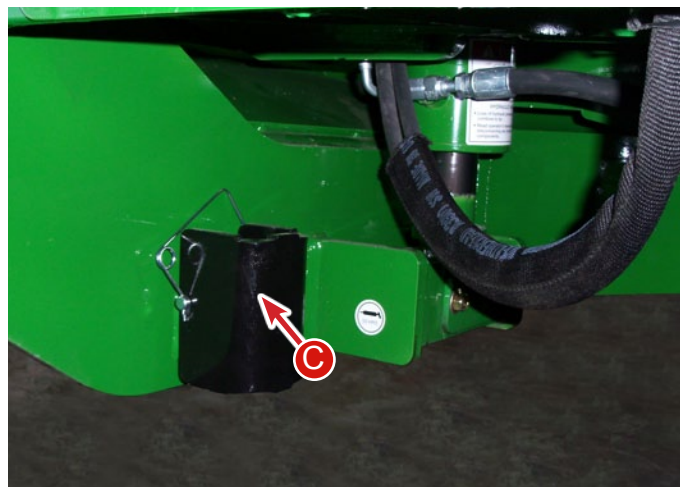



WARNING!

Install the cylinder stops before working on or around the leveling system. Failure to install the cylinder stops before working on or around the leveling system may result in sudden chassis rotation.

Drop Axle

The drop axle (A) raises the rear of chassis to match the height change due to the leveling carriage. The drop axle allows the rear axle to match the carriage's range of motion.

Drop axle wings (B) are installed for additional stability between the drop axle and the chassis.

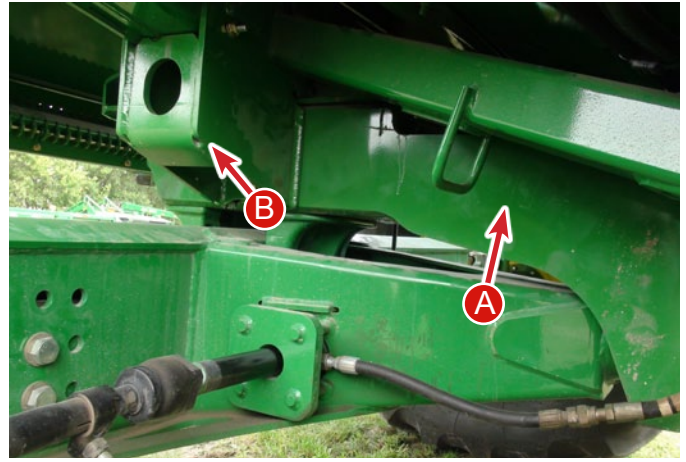

A - Drop Axle
B - Drop Axle Wing



IMPORTANT!

Because of the increased rotation of the rear axle it is necessary to space the rear wheels out to avoid interference with shields. See the Rear Axle Spacing Chart for more information.

Header Tilt Controls and Components

Header Tilt Control Switches

The manual header tilt switch is located in the hydro handle and is used to manually control the header tilt angle. Consult your John Deere Operator's Manual for explanation of the Contour Master operation.



A - Header Trim Switch
B - Master Cylinder

Header Tilt System

The header tilt hydraulic system consists of the header tilt control valve, master cylinder, slave cylinder, flow control, and relief valve. As the combine levels, the carriage extends or retracts the master cylinder, which sends oil to the slave cylinder. The slave cylinder counter-rotates the header. No electronic function is required for this action to occur.

The operator can manually trim the header angle with the header trim switch on the hydro control handle. In the Contour Master mode, the header angle is automatically trimmed by activating the lateral tilt valve, which is coupled to the master/slave circuit. In case the header contacts the ground, a relief valve prevents damage to the header and feeder house.

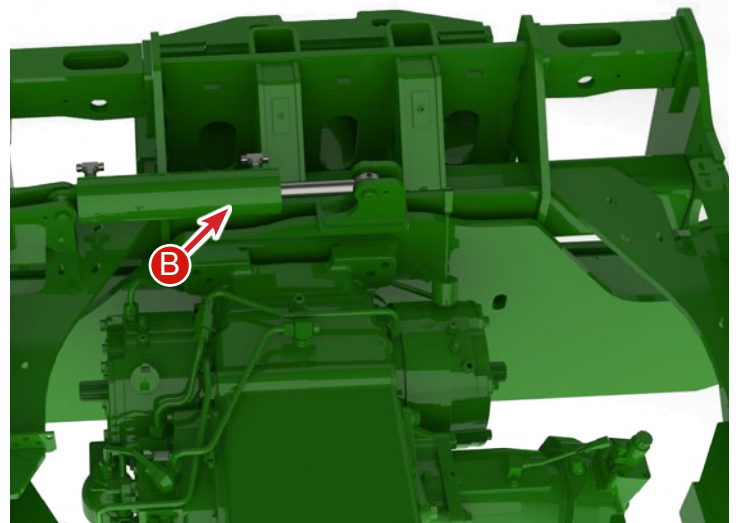

C - Slave Cylinder

Operation



CAUTION!

Before operating the leveling system, ensure that the leveling cylinder safety stops are not installed on the leveling cylinder. Operating the system with the safety stops installed may cause damage to the carriage, leveling cylinders, or stops.

Ladder Position

Operating the leveler with the ladder in the 90° will damage the ladder. To provide increased operator access, Hillco has provided an alternative ladder position and installed a ladder stop. The ladder stop prevents the ladder from rotating into the extended or 90° position.

Leveling System Controls

AUTOMATIC MODE: Pushing the Auto/Manual Leveling Button (A) will toggle between Auto & Manual. The green light shows when the leveling system is in Auto Leveling Mode.

The automatic leveling controller monitors changes in slope and corrects chassis position to maintain a level chassis position. The Manual Tilt Left/Manual Tilt Right Leveling Buttons will override the automatic leveling controller while the switch is being pressed. Upon release of the switch, the leveling system will return to automatic leveling mode and search for level.

MANUAL MODE: Pushing the Auto/Manual Leveling Button will toggle between Auto & Manual. If the green light is not lit it is in Manual Mode. In Manual mode the Manual Tilt Left/Manual Tilt Right leveling switch will level the combine left and right. When the switch is released the combine chassis will maintain the current chassis position.



CAUTION!

Do not operate the leveling system with the ladder in the extended or 90° position otherwise ladder damage may result.



A - Auto/Manual Leveling

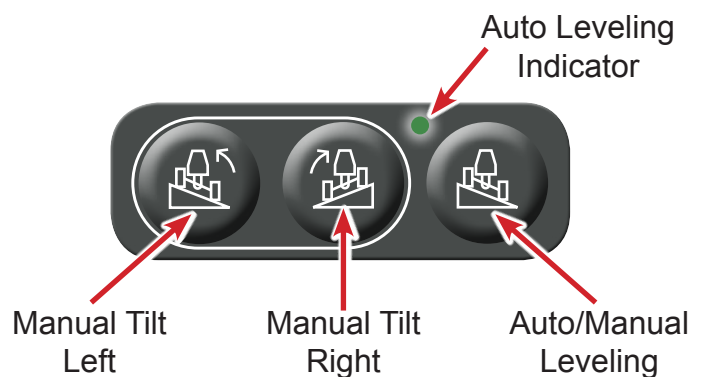

CAUTION!

Do not unload grain from the combine while operating the Leveling System in Automatic Mode. The chassis may tilt unexpectedly and cause damage to the unloading auger.

Lateral Header Tilt / Contour Master

To tilt the header manually, depress the header tilt switch (A) on the left for tilt left, or on the right side for tilt right. The Hillco leveling system is fully compatible with John Deere's Contour Master lateral tilt electronics. To run the Contour Master functions refer to your combine operator's manual.



A - Lateral Header Tilt

Storage

When storing the combine between seasons, Hillco strongly recommends that the leveling cylinder safety stops are installed on the leveling cylinders. This will ensure that the combine does not settle during storage.



CAUTION!

Before driving the combine into a building, ensure that the leveling system is in the road transport mode. This will ensure that the combine does not unexpectedly level. Unexpectedly leveling may cause damage to the building or the combine.

Transporting Combine on a Trailer

Before loading the combine, switch the leveling system into manual mode and install the cylinder stops. This will ensure that there are not any unexpected weight shifts during the loading process. In addition to the Tie Down locations on the combine, Hillco provides T-hook slots (B) on the undercarriage for securing combine to the trailer.

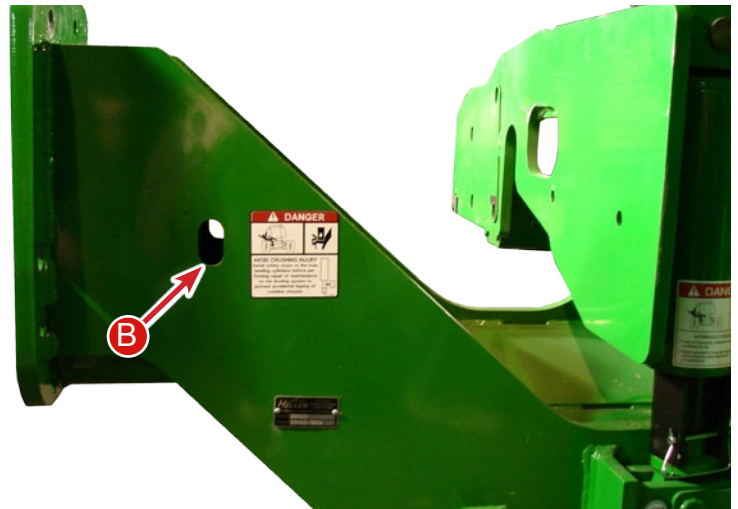

Maintenance

Recommended Grease: NLGI Multi Purpose Grease

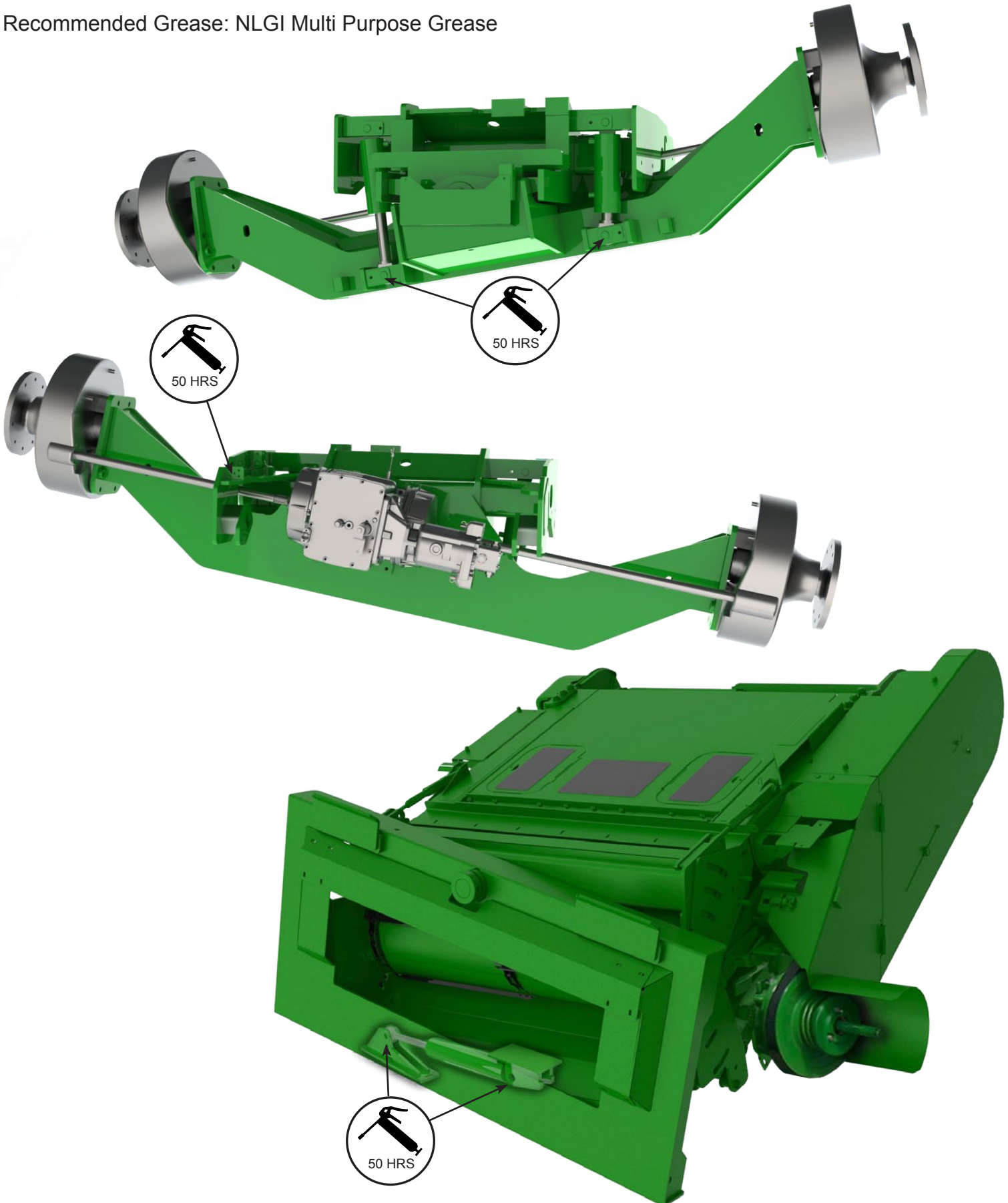

The Transition Pivot Pin and the Rear Drop Axle Spacer utilize Graphite Micarta Bushings that do not require grease.

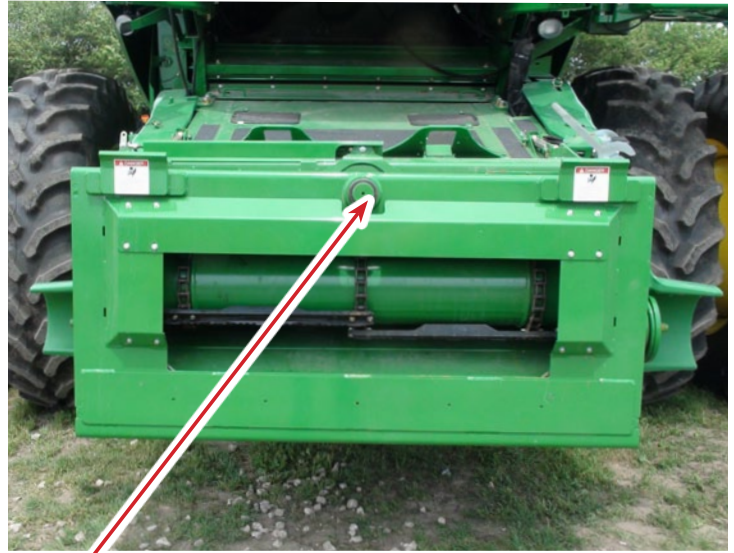

Graphite Micarta Bushings



Driveline Maintenance

Standard PTO Style Drive Shafts - These drive shafts utilize a single cross at each end of the drive shafts. Grease zerks on both crosses and the zerk on the outer profile tube (at the slip joint) should be greased on 50-hour intervals.

Constant Velocity Drive Shafts - These drive shafts utilize two universal joints and a ball-and-socket joint at each end of the drive shaft. There are a total of 7 grease zerks per drive shaft and they must be greased on 8-hour intervals and more frequent in severe duty applications.



WARNING!

It is important that headers equipped CV drivelines be greased at the appropriate intervals to prevent damage. Warranty will not cover drivelines not properly maintained.



100 Hour - Annual Maintenance

Inspect the following areas:

REAR AXLE

- All bolts are properly tightened (combine to spacer 235lb-ft and spacer to rear axle are 153 lb-ft)
- Torque rear wheel bolts (150lb-ft + ¼ turn w/RWA, 232lb-ft w/o RWA)
- Steering hoses are properly routed and allow for rear axle rotation

OVERCARRIAGE / UNDERCARRIAGE

- Torque all mounting bolts properly
- Hydro hoses routed properly
- Brakes are adjusted properly and pedals should depress no more than ½ way
- Brake lines are routed properly, secured and free of pinch and abrasion points

Mounting Bolt Location	Torque
Carriage to Chassis	M16@235lb-ft; M20@450lb-ft
Drive Wheels	175lb-ft + ¼ Turn
Axle Extensions	675 lb-ft
Final Drive Mounting Bolts	475 lb-ft (oiled)
Transmission Mounting Bolts	235 lb-ft

HYDRAULICS

- Hoses cleanly and securely routed with no pinch or abrasion points
- Hydraulic Reservoir & Main Engine Gear Case are filled to the proper level
- Hydrostatic Hose 4-bolt flange cap screws are tightened to proper torque
- No leaks in the hydraulic system
- Torque gear pump coupler to 130lb-ft
- Hoses by header lift manifold do not come in contact with drive shaft on JS9010

Hose Size	Cap Screws Torque
-16	68lb-ft
-20	111lb-ft

ELECTRICAL

- Harnesses are cleanly and properly routed and secured without pinch or abrasion points
- Mechanical Leveling Stops are set so that there is no less than ¾" clearance around the drive tires.
- Left and right limits are set so that there is no less than 1" clearance around the drive tires.

TRANSITION

- Feeder chain links and slats are properly tightened
- Feeder chain is properly tension according to JD specification

FUNCTION CHECKS

- Combine responds properly to manual leveling switch (leveling direction matches button)
- Automatic Leveling System responds properly to changes in slope
- Clinometer has been zeroed and the combine returns to level in automatic mode
- Automatic Header Tilt system keeps the transition parallel to ground as the combine levels
- Manual Header Tilt system responds properly to switch and cycle time is set to 14 seconds
- Ladder pivots and locks into place
- Moving step retracts fully and operates smoothly
- Rear Wheels are properly spaced



WARNING!

Failure to conduct these inspections may result in serious damage to the combine, leveling system or could result in injury.

Adjustments

Rear Axle Spacing

On a combine equipped with a Hillco Leveler the rear axle has a greater rotation range. As a result the rear axle spacing must be changed to prevent shield interference. Refer to the diagram below and the following charts for Hillco's rear axle spacing recommendations.

Rear Axle Position Chart

Standard Rear Axle Position

High Clearance Rear Axle Position

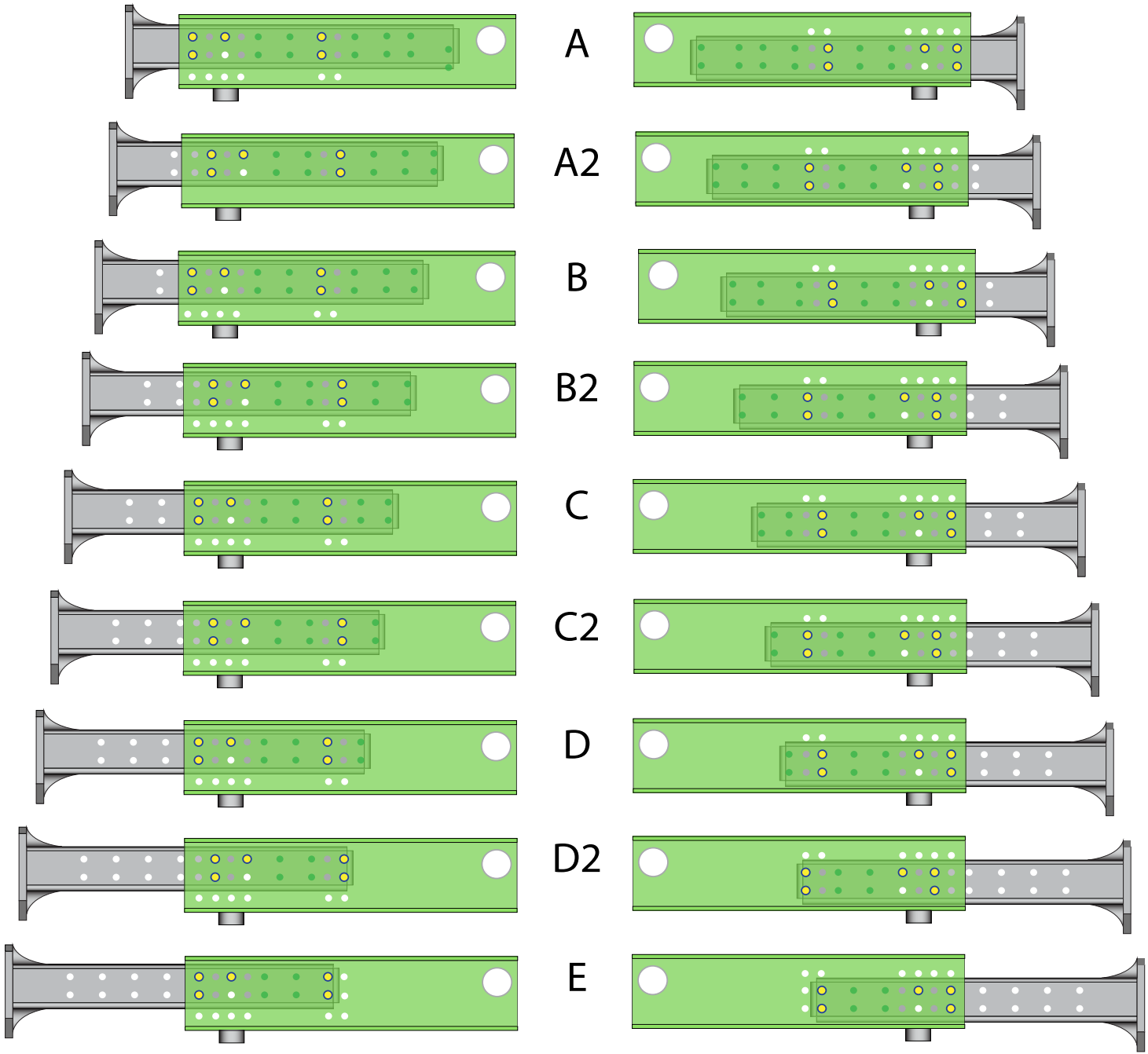

Heavy Duty Rear Axle Spacing

Rear Axle Tire	Rear Axle Position	Center to Center (in)	Outside to Outside (in)	Inside to Inside (in)
480/70R30 (152A8) R1W	A	Not allowed due to rear shielding interference		
	A2	Not allowed due to rear shielding interference		
	B	126.4	146.2	106.6
	B2	130.4	150.2	110.6
	C	134.4	154.2	114.6
	C2	138.4	158.2	118.6
	D	142.4	162.2	122.6
	D2	146.4	166.2	126.6
600/65R28 (154A8) R1W	E	150.4	170.2	130.6
	A	Not allowed due to rear shielding interference		
	A2	Not allowed due to rear shielding interference		
	B	125.5	150.0	101.1
	B2	129.5	154.0	105.1
	C	133.5	158.0	109.1
	C2	137.5	162.0	113.1
	D	141.5	166.0	117.1
28L-26 (158A8) R1	D2	145.5	170.0	121.1
	E	149.5	174.0	125.1
	A	Not allowed due to rear shielding interference		
	A2	Not allowed due to rear shielding interference		
	B	Not allowed due to rear shielding interference		
	B2	140.3	170.9	109.7
	C	144.3	174.9	113.7
	C2	148.3	178.9	117.7
28L-26 (158A8) R2	D	152.3	182.9	121.7
	D2	156.3	186.9	125.7
	E	160.3	190.9	129.7
	A	Not allowed due to rear shielding interference		
	A2	Not allowed due to rear shielding interference		
	B	Not allowed due to rear shielding interference		
	B2	Not allowed due to rear shielding interference		
	C	144.3	174.8	113.7
620/75R26 (166A8) R1W	C2	148.3	178.8	117.7
	D	152.3	182.8	121.7
	D2	156.3	186.8	125.7
	E	160.3	190.8	129.7
	A	Not allowed due to rear shielding interference		
	A2	Not allowed due to rear shielding interference		
	B	Not allowed due to rear shielding interference		
	B2	131.3	157.2	105.5
23.1LR26 (166A8) R1	C	135.3	161.2	109.5
	C2	139.3	165.2	113.5
	D	143.3	169.2	117.5
	D2	147.3	173.2	121.5
	E	151.3	177.2	125.5
	A	Not allowed due to rear shielding interference		
	A2	Not allowed due to rear shielding interference		
	B	Not allowed due to rear shielding interference		
28LR26 (169A8) R1W	B2	131.3	156.4	106.2
	C	135.3	160.4	110.2
	C2	139.3	164.4	114.2
	D	143.3	168.4	118.2
	D2	147.3	172.4	122.2
	E	151.3	176.4	126.2
	A	Not allowed due to rear shielding interference		
	A2	Not allowed due to rear shielding interference		
750/65R26 (166A8) R1W	B	Not allowed due to rear shielding interference		
	B2	140.3	170.8	109.7
	C	144.3	174.8	113.7
	C2	148.3	178.8	117.7
	D	152.3	182.8	121.7
	D2	156.3	186.8	125.7
	E	160.3	190.8	129.7
	A	Not allowed due to rear shielding interference		
A2	Not allowed due to rear shielding interference			
750/65R26 (166A8) R1W	B	Not allowed due to rear shielding interference		
	B2	140.3	171.5	109.1
	C	144.3	175.5	113.1
	C2	148.3	179.5	117.1
	D	152.3	183.5	121.1
	D2	156.3	187.5	125.1
	E	160.3	191.5	129.1
	A	Not allowed due to rear shielding interference		
A2	Not allowed due to rear shielding interference			

Extra Heavy Duty Rear Axle Spacing

Rear Axle Tire	Rear Axle Position	Center to Center (in)	Outside to Outside (in)	Inside to Inside (in)
480/70R30 (152A8) R1W	A	Not allowed due to rear shielding interference		
	A2	Not allowed due to rear shielding interference		
	B	Not allowed due to rear shielding interference		
	B2	134.8	154.6	115.0
	C	138.8	158.6	119.0
	C2	142.8	162.6	123.0
	D	146.8	166.6	127.0
	D2	150.8	170.6	131.0
600/65R28 (154A8) R1W	E	154.8	174.6	135.0
	A	Not allowed due to rear shielding interference		
	A2	Not allowed due to rear shielding interference		
	B	129.6	154.0	105.1
	B2	133.6	158.0	109.1
	C	137.6	162.0	113.1
	C2	141.6	166.0	117.1
	D	145.6	170.0	121.1
28L-26 (158A8) R1	D2	149.6	174.0	125.1
	E	153.6	178.0	129.1
	A	Not allowed due to rear shielding interference		
	A2	Not allowed due to rear shielding interference		
	B	Not allowed due to rear shielding interference		
	B2	143.7	174.3	113.2
	C	147.7	178.3	117.2
	C2	151.7	182.3	121.2
28L-26 (158A8) R2	D	155.7	186.3	125.2
	D2	159.7	190.3	129.2
	E	163.7	194.3	133.2
	A	Not allowed due to rear shielding interference		
	A2	Not allowed due to rear shielding interference		
	B	Not allowed due to rear shielding interference		
	B2	Not allowed due to rear shielding interference		
	C	147.7	178.3	117.1
620/75R26 (166A8) R1W	C2	151.7	182.3	121.1
	D	155.7	186.3	125.1
	D2	159.7	190.3	129.1
	E	163.7	194.3	133.1
	A	Not allowed due to rear shielding interference		
	A2	Not allowed due to rear shielding interference		
	B	Not allowed due to rear shielding interference		
	B2	133.9	159.8	108.1
23.1LR26 (166A8) R1	C	137.9	163.8	112.1
	C2	141.9	167.8	116.1
	D	145.9	171.8	120.1
	D2	149.9	175.8	124.1
	E	153.9	179.8	128.1
	A	Not allowed due to rear shielding interference		
	A2	Not allowed due to rear shielding interference		
	B	Not allowed due to rear shielding interference		
28LR26 (169A8) R1W	B2	133.9	159.0	108.8
	C	137.9	163.0	112.8
	C2	141.9	167.0	116.8
	D	145.9	171.0	120.8
	D2	149.9	175.0	124.8
	E	153.9	179.0	128.8
	A	Not allowed due to rear shielding interference		
	A2	Not allowed due to rear shielding interference		
750/65R26 (166A8) R1W	B	Not allowed due to rear shielding interference		
	B2	144.5	175.1	113.9
	C	148.5	179.1	117.9
	C2	152.5	183.1	121.9
	D	156.5	187.1	125.9
	D2	160.5	191.1	129.9
	E	164.5	195.1	133.9
	A	Not allowed due to rear shielding interference		
750/65R26 (166A8) R1W	A2	Not allowed due to rear shielding interference		
	B	Not allowed due to rear shielding interference		
	B2	144.5	175.7	113.3
	C	148.5	179.7	117.3
	C2	152.5	183.7	121.3
	D	156.5	187.7	125.3
	D2	160.5	191.7	129.3
	E	164.5	195.7	133.3

Lateral Tilt Flow Control Adjustment

For JS5010 and JS7010 Leveling Systems the lateral tilt flow control valve adjusts the speed at which the header rotates. The header should rotate at the chassis' rotation rate. The tilt speed is a compromise between manual tilt mode and automatic tilt mode. The rotation rate is set at the factory; however with larger header configurations it may be necessary to adjust the header's rotational rate.

To test the header rotation rate, push the tilt button to the left until the tilt frame is rotated to the left limit. Push the tilt button to the right until the tilt frame reaches its right limit. The cycle time should meet the specification of 14 seconds.

Specification

Left-to-Right Cycle Time-14 seconds

If the cycle time is shorter than the specification, turn the flow control set screw clockwise a quarter turn at a time until the cycle time meets the specification. If the cycle time is longer than the specification, turn the flow control screw counterclockwise a quarter turn at a time until the cycle time meets the specification. This specification ensures that tilt speed is adequate for manual operation. With some header configurations this tilt speed may cause the automatic mode to be unstable. Hillco recommends adjusting the Contour Master's sensitivity until it becomes stable. Refer to the combine's operators manual for Contour Master adjustments.

For changing the header tilt speed on a JS9010 Leveling System consult the John Deere Operator's Manual.

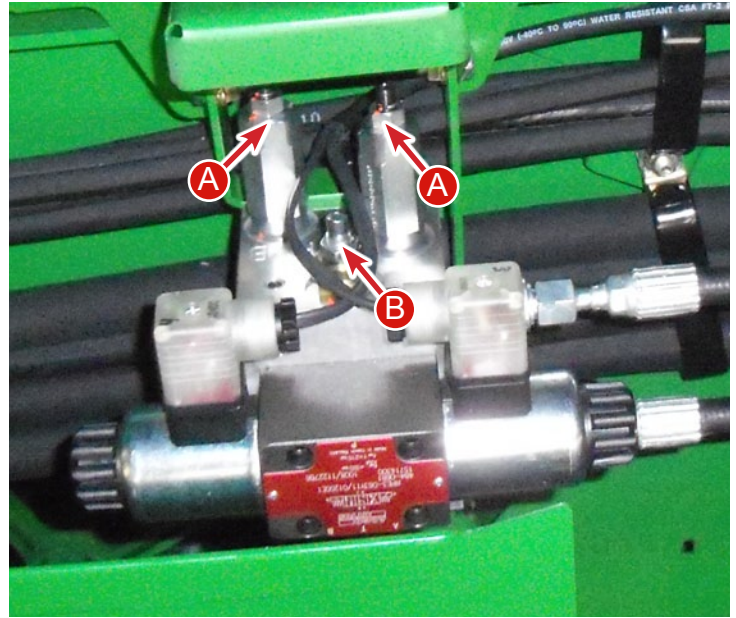

A - Trim Relief Valves
B - Tilt Flow Control Valves

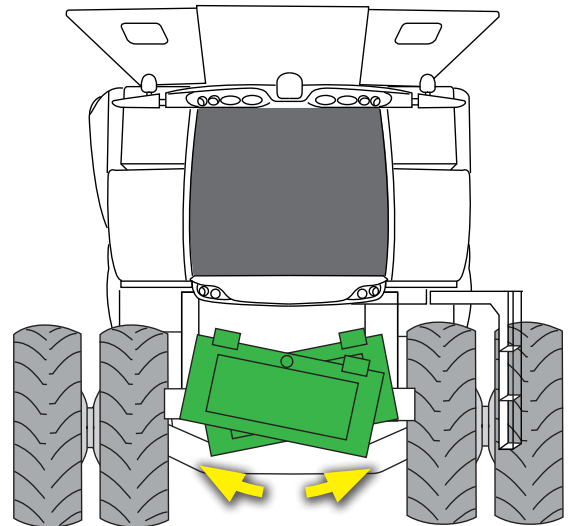

14 second rotation time from one side to other



IMPORTANT!

The pressure relief valve is pre-set at the factory. Changing the setting may cause damage to the tilt frame or hydraulic system. However, in very large header configurations, it may be necessary to change the setting. Contact your dealer to reset the relief valve.

Transition Fore/Aft Adjustment Procedure

1. Loosen the clamping bolts and the pivot bolt on each side of the feeder house.
2. Loosen the jam nuts on the turnbuckles.
3. Adjust the turnbuckles until the desired header angle is achieved.
4. Tighten the jam nuts.
5. Tighten the clamping and pivot bolts to 153 lb-ft of torque.

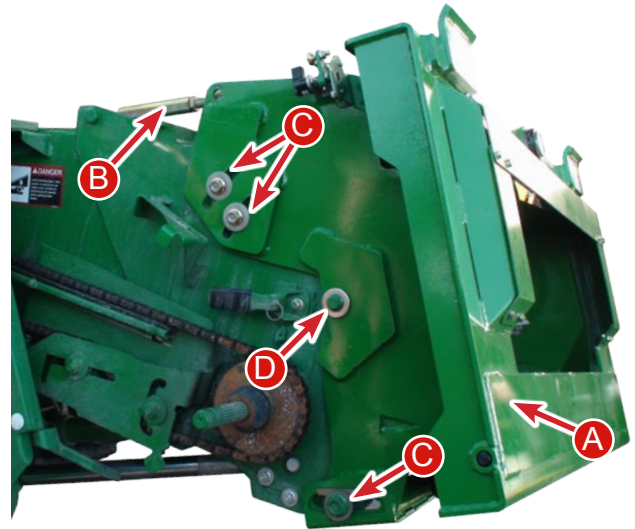
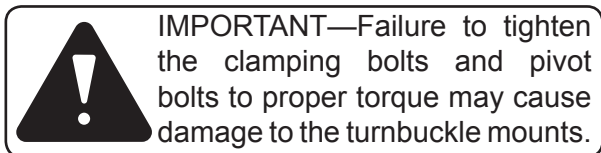
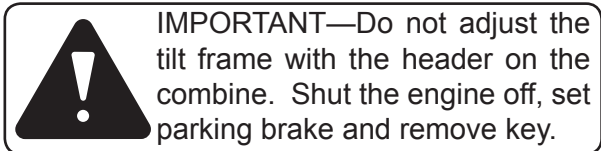

- A - Transition
- B - Turnbuckle
- C - Clamping Bolts
- D - Pivot Bolts

Lower Feeder Drum Stop Adjustment

The Hillco leveling system does not change the feeder drum stop adjustment. Refer to the John Deere Operator's Manual for your combine for the feeder drum stop adjustment.

Adjusting the Leveling Zero Point

Make sure combine is parked on level ground.

Start the combine.

Enter setup mode by holding both the auto/manual button (A) AND the auto steer resume button on the hydro handle (B) for 7 seconds (If the combine park brake is not set or the hydro handle is not in the neutral position it will not enter setup mode).

Once the system is in setup mode the orange light near the auto/manual button will begin to blink.

Note:

While in setup mode the automatic function of the leveling system is disabled. Likewise, the level limits are disabled to allow full range of motion of the leveling system for setup purposes.

Manually level the combine with the level left and level right buttons (C) to obtain level. (A torpedo level on the floor of the cab is a good method to make sure the chassis is level)

With the combine level, press and hold the #2 resume button (D) on the hydrostat handle for 1 second.

Exit Setup Mode by holding the auto/manual button (A) AND the auto steer resume button on the hydro handle (B) for 7 seconds.



IMPORTANT—While in Setup Mode the leveling system will level slower than in normal operational mode to prevent damage.

Mechanical Leveling Cylinder Stops

In the event of electrical controller or hydraulic failure Hillco requires installation of mechanical Leveling Cylinder Stops on combines equipped with oversized drive tires. The Leveling Cylinder Stops will prevent side panel or tire damage. Contact Hillco for further details.

Stops are available in two thicknesses, 5/8" and 1/8" for adequate adjustment.

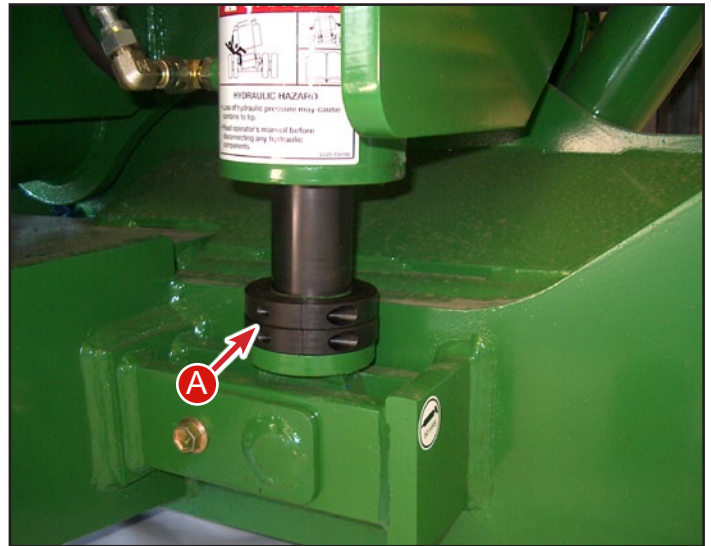

A - Mechanical Leveling Cylinder Stops
(5/8" thick Cylinder Stops Shown)

Set the Cylinder Stops

- After setting the Maximum Level lean the combine over one direction until the controller senses maximum position and the chassis stops rotating. There should be no less than 1" between the tire and the closest contact point.
- Insert stops into the cylinder to fill the gap between the Rod Base Top and Cylinder Bottom. The safety stop is used to stop leveling only in the event of hydraulic or electrical failure.
- Repeat for other direction.

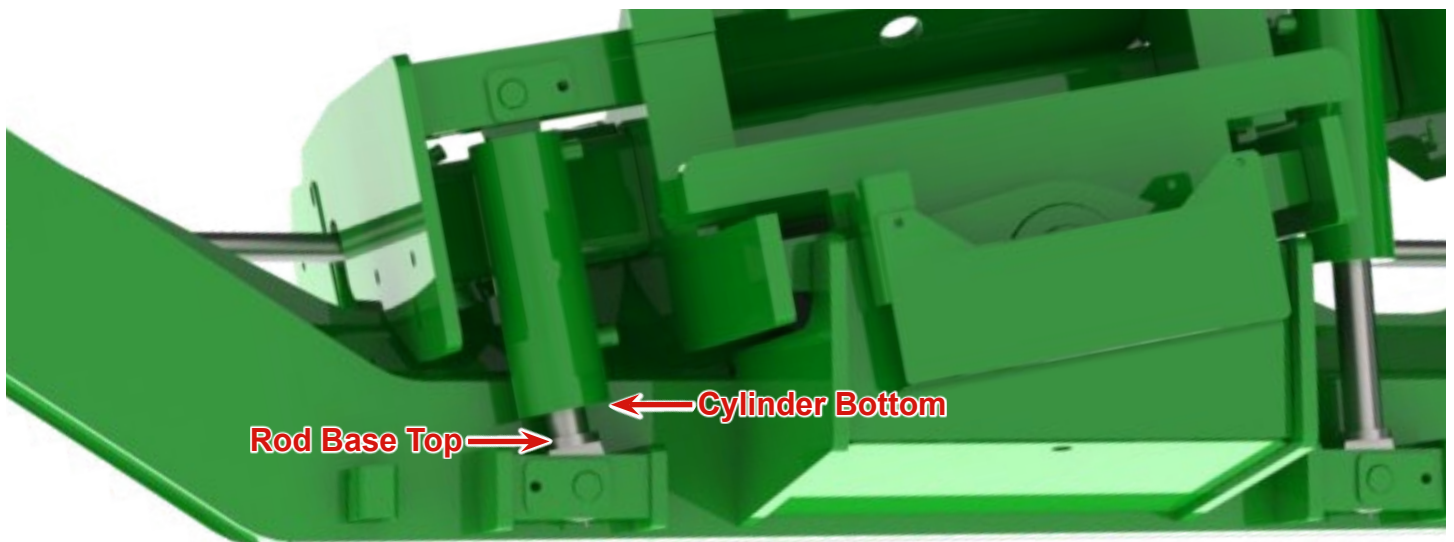
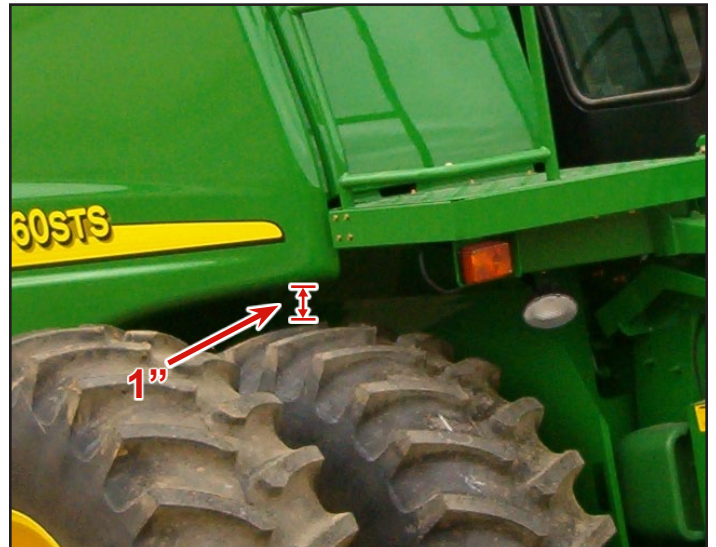

Maximum Leveling Calibration

1. Make sure combine is parked on Level Ground
2. Ensure that the steps in the Mechanical Leveling Cylinder Stops section on the previous page have been completed prior to calibrating the maximum level.
3. Start the combine.
4. Enter setup mode by holding both the auto/manual button (A) AND the auto steer resume button on the hydro handle (B) for 7 seconds (If the combine park brake is not set or the hydro handle is not in the neutral position it will not enter setup mode).
5. Manually tilt the combine to the left such that the cylinder bottoms out or so that there is 1" of clearance between the tire and closest contact point. Rotate the leveling system slightly back towards level so that there is a 1/8" gap between the collar and the cylinder's packing gland (See picture below).
6. When there is and a 1/8" gap between the collar and the packing gland press and hold the #3 resume button (C) on the hydrostat handle for 1 second.
7. Repeat step 3 this time leveling to the right. When there is a 1/8" gap between the collar and the packing gland press and hold the #1 resume button (D) on the hydrostat handle for 1 second.
8. Manually return the combine to the level position.
9. Exit Setup Mode by holding the auto/manual button (A) AND the auto steer resume button on the hydro handle (B) for 7 seconds. Check that the orange light near the auto/manual button has stopped blinking to be sure the system has left setup mode.

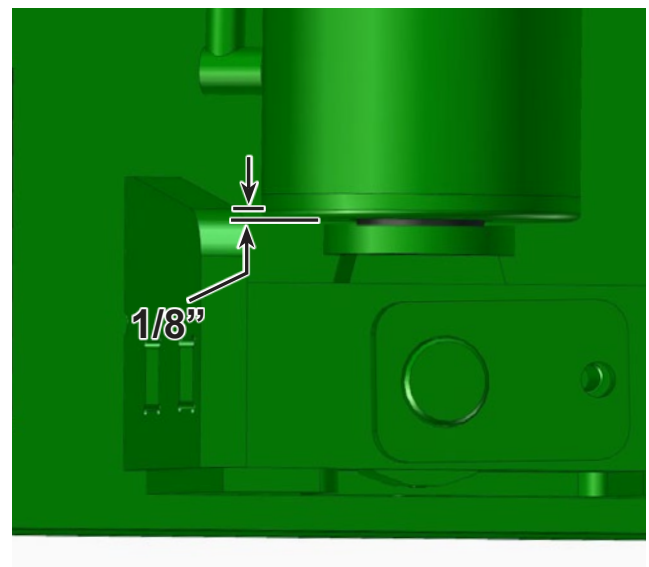

 **CAUTION**

Caution—In some tire configurations, the tire can contact the gull wing doors. In this case, the maximum level must be adjusted to prevent tire contact with the combine chassis. However, to prevent chassis and tire damage in the event of a hydraulic or electrical failure, Hillco strongly recommends that cylinder stops be installed on the leveling cylinders. Cylinder stops may be ordered from Hillco. Hillco is not responsible for chassis damage that occurs due to the lack of appropriate cylinder stops.

Header Tilt Setup

Contour Master functionality should have been turned on during the installation process. If it is not functional follow the below instructions to activate the Contour Master function in the combine's Command Center.

1. Key switch on.
2. Select the Main Menu Icon  in the lower right corner of the Command Center. Once in the Menu select the "Message Center" application icon.

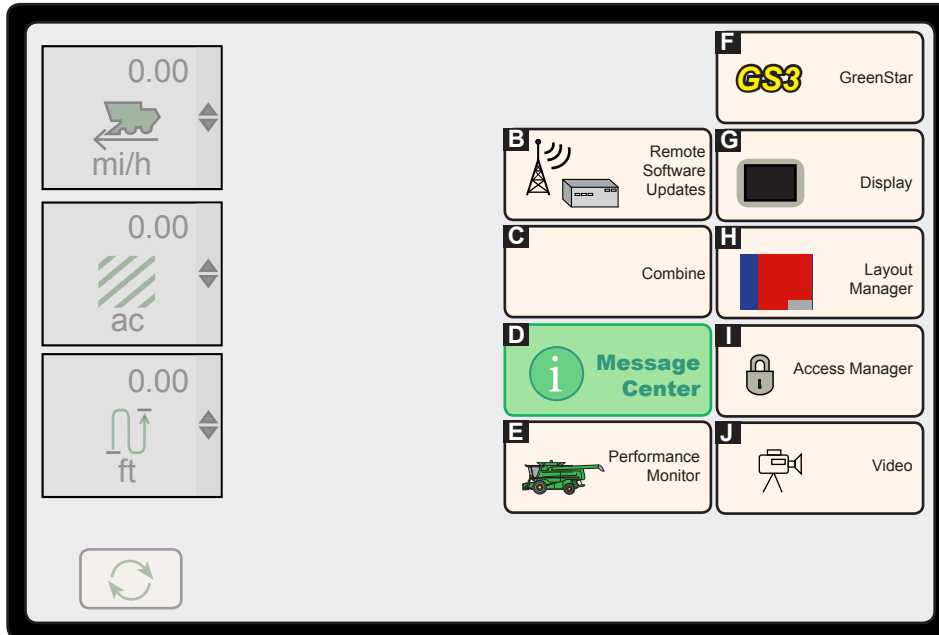

3. Select the diagnostic address icon. Item "G" of graphic.

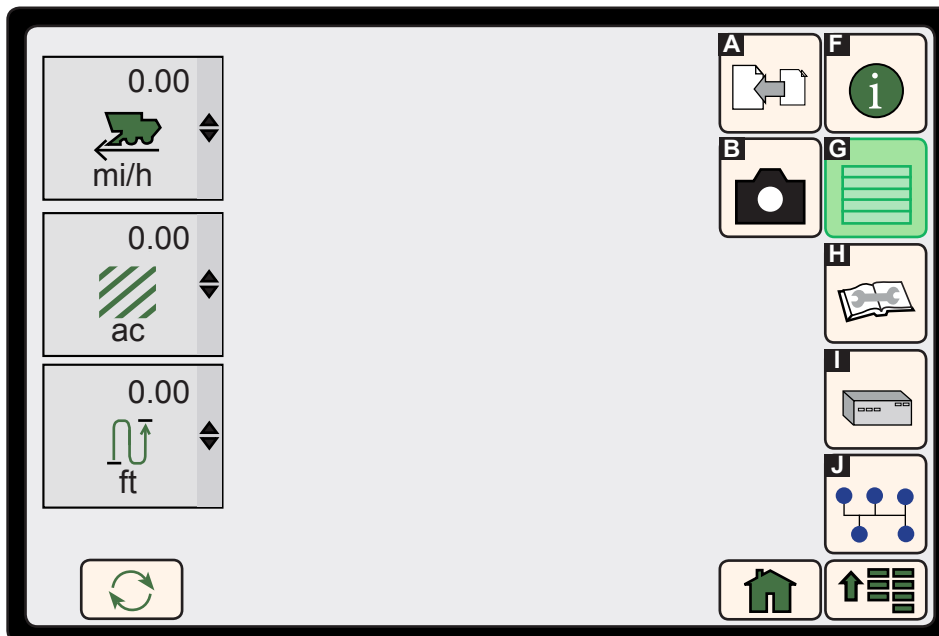

4. Select the device drop down menu.
5. Use the down arrow to scroll through the menu list of controls.
6. Select "CAB.001 Implement".

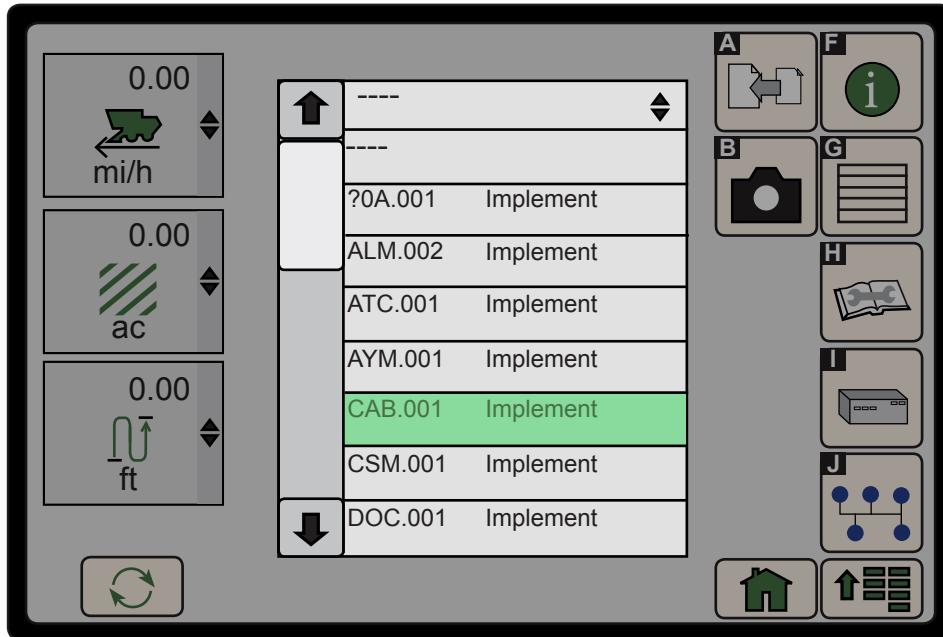

7. Scroll down to "111 Input" and select this setting.

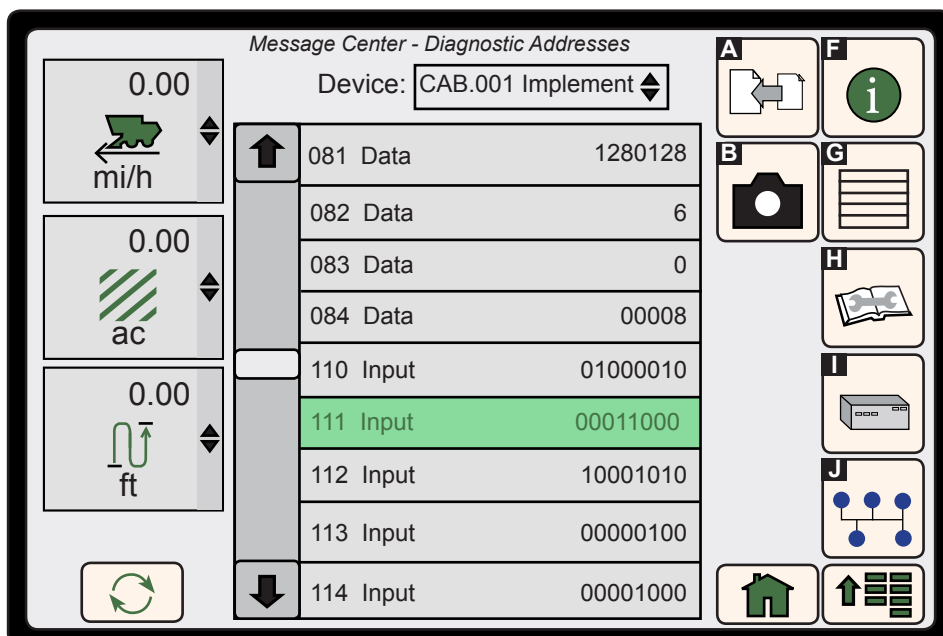

- Select the XXXnXXXX numbering sequence. Change the “n” position to a “1”. Leave all other values as they originally were.

NOTE: When modifying an address, any zeros appearing to the right of the modified bit in the address value (A) must be entered. Zeros appearing to the left of the first whole digit do not have to be entered unless they are being changed. Example: 00011100 would be entered as 11100. If the third bit is modified, the entry would be 111100. Use the keypad screen to enter the desired address value.

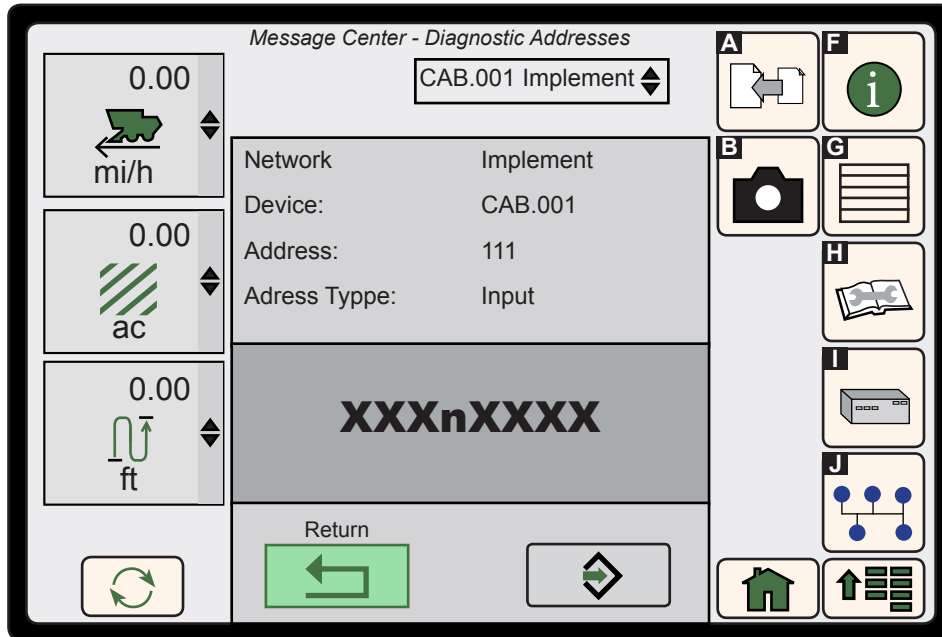

- Select Enter Icon  to confirm the number.

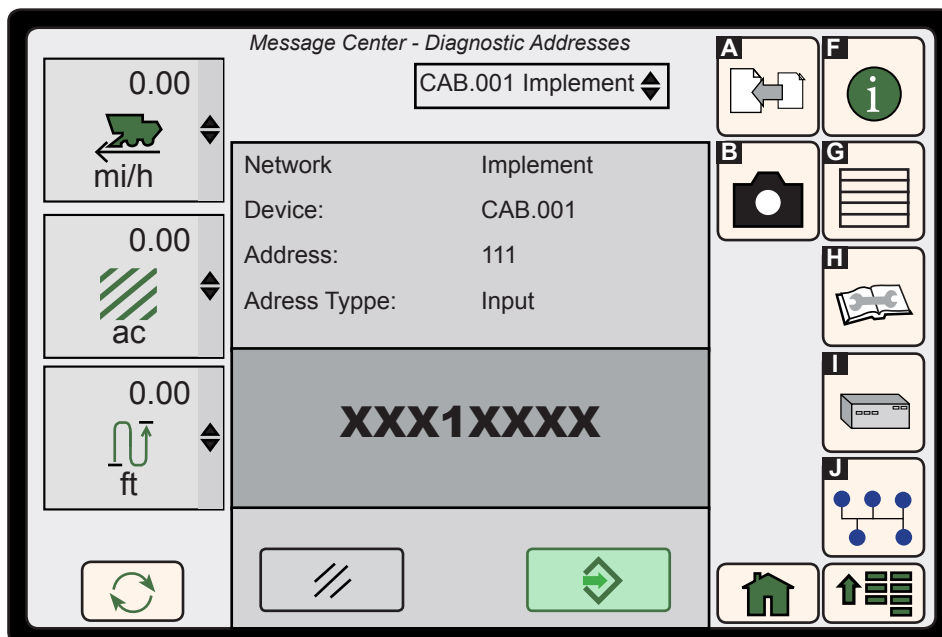

10. Select the  icon.

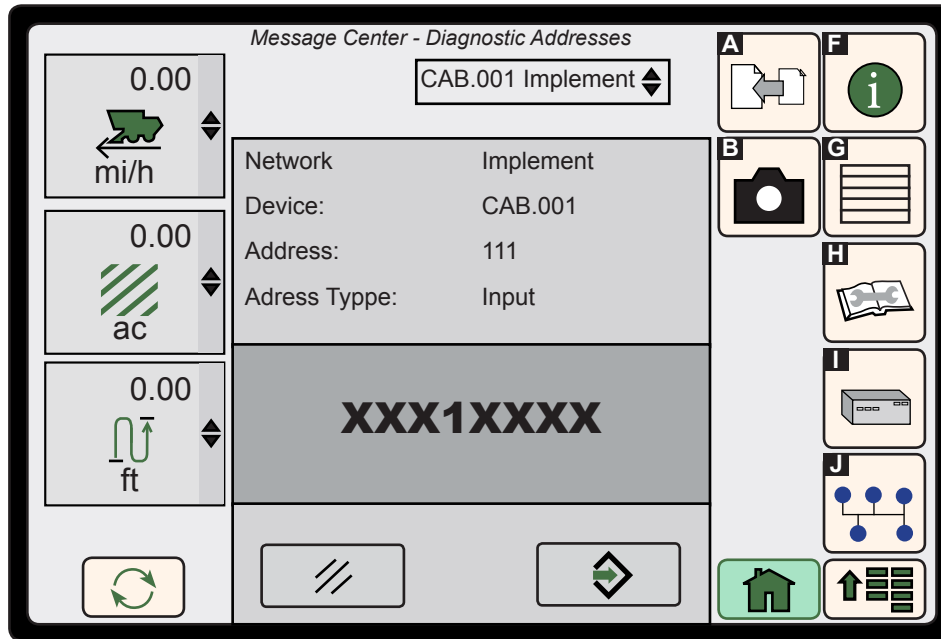

11. The below message will appear. Select “Close Diagnostics” and then select “OK”

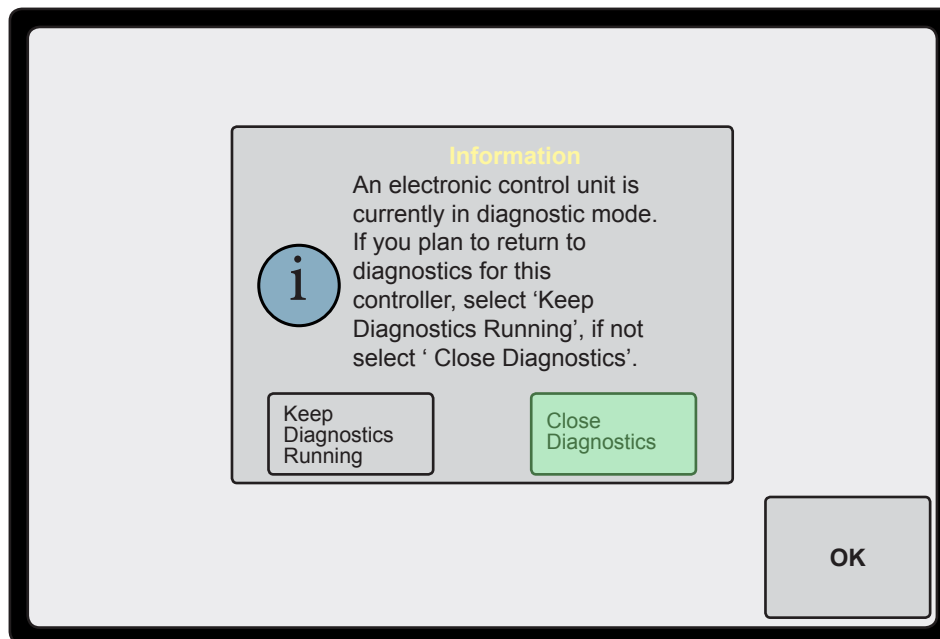

Contour Master is now functional.

To calibrate the header tilt refer to the John Deere Operator’s Manual.

Header Tire Compatibility Chart

Front Tire Selection/Header Compatibility Chart for S550

To determine the tire / header compatibility select the tire size in the first column and match it to the proper header model number from the top row.

NR = Not Recommended X = Recommended

Front Tire Size	Front Tire / Header Compatibility Chart													
	Cornhead				BPU	Rigid			Flex				Draper	
	606C	606C-SM	608C	608C-SM	615	622R	625R	630R	620F	622F	625F	630F	625D	630D
800/65R32 (172A8) R1W	X	X	X	X	X	X	X	X	X	X	X	X	X	X
800/65R32 R1 (172A8) or 30.5LR-32 3* R1 (170A8)	X	X	X	X	X	X	X	X	X	X	X	X	X	X
800/70R38 (173A8) R1W	X	X	X	X	X	X	X	X	X	X	X	X	X	X
480/80R42 R1 Duals (154A8)	X	X	X	X	X	X	X	X	X	X	X	X	X	X
520/85R38 R1 Duals (155A8)	X	X	X	X	X	X	X	X	X	X	X	X	X	X

Rear Tire Selection/Header Compatibility Chart for S550 Combines

To determine the tire / header compatibility select the tire size in the first column and match it to the proper header from the top row.

NR = Not Recommended X = Recommended

Rear Tire Size	Rear Tire / Header Compatibility Chart													
	Cornhead				BPU	Rigid			Flex				Draper	
	606C	606C-SM	608C	608C-SM	615	622R	625R	630R	620F	622F	625F	630F	625D	630D
480/70R30 (152A8) R1W	X	X	X	X	X	X	X	X	X	X	X	X	X	X

Front Tire Selection/Header Compatibility Chart for S660-S670 Combines

To determine the tire / header compatibility select the tire size in the first column and match it to the proper header model number from the top row.

NR = Not Recommended X = Recommended

Front Tire Size	Front Tire / Header Compatibility Chart																						
	Cornhead						BPU	Rigid				Flex					Draper			Flex Draper			
	606C	606C-SM	608C	608C-SM	612C	612C-SM	615	622R	625R	630R	620F	622F	625F	630F	635F	625D	630D	635D	640D	635FD	635FD w/ ta	640FD	640FD w/ ta
**800/65R32 (172A8) R1W	X	X	X	X	NR	NR	X	X	X	X	X	X	X	X	X	NR	NR	NR	NR	NR	NR	NR	NR
**800/65R32 R1 (172A8) or 30.5LR-32 3* R1 (170A8)	X	X	X	X	NR	NR	X	X	X	X	X	X	X	X	NR	NR	NR	NR	NR	NR	NR	NR	NR
900/60R32 R1 (176A8)	X	X	X	X	X	X	X	X	X	X	X	X	X	X	X	X	X	X	X	X	X	X	X
900/60R32 R1W (176A8)	X	X	X	X	X	X	X	X	X	X	X	X	X	X	X	X	X	X	X	X	X	X	X
900/65R32 R2 (178A8)	X	X	X	X	X	X	X	X	X	X	X	X	X	X	X	X	X	X	X	X	X	X	X
**800/70R38 (173A8) R1W	X	X	X	X	X	NR	X	X	X	X	X	X	X	X	X	NR	NR	NR	NR	NR	NR	NR	NR
**480/80R42 R1 Duals (154A8)	X	X	X	X	X	NR	X	X	X	X	X	X	X	X	X	X	NR	NR	X	NR	NR	NR	NR
**520/85R38 R1 Duals (155A8)	X	X	X	X	X	X	X	X	X	X	X	X	X	X	X	X	X	NR	X	X	X	X	NR
*800/70R38 R1W (181A8)	X	X	X	X	X	X	X	X	X	X	X	X	X	X	X	X	X	X	X	X	X	X	X
76x50-32 16PR HF3	X	X	X	X	X	X	X	X	X	X	X	X	X	X	X	X	X	X	X	X	X	X	X
650/85R38 R1W Duals (173A8)	X	X	X	X	X	X	X	X	X	X	X	X	X	X	X	X	X	X	X	X	X	X	X
*520/85R42 R1 Duals (162A8)	X	X	X	X	X	X	X	X	X	X	X	X	X	X	X	X	X	X	X	X	X	X	X
520/85R42 R1 Duals (157A8)	X	X	X	X	X	X	X	X	X	X	X	X	X	X	X	X	X	X	X	X	X	X	X
520/85R42 R2 Duals (157A8)	X	X	X	X	X	X	X	X	X	X	X	X	X	X	X	X	X	X	X	X	X	X	X*
*520/85R42 R1W Duals (162A8)	X	X	X	X	X	X	X	X	X	X	X	X	X	X	X	X	X	X	X	X	X	X	X

**S660 Only
*S670 Only

Rear Tire Selection/Header Compatibility Chart for S660-S670 Combines

To determine the tire / header compatibility select the tire size in the first column and match it to the proper header from the top row.

NR = Not Recommended X = Recommended

Rear Tire Size	Rear Tire / Header Compatibility Chart																						
	Cornhead						BPU	Rigid				Flex					Draper			Flex Draper			
	606C	606C-SM	608C	608C-SM	612C	612C-SM	615	622R	625R	630R	620F	622F	625F	630F	635F	625D	630D	635D	640D	635FD	635FD w/ ta	640FD	640FD w/ ta
480/70R30 (152A8) R1W	NR	NR	X**	X**	X**	X	NR	NR	NR	NR	NR	NR	NR	X**	X**	X**	X	X	X	X	X	X	X
*750/65R26 R1W (166A8)	X	X	X	X	X	X	X	X	X	X	X	X	X	X	X	X	X	X	X	X	X	X	X
28L-26 12PR R1 (158A8)	X	X	X	X	X	X	X	X	X	X	X	X	X	X	X	X	X	X	X	X	X	X	X
28L-26 12PR R2 (158A8)	X	X	X	X	X	X	X	X	X	X	X	X	X	X	X	X	X	X	X	X	X	X	X
600/65R28 R1W (154A8)	X	X	X	X	X	X	X	X	X	X	X	X	X	X	X	X	X	X	X	X	X	X	X

ta= Top Auger

Front Tire Selection/Header Compatibility Chart for S680-690 Combines

To determine the tire / header compatibility select the tire size in the first column and match it to the proper header model number from the top row.

NR = Not Recommended X = Recommended

Front Tire Size	Front Tire / Header Compatibility Chart																										
	Cornhead										BPU	Rigid			Flex					Draper			Flex Draper				
	606C	606C-SM	608C	608C-SM	612C	612C-SM	616C	616C-SM	618C	618C-SM	615	622R	625R	630R	620F	622F	625F	630F	635F	625D	630D	635D	640D	635FD	635FD w/ ta	640FD	640FD w/ ta
900/60R32 R1 (176A8)	X	X	X	X	NR	NR	NR	NR	NR	NR	X	X	X	X	X	X	X	X	X	X	NR	NR	NR	NR	NR	NR	NR
900/60R32 R1W (176A8)	X	X	X	X	NR	NR	NR	NR	NR	NR	X	X	X	X	X	X	X	X	X	X	NR	NR	NR	NR	NR	NR	NR
900/65R32 R2 (178A8)	X	X	X	X	X	NR	NR	NR	NR	NR	X	X	X	X	X	X	X	X	X	X	X	X	NR	X	X	NR	NR
800/70R38 R1W (181A8)	X	X	X	X	X	X	X	X	X	X	X	X	X	X	X	X	X	X	X	X	X	X	X	X	X	X	X
76x50-32 16PR HF3	X	X	X	X	X	X	X	X	X	NR	X	X	X	X	X	X	X	X	X	X	X	X	X	X	X	X	X
650/85R38 R1W Duals (173A8)	X	X	X	X	X	X	X	X	X	X	X	X	X	X	X	X	X	X	X	X	X	X	X	X	X	X	X
520/85R42 R1 Duals (162A8)	X	X	X	X	X	X	X	X	X	X	X	X	X	X	X	X	X	X	X	X	X	X	X	X	X	X	X
520/85R42 R1W Duals (162A8)	X	X	X	X	X	X	X	X	X	X	X	X	X	X	X	X	X	X	X	X	X	X	X	X	X	X	X

**S680 Only

*S690 Only

Rear Tire Selection/Header Compatibility Chart for S680-690 Combines

To determine the tire / header compatibility select the tire size in the first column and match it to the proper header from the top row.

NR = Not Recommended X = Recommended

Rear Tire Size	Rear Tire / Header Compatibility Chart																										
	Cornhead										BPU	Rigid			Flex					Draper			Flex Draper				
	606C	606C-SM	608C	608C-SM	612C	612C-SM	616C	616C-SM	618C	618C-SM	615	622R	625R	630R	620F	622F	625F	630F	635F	625D	630D	635D	640D	635FD	635FD w/ ta	640FD	640FD w/ ta
750/65R26 R1W (166A8)	X	X	X	X	X	X	X	X	X	X	X	X	X	X	X	X	X	X	X	X	X	X	X	X	X	X	X
620/75R26 R1W (166A8)	X	X	X	X	X	X	X	X	X	X	X	X	X	X	X	X	X	X	X	X	X	X	X	X	X	X	X
23.1LR26 R1	X	X	X	X	X	X	X	X	X	X	X	X	X	X	X	X	X	X	X	X	X	X	X	X	X	X	X
28LR26 R1W (169A8)	X	X	X	X	X	X	X	X	X	X	X	X	X	X	X	X	X	X	X	X	X	X	X	X	X	X	X

ta= Top Auger

Decal Placement

A - Right cab window

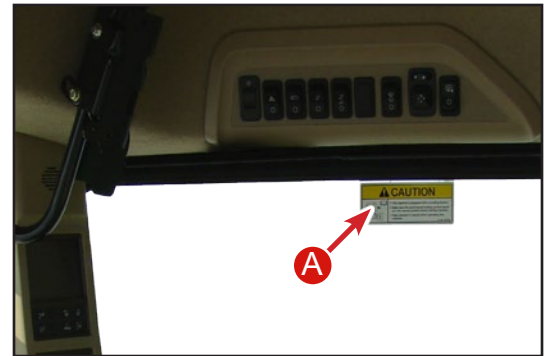
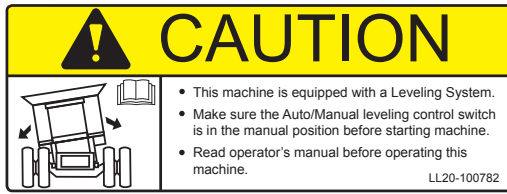

B - Leveling cylinder and manifold

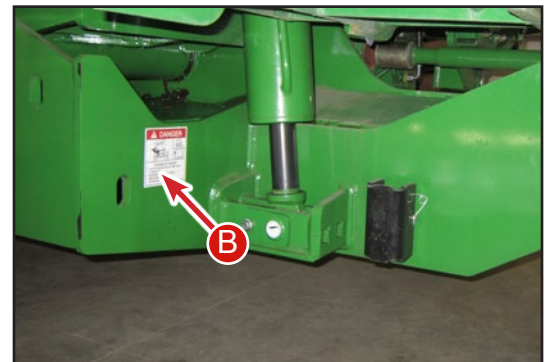
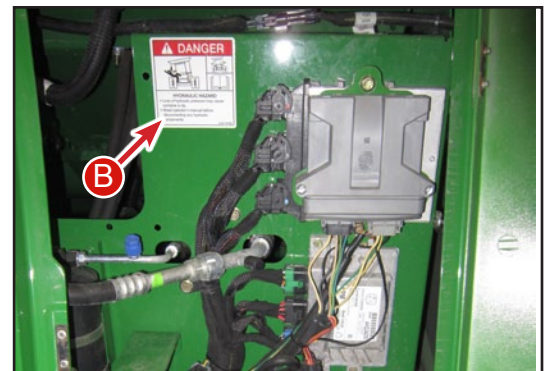

C - Leveling system hazard (Located between the second and third step)

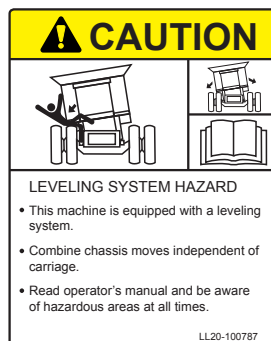

D - Back of undercarriage

⚠ DANGER



AVOID CRUSHING INJURY
Install safety stops on the main leveling cylinders before performing repair or maintenance on the leveling system to prevent accidental tipping of combine chassis.



LL-143621

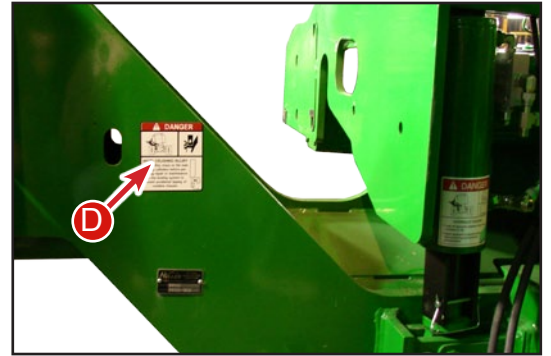

E - Rear drop axle (left and right sides)

⚠ DANGER



CRUSHING HAZARD
To prevent serious injury or death:

- Keep all persons and objects clear while any part of this machine is in motion.

LL20-100783



F - Transition header hooks

⚠ DANGER



PINCH POINT HAZARD

- Keep hands, feet and body away from moving parts.
- Do not stand or climb on machine when operating.
- Hazard occurs during leveling and header trim.

LL20-100784

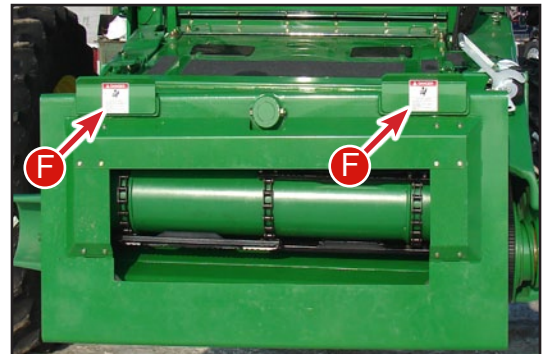

G - Side panel of combine (left and right)



Leveling System Specifications

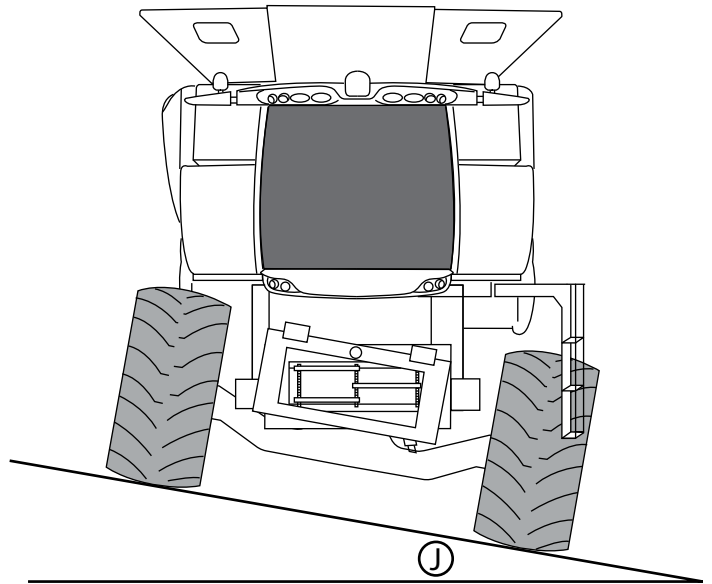
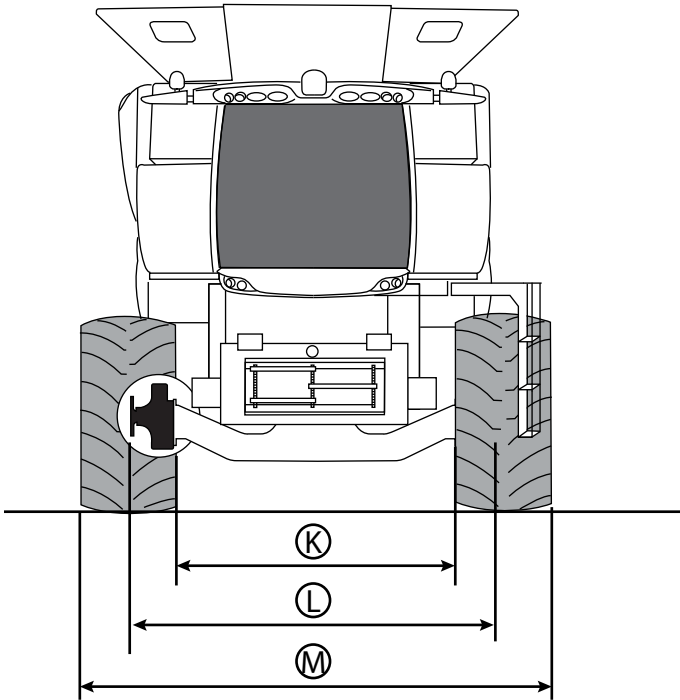
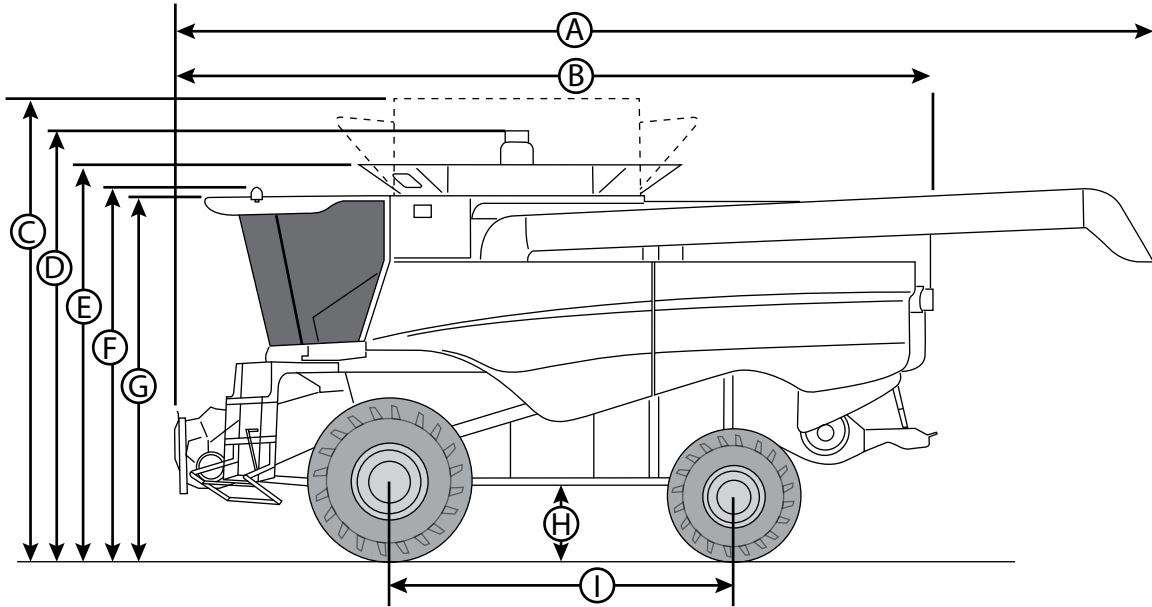

NOTE: Dimensions are approximate and subject to change without notice.

Dimension Reference Points are on the previous page.

Dimension	JS9010	JS7010	JS5010
	900/60R32 Front Tires 620/75R26 Rear Tires	900/60R32 Front Tires 480/70R30 Rear Tires	30.5LR32 Front Tires 480/70R30 Rear Tires
John Deere Models	S680 & S690	S660 & S670	S550
A	36 ft 3 in, (22 ft 5 in Standard Unloading Auger)	33 ft 6 in, (22 ft 5 in Standard Unloading Auger)	30 ft 11 in (18 ft 5 in Unloading Auger)
B	28 ft 1 in	28 ft 2 in	27 ft 9 in
C	16 ft 3 in (400 bu. Folding)	16 ft 2 in (300 bu. Folding)	NA
D	15 ft 10 in	15 ft 9 in	14 ft 10 in
E	15 ft 1 in (400 bu. Extensions)	15 ft (300 bu. Extensions)	13 ft 9 in
F	13 ft 2 in	13 ft 3 in	13 ft
G	13 ft	13 ft	12 ft 10 in
H	2 ft 2 in	2 ft 2 in	1 ft 11 in
I	12 ft 11 in	12 ft 11 in	12 ft 11 in
J	18% (10.2°)	18% (10.2°)	18% (10.2°)
K ^a	10 ft 1 in	8 ft 7 in (Narrow UC), 10 ft 1 in (Std UC)	8 ft 10 in (Narrow UC), 10 ft 1 in (Narrow UC with dual extensions)
L ^a	12 ft 6 in	10 ft 11 in (Narrow UC), 12 ft 6 in (Std UC)	10 ft 11 in (Narrow UC), 12 ft 6 in (Narrow UC with dual extensions)
M ^a	15 ft 11 in	14 ft 3 in (Narrow UC), 15 ft 11 in (Std UC)	14 ft (Narrow UC), 15 ft 7 in (Narrow UC with dual extensions)
Leveling Controller	Clinometer (Accuracy +/- 3/4°)		
Leveling Speed	Proportional Control with Auto / Manual		
Leveling Hydraulic System	Integrated into Combine's Close Center Hydraulics	Gear Pump	Gear Pump
Header Lateral Tilt Control	Hydraulic Master / Slave Cylinder w/ Auto/Manual Override		
Feeder Transition	Extended Feeder Chain		
Weight added to combine	4,100 lbs	4,100 lbs	3,700 lbs

^aDue to different tire configurations, row spacings, axle configurations, wheel offsets, axle positions and spindles types, machine widths will vary. Measurements given in chart are for minimum and maximum widths with single drive tires. For more detailed width information please contact Hillco.

Electrical Schematics

JS5010 Electrical Leveling Schematic
SN 13001-13999

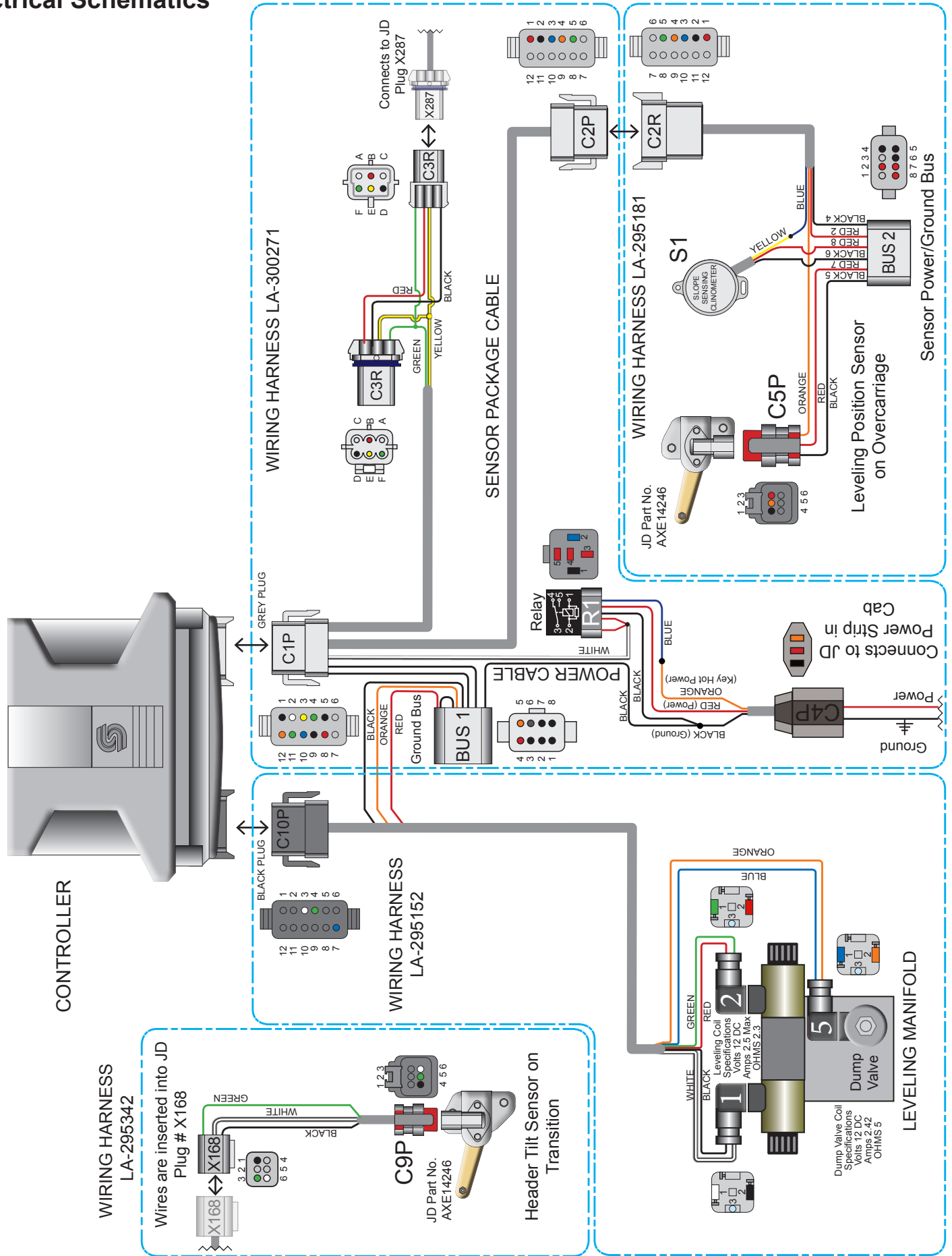

JS5010 Electrical Leveling Schematic
SN 13001-13999

C1P

Location - Controller

PIN	COLOR	FUNCTION	To
1	BLACK	Ground	Bus 1 pin 8
2	WHITE	Power (Keyed)	R1 pin 4,5
3	YELLOW	CAN High	C3R pin 5
4	GREEN	CAN Low	C3R pin 6
5	BLACK	Ground	C3R pin 4
6	-		
7	-		
8	RED	Sensor Power	C2P pin 1
9	BLACK	Sensor Ground	C2P pin 2
10	BLUE	Left/Right Clinometer	C2P pin 3
11	GREEN	Fore/Aft Clinometer	C2P pin 5
12	ORANGE	OC Potentionmeter	C2P pin 4

C2P

Location - Overcarriage

PIN	COLOR	FUNCTION	To
1	RED	Sensor Power	C1P pin 8
2	BLACK	Sensor Ground	C1P pin 9
3	BLUE	Left/Right Clinometer	C1P pin 10
4	GREEN	Fore/Aft Clinometer	C1P pin 11
5	ORANGE	OC Potentionmeter	C1P pin 12
6	-		
7	-		
8	-		
9	-		
10	-		
11	-		
12	-		

C2R

Location - Overcarriage

PIN	COLOR	FUNCTION	To
1	RED	Sensor Power	Bus 2 pin 2
2	BLACK	Sensor Ground	Bus 2 pin 4
3	BLUE	Left/Right Clinometer	S1 Yellow
4	GREEN	Fore/Aft Clinometer	S2 Yellow
5	ORANGE	OC Potentionmeter	C5P pin 2
6	-		
7	-		
8	-		
9	-		
10	-		
11	-		
12	-		

Bus 1

Location - Below Controller

PIN	COLOR	FUNCTION	To
1	BLACK	Combine Ground	C4P pin 3
2	BLACK	Ground Jumper	Bus 1 pin 3
3	BLACK	Ground Jumper	Bus 1 pin 2
4	BLACK	Can Ground	C1P pin 5
5	ORANGE	Manifold Ground	C6R pin 5
6	BLACK	Manifold Ground	C6R pin 3
7	RED	Manifold Ground	C6R pin 1
8	BLACK	Controller Ground	C1P pin 1

C4P

Location - Engine Compartment

PIN	COLOR	FUNCTION	To
-	BLUE/ ORANGE	Key Power	R1 pin 2
-	RED	Power	R1 pin 3
-	BLACK	Ground	R1 pin 1
-	BLACK	Ground	Bus 1 pin 1

C3R

Location - Below Controller

PIN	COLOR	FUNCTION	To
A	-		
B	RED	CAN Power	C3R pin 2
C	-		
E	Black 2	CAN Ground	C3R pin 4
F	Yellow	CAN High	C1P pin 3
G	Green 2	CAN Low	C1P pin 4

Bus 2

Location - Overcarriage

PIN	COLOR	FUNCTION	To
1	-		
2	RED	Sensor Power	C2R Pin 1
3	-		
4	BLACK	Sensor Ground	C2R Pin 2
5	BLACK	Sensor Ground	C5P pin 1
6	BLACK	Sensor Ground	S1 Black
7	RED	Sensor Power	C5P pin 3
8	RED	Sensor Power	S1 Red

C5P

Location - Overcarriage

PIN	COLOR	FUNCTION	To
1	BLACK	Sensor Ground	Bus 2 pin 5
2	ORANGE	OC Potentionmeter	C2R pin 4
3	RED	Sensor Power	Bus 2 pin 7
4	-		
5	-		
6	-		

R1

Location - Engine Compartment

PIN	COLOR	FUNCTION	To
1	BLACK	Ground	C4P pin 3
2	BLUE	Key Power	C4P pin 1
3	RED	Power In	C4P pin 2
4	RED	Not Used	C1P pin 2
5	RED	Power Out	C1P pin 2

C9P

Location - Right side of Transition

PIN	COLOR	FUNCTION	To
1	-		
2	-		
3	-		
4	BLACK	Sensor Ground	X168 pin 1
5	GREEN	TA Potentionmeter	X168 pin 3
6	WHITE	Sensor Power	X168 pin 6

X168

Location - Top of Feeder House

PIN	COLOR	FUNCTION	To
1	BLACK	Sensor Ground	C9P pin 4
2	-		
3	GREEN	TA Sensor Output	C9p pin 5
4	-		
5	-		
6	WHITE	Sensor Power	C9P pin 6

C10P

Location - Below Controller

PIN	COLOR	FUNCTION	To
1	-		
2	-		
3	WHITE	#1 Valve Power	C6R pin 6
4	GREEN	#2 Valve Power	C6R pin 2
5	-		
6	-		
7	BLUE	#5 Valve Power	C6R pin 4
8	-		
9	-		
10	-		
11	-		
12	-		

JS7010 Electrical Leveling Schematic
SN 13001-13999

*See following pages for information regarding each plug and receptacle.

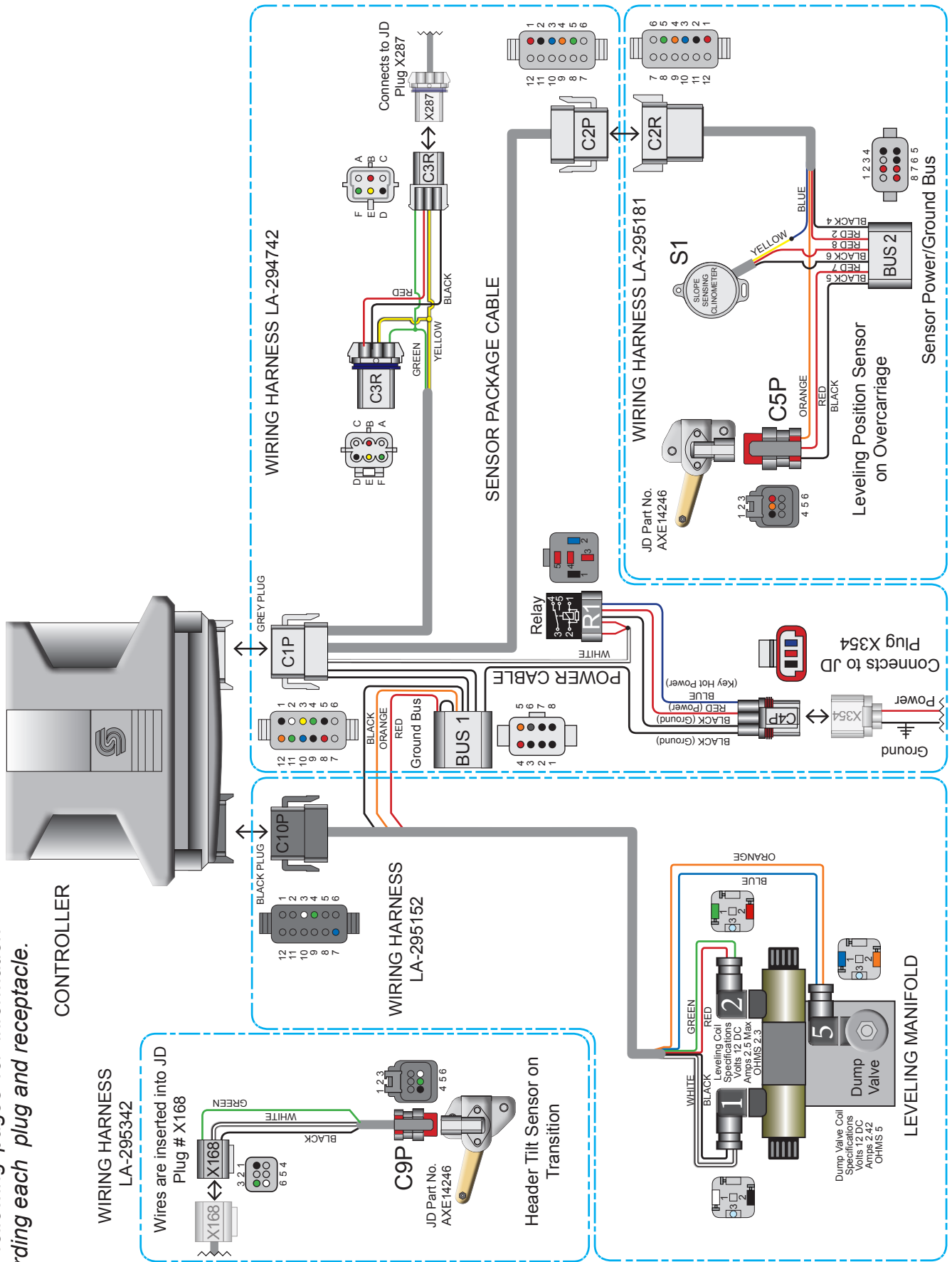

C1P

Location - Controller

PIN	COLOR	FUNCTION	To
1	BLACK	Ground	Bus 1 pin 8
2	WHITE	Power (Keyed)	R1 pin 4,5
3	YELLOW	CAN High	C3R pin 5
4	GREEN	CAN Low	C3R pin 6
5	BLACK	Ground	C3R pin 4
6	-		
7	-		
8	RED	Sensor Power	C2P pin 1
9	BLACK	Sensor Ground	C2P pin 2
10	BLUE	Left/Right Clinometer	C2P pin 3
11	GREEN	Fore/Aft Clinometer	C2P pin 5
12	ORANGE	OC Potentionmeter	C2P pin 4

C2P

Location - Overcarriage

PIN	COLOR	FUNCTION	To
1	RED	Sensor Power	C1P pin 8
2	BLACK	Sensor Ground	C1P pin 9
3	BLUE	Left/Right Clinometer	C1P pin 10
4	GREEN	Fore/Aft Clinometer	C1P pin 11
5	ORANGE	OC Potentionmeter	C1P pin 12
6	-		
7	-		
8	-		
9	-		
10	-		
11	-		
12	-		

C2R

Location - Overcarriage

PIN	COLOR	FUNCTION	To
1	RED	Sensor Power	Bus 2 pin 2
2	BLACK	Sensor Ground	Bus 2 pin 4
3	BLUE	Left/Right Clinometer	S1 Yellow
4	GREEN	Fore/Aft Clinometer	S2 Yellow
5	ORANGE	OC Potentionmeter	C5P pin 2
6	-		
7	-		
8	-		
9	-		
10	-		
11	-		
12	-		

Bus 1

Location - Below Controller

PIN	COLOR	FUNCTION	To
1	BLACK	Combine Ground	C4P pin 3
2	BLACK	Ground Jumper	Bus 1 pin 3
3	BLACK	Ground Jumper	Bus 1 pin 2
4	BLACK	Can Ground	C1P pin 5
5	ORANGE	Manifold Ground	C6R pin 5
6	BLACK	Manifold Ground	C6R pin 3
7	RED	Manifold Ground	C6R pin 1
8	BLACK	Controller Ground	C1P pin 1

C4P

Location - Engine Compartment

PIN	COLOR	FUNCTION	To
1	BLUE	Key Power	R1 pin 2
2	RED	Power	R1 pin 3
3	BLACK	Ground	R1 pin 1
3	BLACK	Ground	Bus 1 pin 1

R1

Location - Engine Compartment

PIN	COLOR	FUNCTION	To
1	BLACK	Ground	C4P pin 3
2	BLUE	Key Power	C4P pin 1
3	RED	Power In	C4P pin 2
4	RED	Not Used	C1P pin 2
5	RED	Power Out	C1P pin 2

Bus 2

Location - Overcarriage

PIN	COLOR	FUNCTION	To
1	-		
2	RED	Sensor Power	C2R Pin 1
3	-		
4	BLACK	Sensor Ground	C2R Pin 2
5	BLACK	Sensor Ground	C5P pin 1
6	BLACK	Sensor Ground	S1 Black
7	RED	Sensor Power	C5P pin 3
8	RED	Sensor Power	S1 Red

C5P

Location - Overcarriage

PIN	COLOR	FUNCTION	To
1	BLACK	Sensor Ground	Bus 2 pin 5
2	ORANGE	OC Potentionmeter	C2R pin 4
3	RED	Sensor Power	Bus 2 pin 7
4	-		
5	-		
6	-		

C3R

Location - Below Controller

PIN	COLOR	FUNCTION	To
A	-		
B	RED	CAN Power	C3R pin 2
C	-		
E	Black 2	CAN Ground	C3R pin 4
F	Yellow	CAN High	C1P pin 3
G	Green 2	CAN Low	C1P pin 4

C9P

Location - Right side of Transition

PIN	COLOR	FUNCTION	To
1	-		
2	-		
3	-		
4	BLACK	Sensor Ground	X168 pin 1
5	GREEN	TA Potentionmeter	X168 pin 3
6	WHITE	Sensor Power	X168 pin 6

X168

Location - Top of Feeder House

PIN	COLOR	FUNCTION	To
1	BLACK	Sensor Ground	C9P pin 4
2	-		
3	GREEN	TA Sensor Output	C9p pin 5
4	-		
5	-		
6	WHITE	Sensor Power	C9P pin 6

C10P

Location - Below Controller

PIN	COLOR	FUNCTION	To
1	-		
2	-		
3	WHITE	#1 Valve Power	C6R pin 6
4	GREEN	#2 Valve Power	C6R pin 2
5	-		
6	-		
7	BLUE	#5 Valve Power	C6R pin 4
8	-		
9	-		
10	-		
11	-		
12	-		

C1P

Location - Controller

PIN	COLOR	FUNCTION	To
1	BLACK	Ground	Bus 1 pin 8
2	WHITE	Power (Keyed)	R1 pin 4,5
3	YELLOW	CAN High	C3R pin 5
4	GREEN	CAN Low	C3R pin 6
5	BLACK	Ground	C3R pin 4
6	-		
7	-		
8	RED	Sensor Power	C2P pin 1
9	BLACK	Sensor Ground	C2P pin 2
10	BLUE	Left/Right Clinometer	C2P pin 3
11	GREEN	Fore/Aft Clinometer	C2P pin 5
12	ORANGE	OC Potentionmeter	C2P pin 4

C2P

Location - Overcarriage

PIN	COLOR	FUNCTION	To
1	RED	Sensor Power	C1P pin 8
2	BLACK	Sensor Ground	C1P pin 9
3	BLUE	Left/Right Clinometer	C1P pin 10
4	GREEN	Fore/Aft Clinometer	C1P pin 11
5	ORANGE	OC Potentionmeter	C1P pin 12
6	-		
7	-		
8	-		
9	-		
10	-		
11	-		
12	-		

C2R

Location - Overcarriage

PIN	COLOR	FUNCTION	To
1	RED	Sensor Power	Bus 2 pin 2
2	BLACK	Sensor Ground	Bus 2 pin 4
3	BLUE	Left/Right Clinometer	S1 Yellow
4	GREEN	Not Used For Sidehill	
5	ORANGE	OC Potentionmeter	C5P pin 2
6	-		
7	-		
8	-		
9	-		
10	-		
11	-		
12	-		

Bus 1

Location - Below Controller

PIN	COLOR	FUNCTION	To
1	BLACK	Combine Ground	C4P pin 3
2	BLACK	Ground Jumper	Bus 1 pin 3
3	BLACK	Ground Jumper	Bus 1 pin 2
4	BLACK	Can Ground	C1P pin 5
5	-		
6	BLACK	Manifold Ground	C6R pin 3
7	RED	Manifold Ground	C6R pin 1
8	BLACK	Controller Ground	C1P pin 1

C4P

Location - Engine Compartment

PIN	COLOR	FUNCTION	To
1	BLUE	Key Power	R1 pin 2
2	RED	Power	R1 pin 3
3	BLACK	Ground	R1 pin 1
3	BLACK	Ground	Bus 1 pin 1

R1

Location - Engine Compartment

PIN	COLOR	FUNCTION	To
1	BLACK	Ground	C4P pin 3
2	BLUE	Key Power	C4P pin 1
3	RED	Power In	C4P pin 2
4	RED	Not Used	C1P pin 2
5	RED	Power Out	C1P pin 2

Bus 2

Location - Overcarriage

PIN	COLOR	FUNCTION	To
1	-		
2	RED	Sensor Power	C2R Pin 1
3	-		
4	BLACK	Sensor Ground	C2R Pin 2
5	BLACK	Sensor Ground	C5P pin 1
6	BLACK	Sensor Ground	S1 Black
7	RED	Sensor Power	C5P pin 3
8	RED	Sensor Power	S1 Red

C5P

Location - Overcarriage

PIN	COLOR	FUNCTION	To
1	BLACK	Sensor Ground	Bus 2 pin 5
2	ORANGE	OC Potentionmeter	C2R pin 4
3	RED	Sensor Power	Bus 2 pin 7
4	-		
5	-		
6	-		

C3R

Location - Below Controller

PIN	COLOR	FUNCTION	To
A	-		
B	RED	CAN Power	C3R pin 2
C	-		
E	Black 2	CAN Ground	C3R pin 4
F	Yellow	CAN High	C1P pin 3
G	Green 2	CAN Low	C1P pin 4

C9P

Location - Right side of Transition

PIN	COLOR	FUNCTION	To
1	-		
2	-		
3	-		
4	BLACK	Sensor Ground	X168 pin 1
5	GREEN	TA Potentionmeter	C7P pin 1
6	WHITE	Sensor Power	X168 pin 6

X168

Location - Top of Feeder House

PIN	COLOR	FUNCTION	To
1	BLACK	Sensor Ground	C9P pin 4
2	-		
3	ORANGE	TA Sensor Output	C7R pin 2
4	-		
5	-		
6	WHITE	Sensor Power	C9P pin 6

C10P

Location - Below Controller

PIN	COLOR	FUNCTION	To
1	-		
2	-		
3	WHITE	#1 Valve Power	C6R pin 6
4	GREEN	#2 Valve Power	C6R pin 2
5	-		
6	-		
7	-		
8	-		
9	-		
10	-		
11	-		
12	-		

JS9010 and JH9010 Header Trim Electrical Schematic
 SN 13001-13999
 For Combines Equipped with Hillco Header Tilt Valve

WIRING HARNESS LA-296221

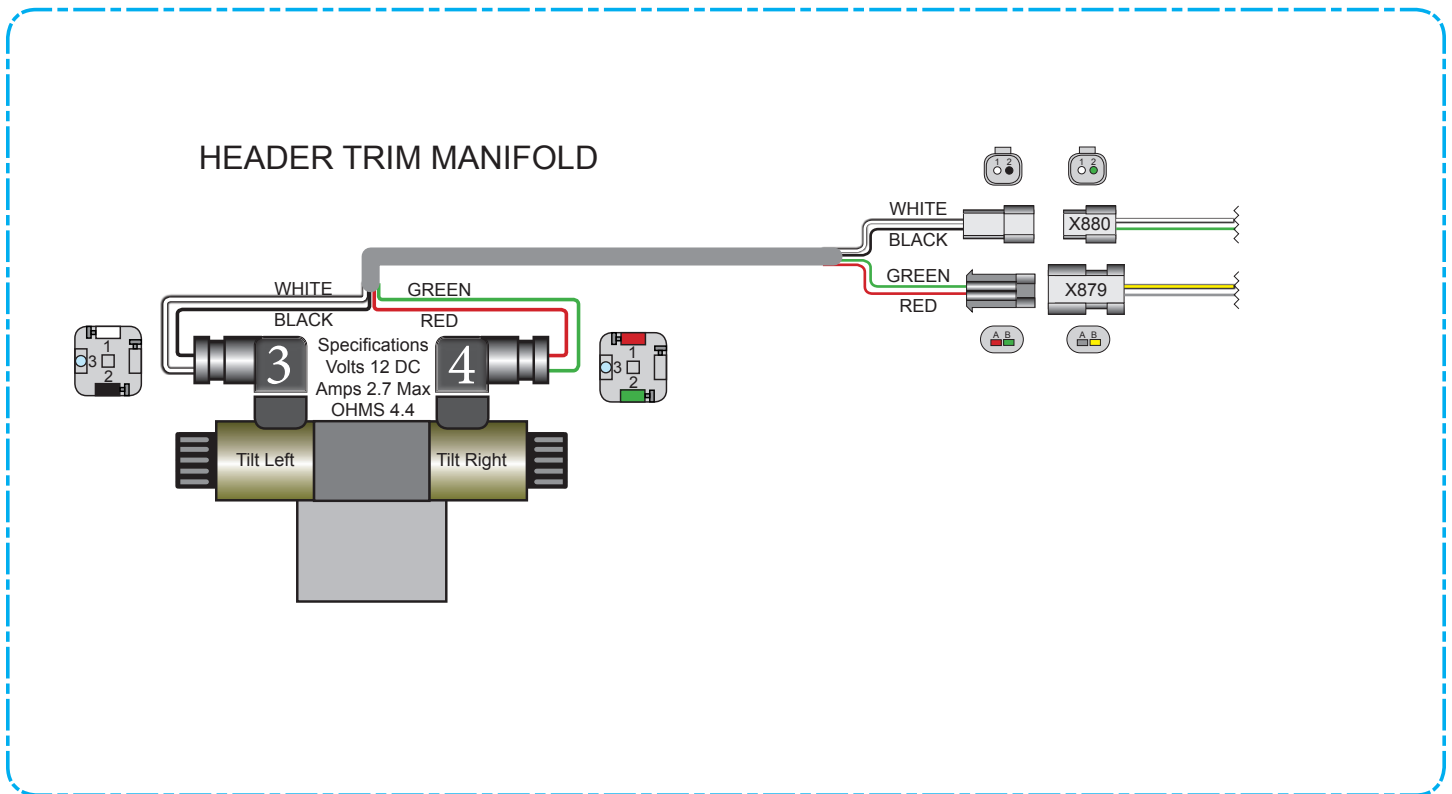

JOHN DEERE PLUG X879
 LOCATION: Left side of Feederhouse

PIN	COLOR	FUNCTION	To
1	WHITE	Trim Left Power	Coil #3 Pin 1
2	BLACK	Trim Left Ground	Coil #3 Pin 2

JOHN DEERE PLUG X880
 LOCATION: Left side of Feederhouse

PIN	COLOR	FUNCTION	To
A	RED	Trim Right Ground	Coil #4 Pin 1
B	GREEN	Trim Right Power	Coil #4 Pin 2

For JS9010 Header Trim Electrical Schematic refer to the John Deere Combine Operator's Manual.

JS5010, JS7010 & JH7010 Header Trim Electrical Schematic
SN 13001-13999

WIRING HARNESS LA-260222

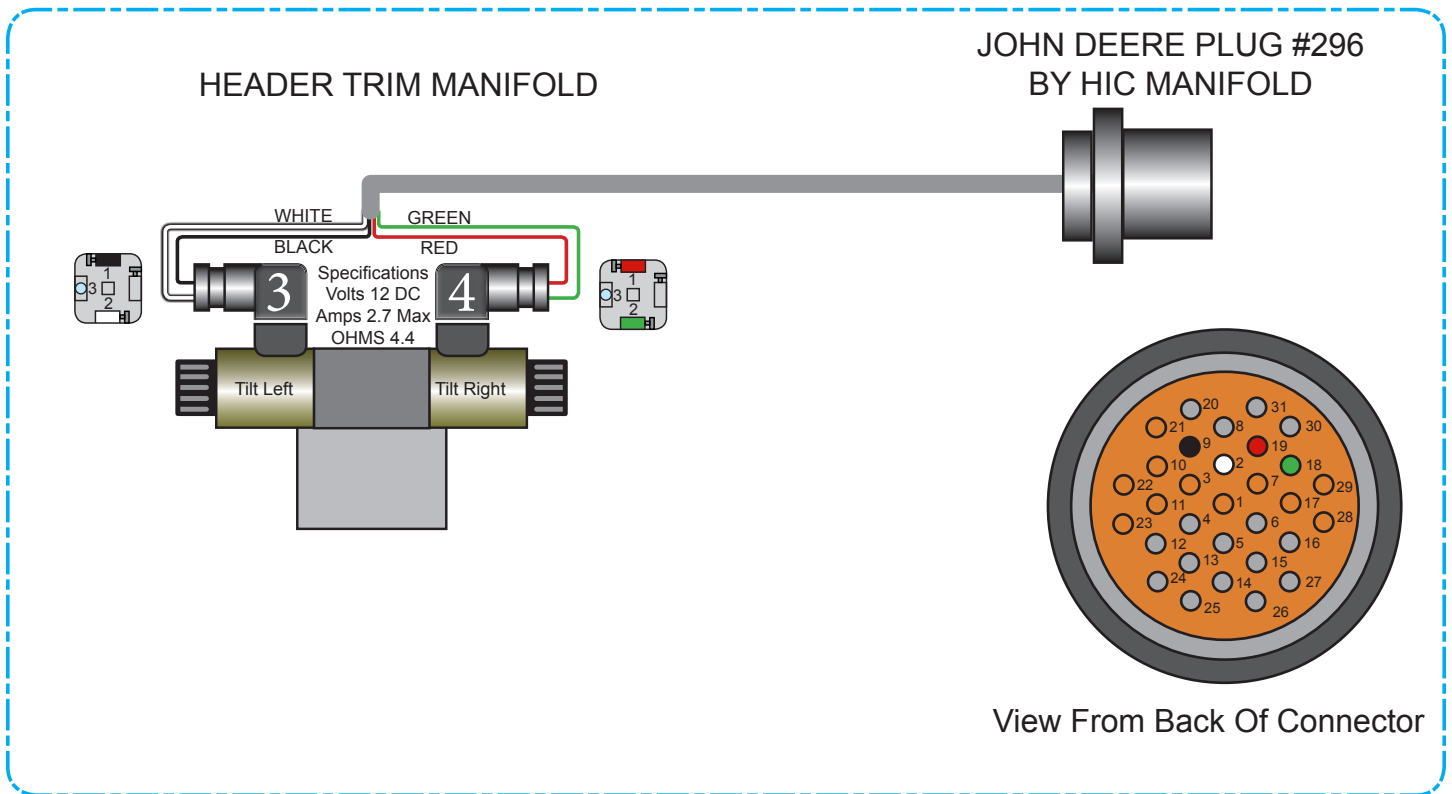

JOHN DEERE PLUG #296
Location: Left Side of Rotor

PIN	COLOR	FUNCTION	To
2	WHITE	Trim Left Power	Coil #3 Pin 2
9	BLACK	Trim Left Ground	Coil #3 Pin 1
18	GREEN	Trim Right Power	Coil #4 Pin 2
19	RED	Trim Right Ground	Coil #4 Pin 1

JS9010 & JH9010 Hydraulic Circuit Schematic

For John Deere S680 & S690 Combines with Contour Master
HILLCO Serial Number 13001 thru 13999

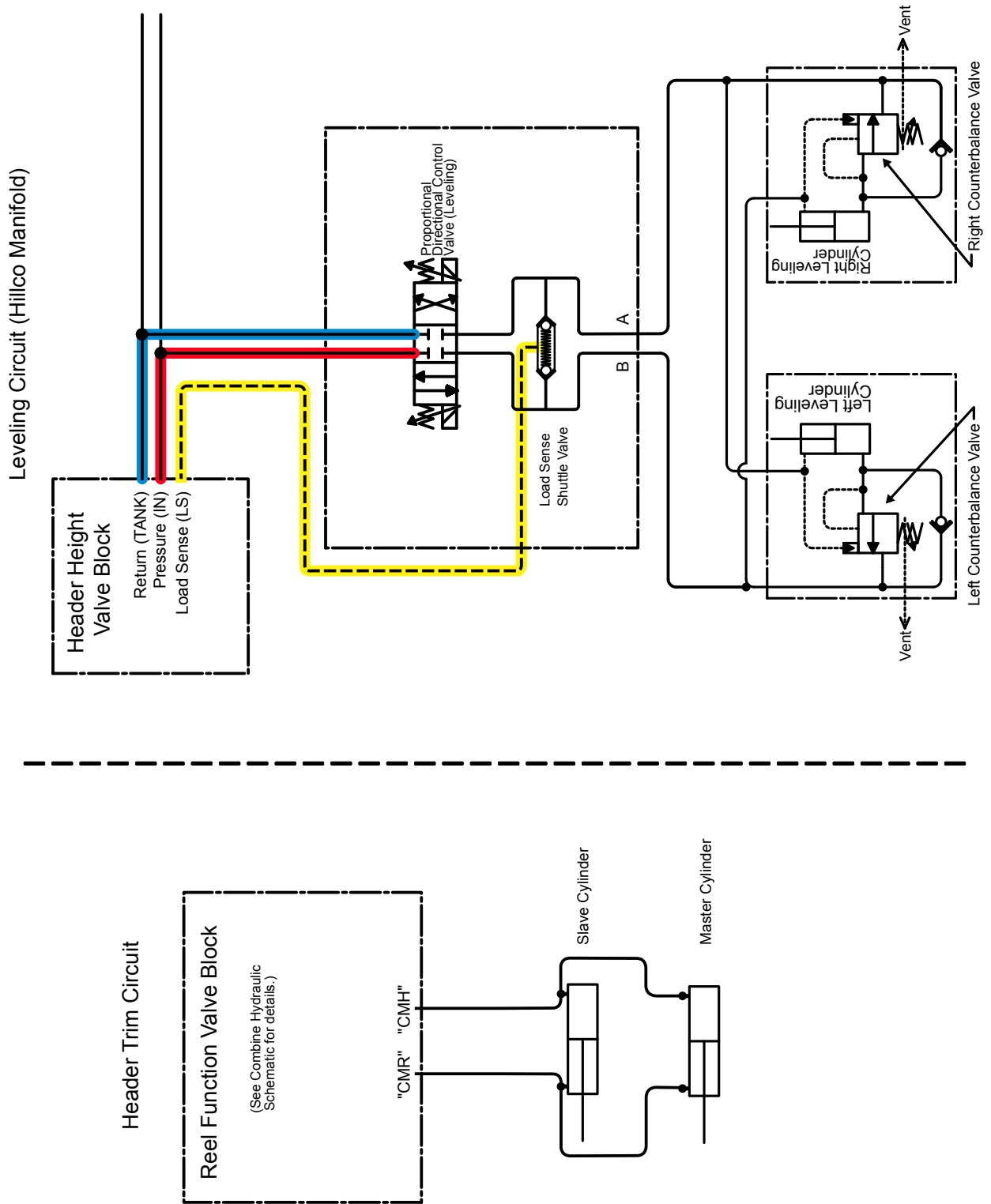

JS9010 & JH9010 Hydraulic Circuit Schematic

For John Deere S680 & S690 Combines without Contour Master

HILLCO Serial Number 13001 thru 13999

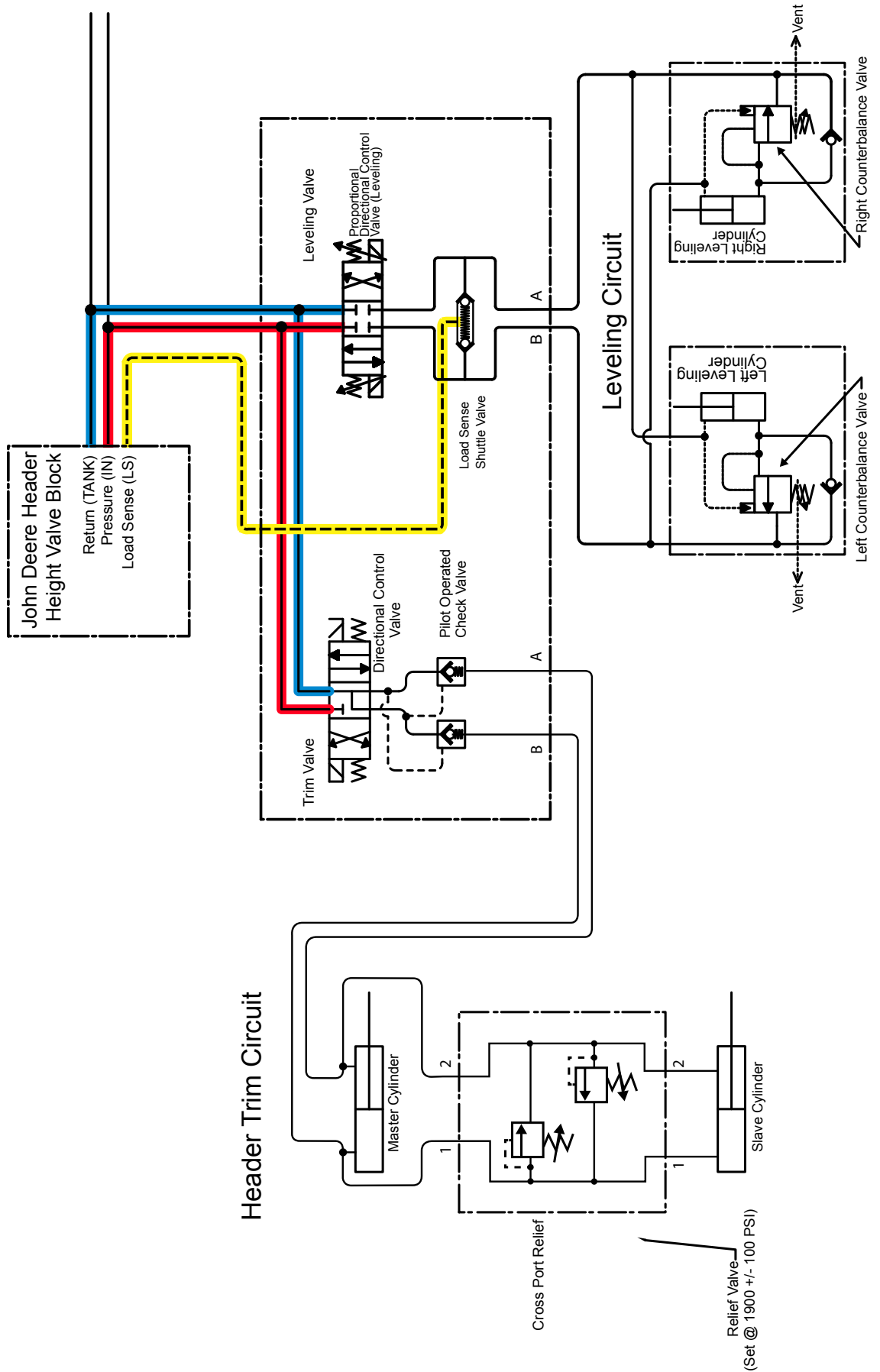

JS5010, JS7010 & JH7010 Standard (Gear Pump) Hydraulic Circuit Schematic

For John Deere S550, S660, & S670 Combines:
Hillco Serial Number 13001-13999

Header Trim Circuit

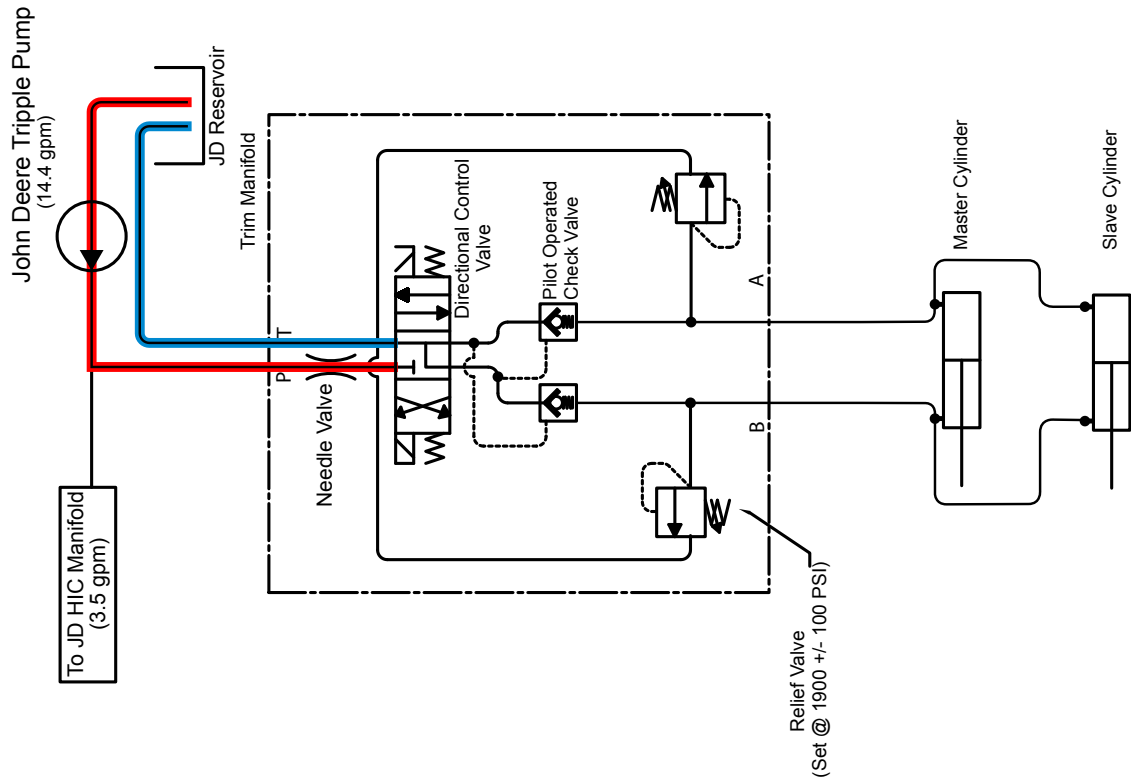

Leveling Circuit

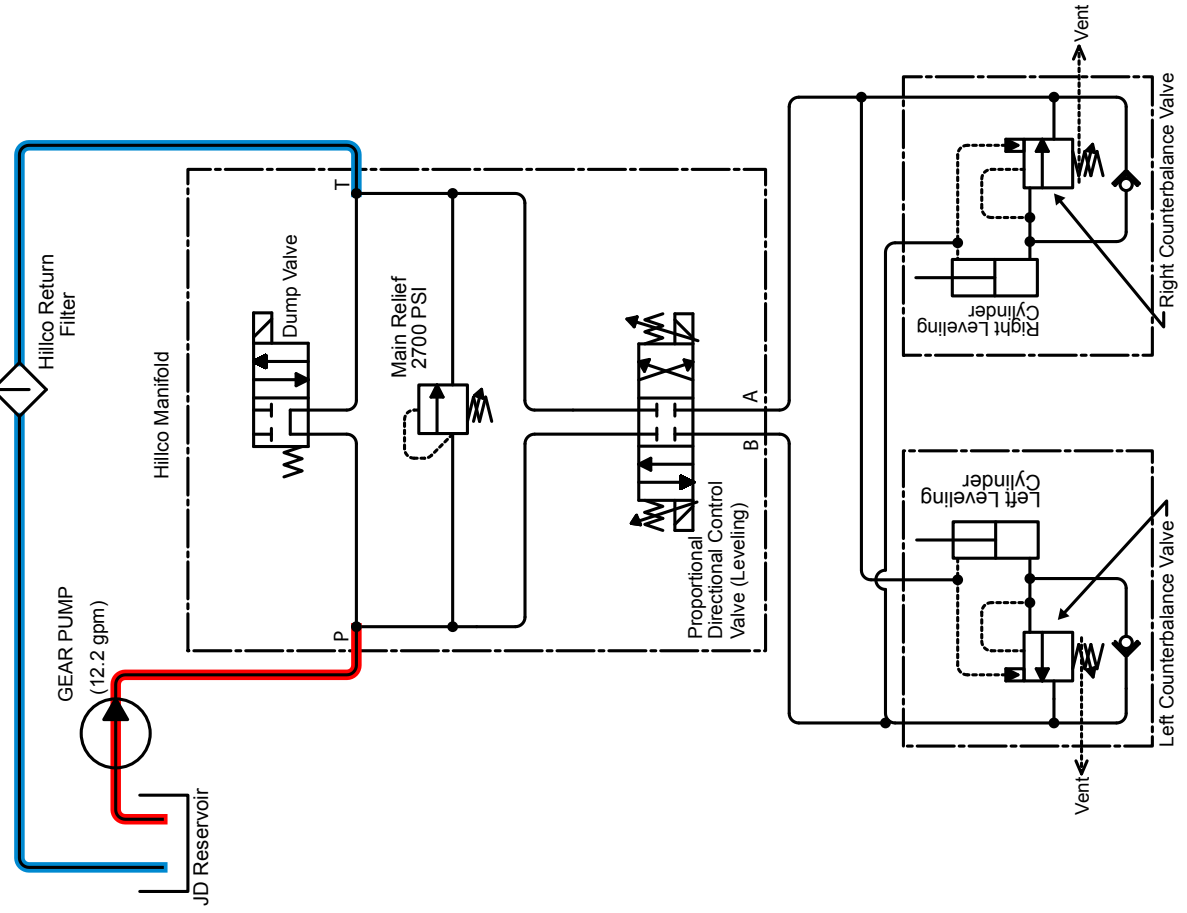

Notes