

Model CH9010 Hillco Leveling System
For Serial Numbers CH9010-12001 thru CH9010-12999



Model CH9010 Hillside Leveling System Parts Manual

SN CH9010-12001 thru CH9010-12999
For Case-IH 7230, 8230, and 9230
Combines

D-120623CMA01



CH9010 Hillside Leveling System

For Case-IH 7230, 8230, and 9230 Combines

Table of Contents

General Information	3
Serial Number Location	3
Text and Illustrations	3
Abbreviations	3
Right and left Identification	3
Part Orders	3
TRANSITION	4
Transition Fasteners	6
Radial Pin Slip Clutch	8
DRIVE WHEEL	9
CARRIAGE	10
Carriage Fasteners	12
DROP AXLE	14
LADDER	16
ELECTRICAL	18
Leveling Box	18
Monitor Display	20
Remote Switches	21
Electrical Connectors & Cables	22
HYDRAULICS COMPONENTS	24
Leveling Manifold	26
Hydraulic Hoses	28
Hydraulic Adapters	29
MISCELLANEOUS	30

Contact Information

Hillco Technologies, Inc.
107 1st Avenue
Nezperce, Idaho 83543

Phone 800-937-2461
208-937-2461
Fax 208-937-2280

www.hillcotechnologies.com
email: support@hillcotechnologies.com

GENERAL INFORMATION

SERIAL NUMBER LOCATION

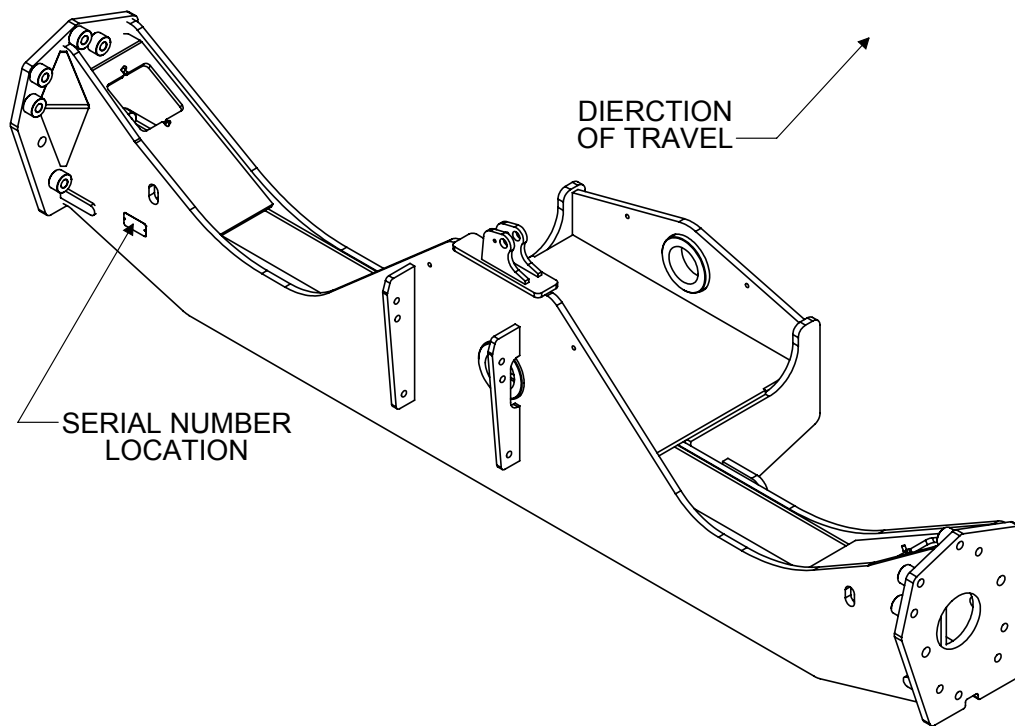

TEXT AND ILLUSTRATIONS

The arrangement of this parts catalog is for easy identification of parts. All parts are illustrated in exploded views in proper relation to each other. Some diagrams refer to other pages for further information. Reference numbers used in the illustrations refer to line numbers in the part lists. The part lists appear to the right or below all diagrams and correspond with those diagrams. Included in the part lists, along with the reference numbers are part numbers, part descriptions and the quantity of the part required per leveling system.

ABBREVIATIONS

SN "Serial Number" refers to the serial number given to each leveling system (by Hillco Technologies), as well as the serial number given to the combine (by the specific combine manufacturer) the leveling system is installed. See above for the leveling system's serial number location. This abbreviation is used interchangeably in both instances. Each Model CH9010 Leveling System uses the following serial number format: CH9010-XXXX (sequential numbers).

ASM "Assembly" refers to a whole grouping of parts (shown in the diagram corresponding with the page where "ASM" is shown unless otherwise noted). Some assemblies have parts that are sold separately, however some must be purchased as a single unit. Hillco Product Specialists will be able to assist you with any questions.

NS "Not Shown" refers to a part that is not depicted in the illustration.

RIGHT AND LEFT IDENTIFICATION

The reference to right-hand and left-hand in this catalog is identified by the operator sitting in the operator's seat, looking toward the front of the machine (in normal forward travel).

PART ORDERS

Orders must specify product model, serial number, correct part number, complete description, quantity required, method of shipment, shipping address, and billing address.

Model CH9010 Hillco Leveling System
For Serial Numbers CH9010-12001 thru CH9010-12999

TRANSITION COMPONENTS				
REF.	PART NO.	QTY.	PART NAME	NOTES
1	LW-251516	1	TA ASM	
2	LW-251625	1	TT ASM	
3	LA-255141	1	TM MOUNT ASM, ROD	
4	HC-147491	1	CYLINDER, SLAVE	SEE HYDRAULIC PAGE 24
5	LA-229071	2	TM PIN ASM, TRIM CYLINDER	
6	LTP-241721	1	BUSHING, PIVOT	
7	MC-150741	1	TM COLLAR, PIVOT	
8	LA-270261	1	TM ASM, LH HEADER LATCH	
9	LA-270251	1	TA ASM, RH HEADER LATCH	
10	LA-270272	1	TM ASM, HEADER LATCH CROSS SHAFT	
11	LM-270191	1	TM ARM, RH LOWER PIVOT	
12	LM-270201	1	TM LINKAGE, LH HEADER LOCK	
13	LM-270211	1	TM LINKAGE, RH HEADER LOCK	
14	LA-253621	1	TM ASM, HYDRAULIC COUPLER	
15	LM-251791	2	TM SPACER, EYEBOLT	
16	LP-249871	2	TM UHMW, BACKING	
17	LM-255182	1	TM PLATE, WEAR BOTTOM	
18	LM-255192	1	TM PLATE, WEAR LH	
19	LM-255202	1	TM PLATE, WEAR RH	
20	LM-255121	2	TM PLATE, BACKING	
BEATER SHAFT				
21	LA-251632	1	TB ASM, SHAFT	
22	LB-286321	2	TB PADDLE, METAL	NOT SUITABLE FOR CORN
23	LW-292671	2	TM WLD, BRG PROTECT WALL	
23A	LW-292671	2	TM WLD BEARING PROTECT SHAFT	
24	LS-212701	1	TM KEY, BEATER DRIVE; 3/8 X 3/8	
25	MC-135511	1	HUB, SPLIT TAPER 1-7/16	
26	MC-136151	1	SPROCKET, 80P, 14T TAPER BORE	
27	MC-101339	1	FLANGETTES, RND BEARING (PAIR)	
28	MC-100548	2	INSERT, BEARING, 1-7/16	
29	LA-243691	2	TM ASM, INNER FLANGETTE	
30	LP-263111	2	TM SPACER, BEATER BEARING	
NS	LM-213243	1	TM CHAIN, 30 PIN 80P	
NS	MC-142871	1	LINK, CONNECTING, 80P	
NS	MC-142881	1	LINK, OFFSET, 80P	
51	LW-292671	2	TM WLD BEARING PROTECT SHAFT	
TRANSITION THROAT JACK SHAFT				
31	LA-251322	1	TM ASM, JS MOUNT	
32	LM-251771	1	TT SHAFT, JACK	
33	MC-100548	2	INSERT, BEARING, 1-7/16	
34	MC-101339	2	FLANGETTES, RND BEARING (PAIR)	
35	LS-212701	1	TM KEY, JACK SHAFT	
36	MC-135511	1	HUB, SPLIT TAPER 1-7/16	
37	MC-135491	1	SPROCKET, 80P, 11T TAPER BORE	
38	MC-100237	1	SPROCKET, IDLER, 60P, 15T, 5/8B	
39	LM-251881	1	TM SPACER, 60P IDLER SPROCKET	
40	LA-259821	1	RADIAL PIN SLIP CLUTCH	
41	LM-226532	1	TM SPROCKET, RADIAL SLIP CLUTCH	
42	LM-244471	1	TM KEY, RADIAL SLIP CLUTCH	
NS	LP-251783	1	TM CHAIN, 70 PIN 60P	
NS	MC-139361	1	LINK, CONNECTING, 60P	
NS	MC-139371	1	LINK, OFFSET, 60P	
FEEDER HOUSE BEATER DRIVE				
43	MC-101838	1	HUB, POWER LOCK, 1-3/8B	
44	LM-255211	1	TM SPROCKET, POWERLOCK, 18T 60P	
45	LA-263062	1	TM SHIELD ASM, REAR DRIVE INNER	
46	LA-263072	1	TM SHIELD ASM, REAR DRIVE OUTER	
47	LA-275681	1	TM ASM, FRONT SHIELD	
48	LB-293461	1	TM, SHIELD, 80P CHAIN	
OPTIONAL FOR COMBINES HARVESTING LEGUMES (PEAS, LENTILS, GARBANZO BEANS, FLAX)				
49	LM-259861	2	TM PLATE, NARROWING	
OPTIONAL FOR COMBINES HARVESTING GRASS				
NS	LP-262041	2	TM COVER, GRASS	
OPTIONAL FOR COMBINES WITH RUBBER PADDLES				
50	LM-272171	2	TB PLT, METAL BACKING	
51	LM-272181	2	TB PADDLE, RUBBER	

TRANSITION FASTENERS

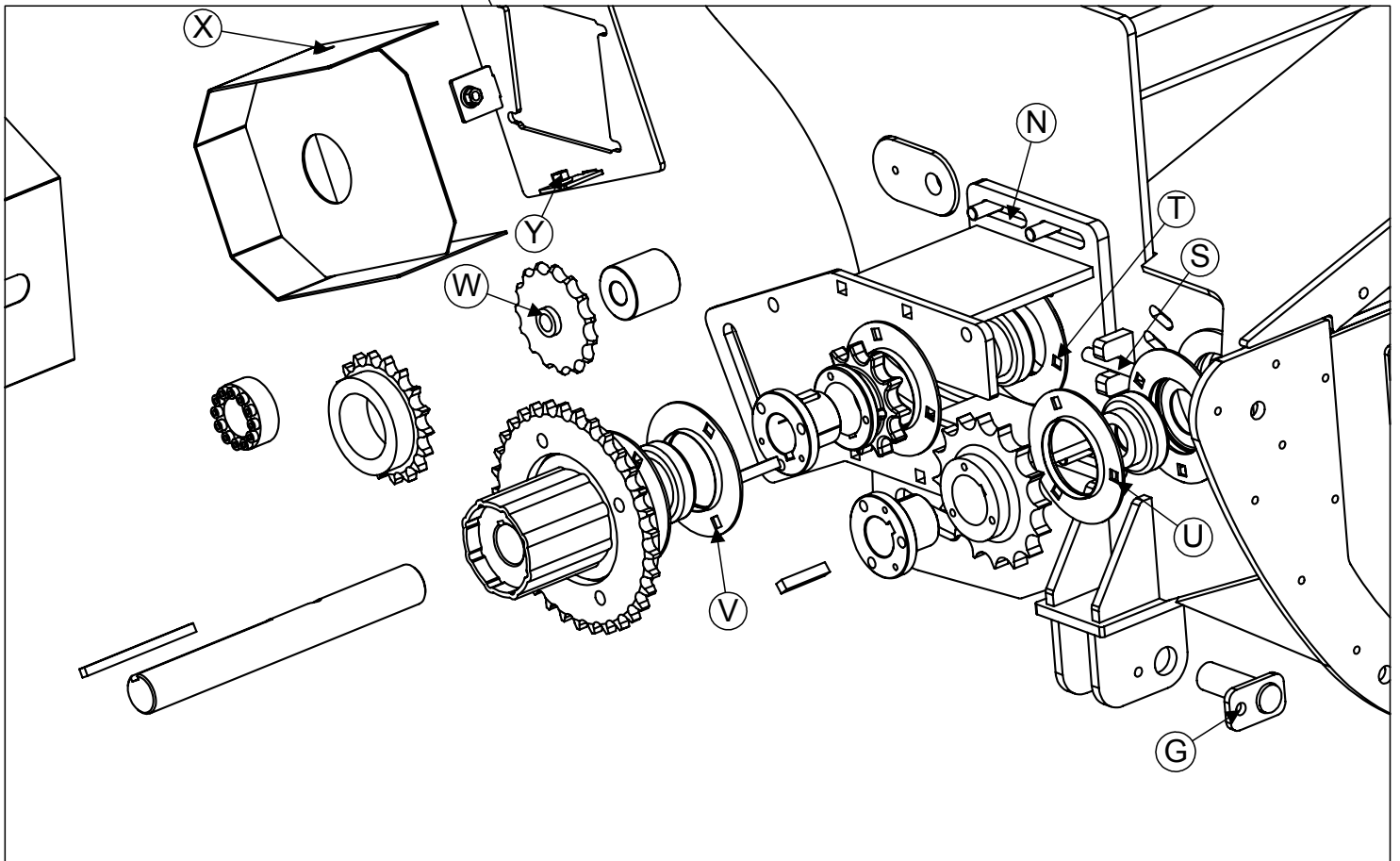
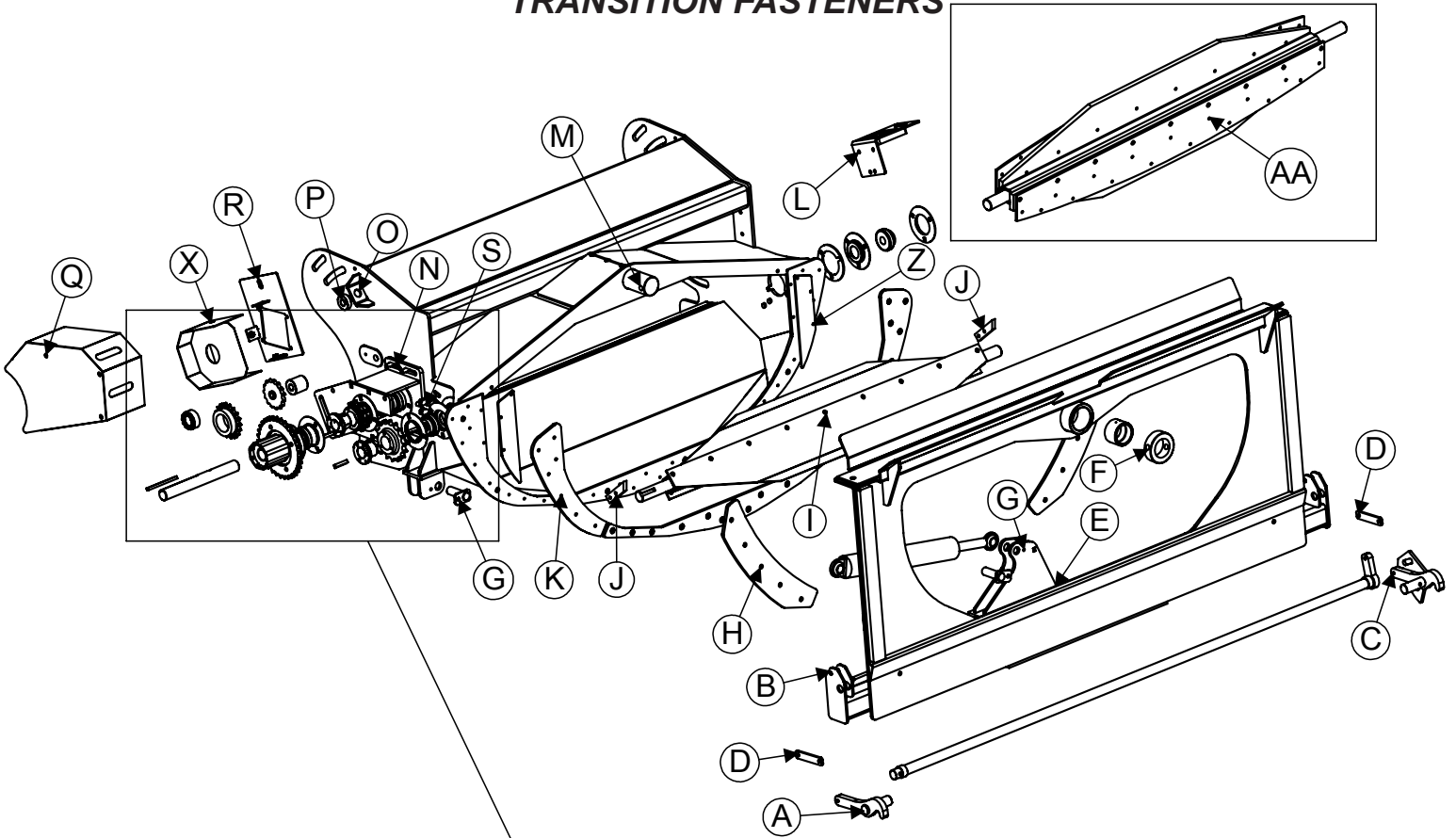

Model CH9010 Hillco Leveling System
For Serial Numbers CH9010-12001 thru CH9010-12999

TRANSITION FASTENERS				
REF.	PART NO.	QTY.	PART NAME	WHERE USED
A	F-PCL-16X32	2	PIN, CLEVIS, 1 X 2	HEADER LOCK ARM
A	F-PCT-03X32	2	PIN, COTTER, 3/16 X 2	HEADER LOCK ARM
B	F-PQR-08X32	2	PIN, QUICK RELEASE	HEADER LOCK ARM
C	F-HCF-10M040E	4	FLHC-10.0 M10 X 1.50 X 40	HEADER LOCK ASM TO ARM
C	F-HNSF-10ME	4	FLHN-10.9 M10 X 1.50 STV	HEADER LOCK ASM TO ARM
D	F-HCF-10M060E	1	FLHC-10.9 M10 X 1.50 X 60 PLT	HEADER LOCK LINKAGE
D	F-HNS-10ME	1	HN-10.9 M10 X 1.50 STOVER PLT	HEADER LOCK LINKAGE
D	F-PR-06X32	2	PIN, ROLL, 3/8 X 2 PLT	HEADER LOCK LINKAGE
D	F-MB-18NR20	6	BUSHING, MACH 18 GA NR, 1-1/4" ID	HEADER LOCK LINKAGE
D	F-MV-18NR24	4	BUSHING, MACH 18 GA NR, 1-1/2" ID	HEADER LOCK LINKAGE
E	F-HC-16M050E	3	HC-10.9 M16 X 2.00 X 50	ROD MNT
E	F-HNS-16ME	3	HN-10.9 M16 X 2.00 STV	ROD MNT
F	F-HC-16M120E	1	HC-10.9 M16 X 2.00 X 120	TT PIVOT PIN COLLAR
F	F-HNS-16ME	1	HN-10.9 M16 X 2.00 STV	TT PIVOT PIN COLLAR
G	F-HCF-10M020E	2	FLHC-10.9 M10 X 1.50 X 20	SLAVE CYLINDER MOUNT PIN
H	F-HCF-12M040E	10	FLHC-10.9 M12 X 1.75 X 40	BACKING PLATES
I	F-HNSF-12ME	9	FLHN-10.9 M12 X 1.75 STV	STEEL PADDLES
I	F-HCF-12M080E	9	FLHC-10.9 M12 X 1.75 X 80	STEEL PADDLES
J	F-HCF-12M020E	4	FLHC-10.0 M12 X 1.75 X 20	BEATER SHAFT STRIPPERS
K	F-FHS-8M016E	29	FHSC-10.9 M8 X 1.25 X 16	TT FACE PLATE
L	F-HCF-10M025E	2	FLHC-10.9 M10 X 1.50 X 25	HDR HYDRAULIC COUPLER MNT
L	F-HNF-10ME	2	FLHN-10.9 M10 X 1.50	HDR HYDRAULIC COUPLER MNT
M	F-MB-14NR40	7	BUSHING, MACH 14 GA, NR, 2-1/2" ID	TT PIVOT PIN
N	F-HNF-12ME	4	FLHN-10.9 M12 X 1.75	TT 80P CHAIN ADJUSTER
O	F-EYB-20M150E	2	EYEBOLT M20 X 2.50 X 150	ANGLE ADJUSTMENT
O	F-HNF-20ME	4	FLHN-10.9 M20 X 2.50	ANGLE ADJUSTMENT
P	F-CB-12C56	2	CARR-GR. 5 3/4-10 X 3-1/2	ANGLE ADJUSTMENT
P	F-HNF-12C	2	FLHN-GR. 5 3/4-10	ANGLE ADJUSTMENT
Q	F-HNF-10ME	12	FLHN-10.9 M10 X 1.50 PLT	MAIN BEATER DRIVE SHIELD
Q	F-HNJ-10MF	3	HN-8.8 M10 X 1.5 JAM PLT	MAIN BEATER DRIVE SHIELD
Q	LM-263021	3	TM ALL THREAD	MAIN DRIVE SHIELD
R	F-HCF-08M025E	4	FLHC-10.9 M8 X 1.25 X 25	REAR TRANSITION DRIVE SHIELD
R	F-HNS-08ME	4	HN-10.9 M8 X 1.25 STV	REAR TRANSITION DRIVE SHIELD
S	F-FWH-08	2	FW 1/2 HD YELLOW	TT 80P CHAIN ADJUSTER
S	F-HNJ-12MF	2	HN-8.8 M12 X 1.75 JAM	TT 80P CHAIN ADJUSTER
T	F-HCF-10M016F	3	FLHC-8.8 M10 X 1.50 X 16	INNER JACKSHAFT BEARING
U	F-CB-10M030F	6	CARR-8.8 M10 X 1.50 X 30	TT BEATER BRNG
U	F-HNF-10MF	6	FLHN-8.8 M10 X 1.50	TT BEATER BRNG
V	F-CB-10M030F	3	CARR-8.8 M10 X 1.50 X 30	OUTER JACKSHAFT BEARING
V	F-HNF-10MF	3	FLHN-8.8 M10 X 1.50	OUTER JACKSHAFT BEARING
W	F-HC-16M110E	1	HC-10.9 M16 X 2.0 X 110	60P IDLER SPROCKET
W	F-HNS-16ME	1	HN-10.9 M16 X 2.0 STV	60P IDLER SPROCKET
W	F-FWH-10	5	FW 5/8 HD	60P IDLER SPROCKET
X	F-HCF-08M020E	6	FLHC- M8 X 1.25 X 20	REAR TRANSITION DRIVE SHIELD
Y	F-HNF-08ME	3	HEX NUT FLANGE, M8 X 1.25	REAR DRIVE SHIELD ASM
Z	F-HNF-16ME	2	HEX NUT FLANGE, M16 X 2	HEADER LATCHING HANDLE
Z	F-HCF-16M045E	2	HEX CAP SCREW M16 X 2 X 45	HEADER LATCHING HANDLE
OPTIONAL FOR COMBINES HARVESTING LEGUMES (PEAS, LENTILS, GARBANZO BEANS, FLAX)				
AA	F-HC-06M020F	6	HC-8.8 M6 X 1.0 X 20	THROAT NARROWING PLATE
AA	F-HNF-06MF	6	FLHN-8.8 M6 X 1.0	THROAT NARROWING PLATE
OPTIONAL FOR COMBINES WITH RUBBER PADDLES				
BB	F-EB-04C20	34	BOLT, ELEVATOR, 1/4-20 X 1-1/4 ZINC PLT	RUBBER PADDLES
BB	F-HNF-04C	34	FLHN 1/4-20, ZINC, SERR, PLT	RUBBER PADDLES

RADIAL PIN SLIP CLUTCH

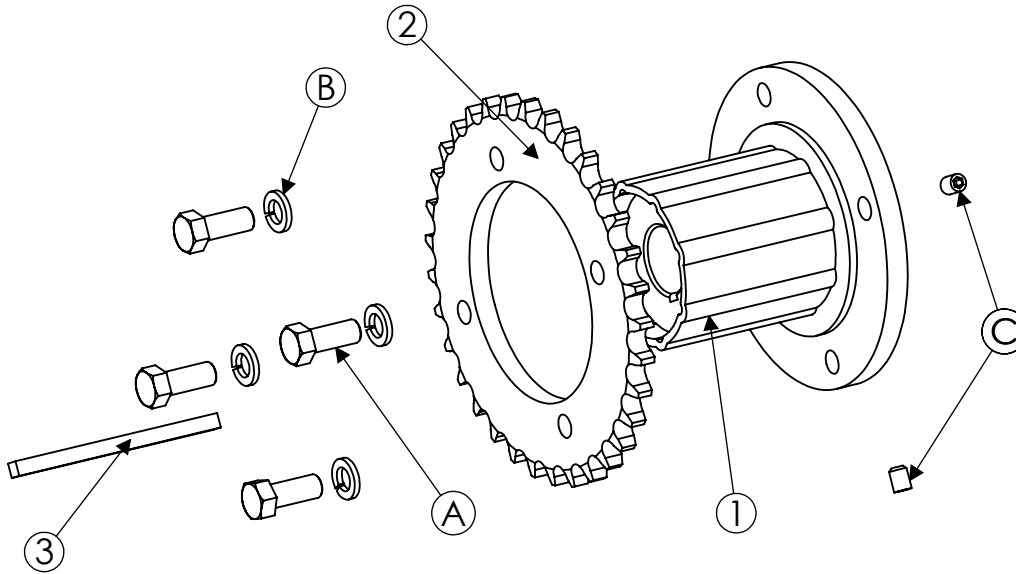

RADIAL PIN SLIP CLUTCH				
REF.	PART NO.	QTY.	PART NAME	NOTES
1	LA-259821	1	RADIAL PIN SLIP CLUTCH	1050 Nm
2	LM-226532	1	TM SPROCKET, RADIAL SLIP CLUTCH	
3	LM-244471	1	TM KEY, RADIAL SLIP CLUTCH	
RADIAL PIN SLIP CLUTCH FASTENERS				
REF.	PART NO.	QTY.	PART NAME	WHERE USED
A	F-HC8-08F20	4	HC8 1/2-20 X 1-1/4	
B	F-LWH-08	4	LW 1/2 HD	
C	F-SSS-06C08	2	SCREW, SOCKET SET 3/8-16 X 1/2	

Model CH9010 Hillco Leveling System
 For Serial Numbers CH9010-12001 thru CH9010-12999

WHEEL

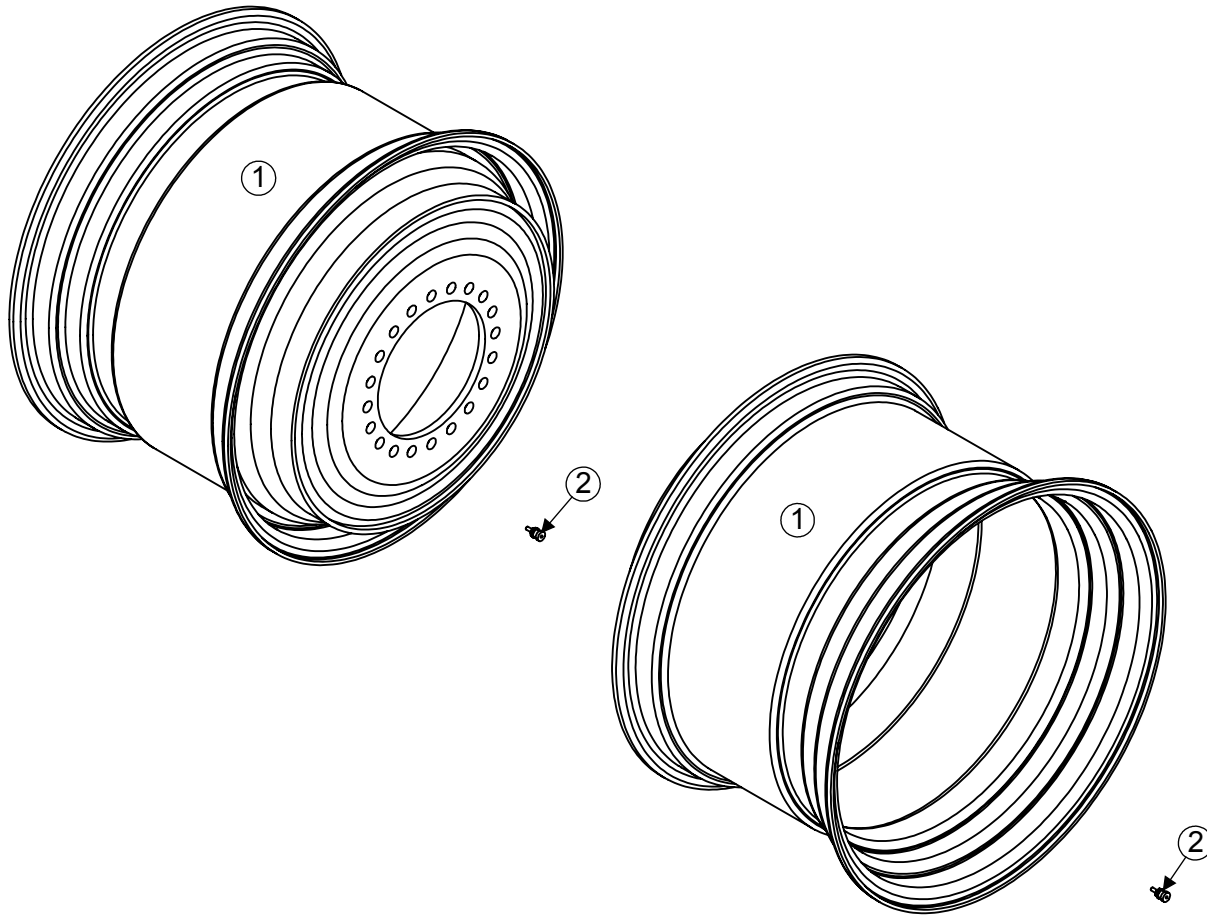

WHEEL COMPONENTS					
REF.	PART NO.	QTY.	PART NAME	NOTES	
1	MC-143121	4	32 X 21 SINGLE PIECE WHEEL		
2	MC-143921	4	VALVE STEM		
WHEEL FASTENERS					
REF.	PART NO.	QTY.	PART NAME	NOTES	
NS	N/A	20	BOLT	CASE P/N 87283525	
NS	N/A	10	SPACER PLATE	CASE P/N 87253501	
NS	N/A	20	NUT	CASE P/N 336845	

Model CH9010 Hillco Leveling System
For Serial Numbers CH9010-12001 thru CH9010-12999

CARRIAGE

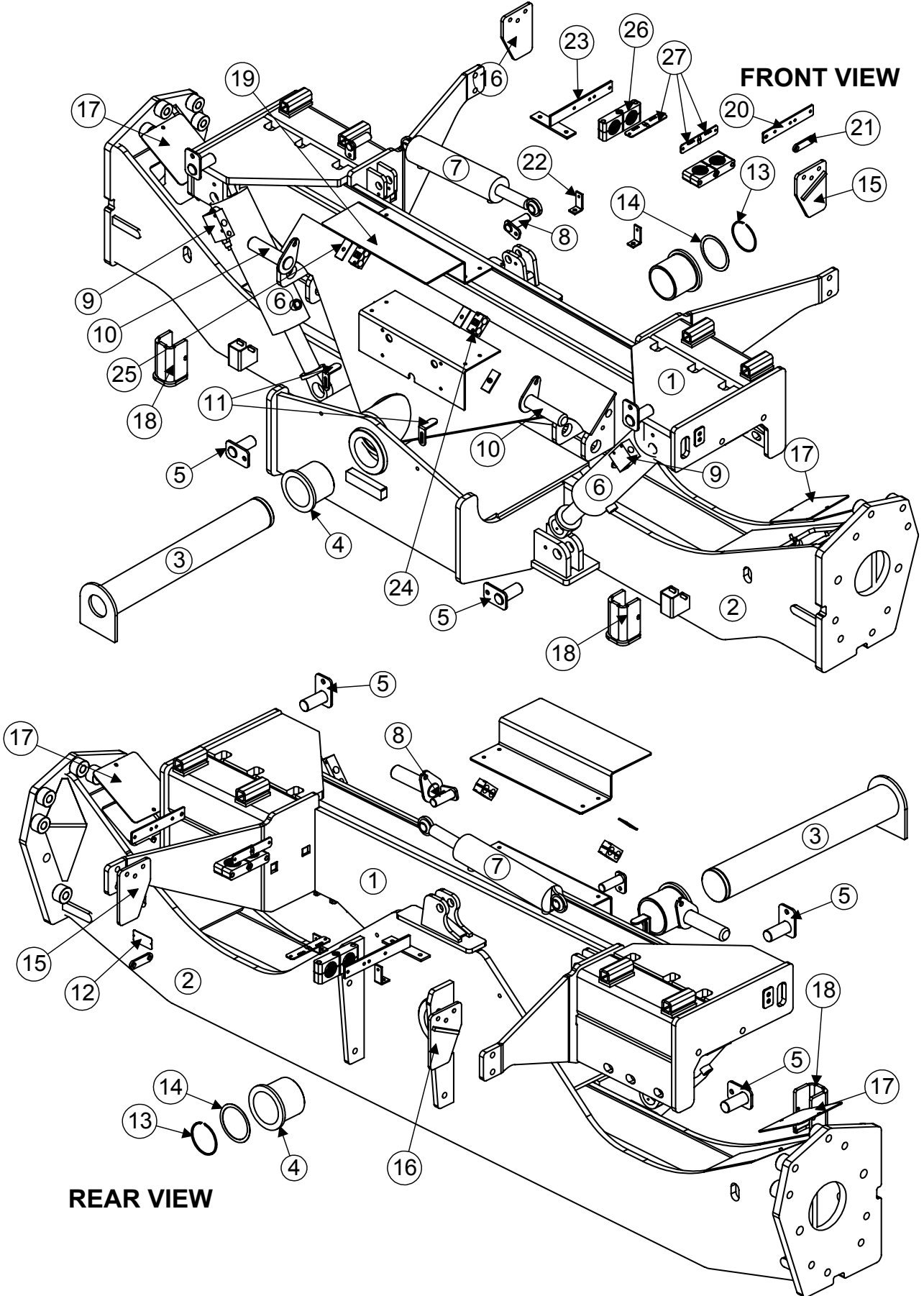

Model CH9010 Hillco Leveling System
For Serial Numbers CH9010-12001 thru CH9010-12999

CARRIAGE COMPONENTS				
REF.	PART NO.	QTY.	PART NAME	NOTES
1	LW-251492	1	OVERCARRIAGE ASM	
2	LA-251531	1	UNDERCARRIAGE ASM	
3	LA-247481	1	CM ASM, MAIN PVT PIN	
4	LP-247961	2	CM BUSHING, PIVOT	
5	LA-230551	4	CM PIN ASM, MAIN CYLINDER	
6	HC-147521	2	CYLINDER, MAIN	SEE HYDRAULICS PAGE 24
7	HC-147501	1	CYLINDER, MASTER	SEE HYDRAULICS PAGE 24
8	LA-229071	2	TM PIN ASM, TRIM CYLINDER	
9	HC-139151	2	VALVE, 3-PORT COUNTERBALANCE	SEE HYDRAULICS PAGE 24
10	LM-255301	2	CM PIN, HEADER LIFT CYLINDER	
11	LP-251551	2	EM PLATE, LIMIT STOP	
12	LA-255951	1	PLATE, SERIAL NUMBER	
13	MC-138651	1	SNAP RING 4"	
14	MC-138641	1-4	WASHER, 4.016" ID X 4.764" OD X .48	
15	LA-251471	1	CM ASM, LEFT SWING ARM MOUNT	
16	LA-251481	1	CM ASM, RIGHT SWING ARM MOUNT	
17	LP-251461	2	CM PLATE, FINAL BOLT COVER	
18	LW-293711	2	CM WLD, CYLINDER STOP	
19	LB-293801	1	EM PLATE, BOX COVER	
NS	LP-285102	1	HYDRO HOSE PULL	PREVENTS HYDRAULIC HOSES FROM RUBBING ON FAN
NS	MC-137501	-	WASHER, QUICK REPAIR 2"	OPTIONAL -- SAFETY STOP -- QTY. AS NEEDED
NS	MC-137251	-	COLLAR, 2-PIECE CLAMPING 2" BORE	OPTIONAL -- SAFETY STOP -- QTY. AS NEEDED
MISCELLANEOUS CARRIAGE COMPONENTS				
REF.	PART NO.	QTY.	PART NAME	NOTES
20	LP-251862	1	HM FLAT, HYDRO HOSE BRACKET	
21	LP-275651	1	HM PLT, HYDRO HOSE SPREADER	
22	LM-251871	2	HM MOUNT, BRAKE LINE	
23	LA-251832	1	HM ASM, HYDRO HOSE BRACKET	
24	HC-140461	2	BEHRINGER TWIN CLAMP .875 DIAMETER	ON OC HOSES BETWEEN CYLINDERS
25	HC-139451	2	BEHRINGER TWIN COVER PLATE (FOR .875)	ON OC HOSES BETWEEN CYLINDERS
26	HC-140641	4	BEHRINGER STD. CLAMP 2" DIAMETER	HYDRO HOSES
27	HC-140651	4	BEHRINGER STD. COVER PLATE	HYDRO HOSES

CARRIAGE FASTENERS

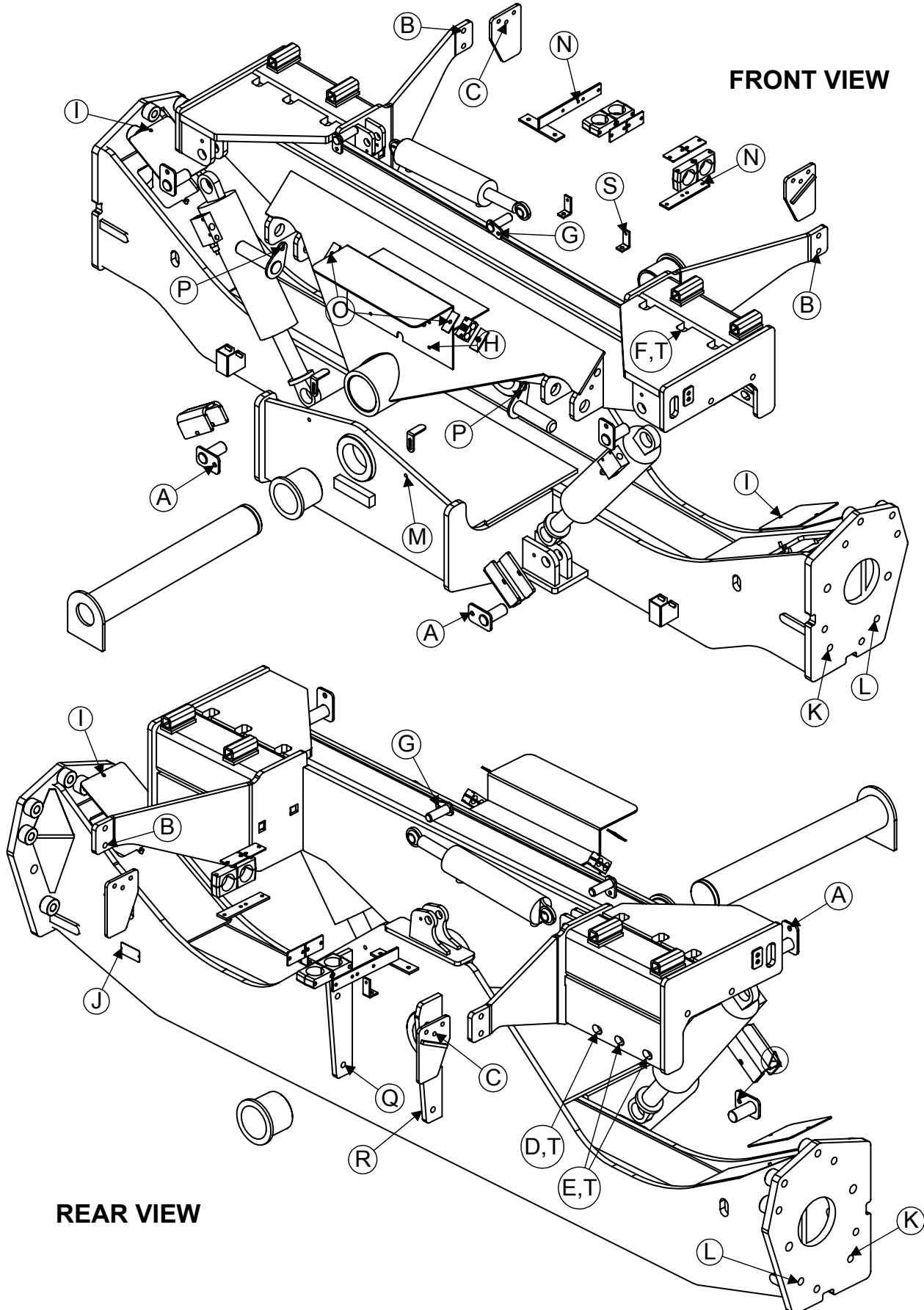

Model CH9010 Hillco Leveling System
For Serial Numbers CH9010-12001 thru CH9010-12999

CARRIAGE FASTENERS				
REF.	PART NO.	QTY.	PART NAME	WHERE USED
A	F-HCF-12M025F	4	FLHC-8.8 M12 X 1.75 X 25	LEVELING CYL MNT PIN
B	F-HC-16M050E	4	HC-10.9 M16 X 2.00 X 50	OC SWING ARM PLATE
B	F-HNS-16ME	4	HN-10.9 M16 X 2.00 STOVER	OC SWING ARM PLATE
C	F-HCF-12M030E	6	FLHC-10.9 M12 X 1.75 X 30	SWING ARM MOUNTING BRACKET
C	F-HNF-12MF	6	FLHN-8.8 M12 X 1.75	SWING ARM MOUNTING BRACKET
D	F-HC-20M070E	2	HC-10.9 M20 X 2.5 X 70	OC REAR MOUNTING PLATE
E	F-HC-20M120	4	HC-10.9 M20 X 2.5 X 120	OC REAR MOUNTING PLATE
F	F-HC-20M280E	6	HC-10.9 M20 X 2.5 X 280	OC BOTTOM MOUNTING PLATE
G	F-HCF-10M020E	2	FLHC-10.9 M10 X 1.50 X 20	MASTER CYL MNT PIN
H	F-HCF-08M020E	8	FLHC-10.9 M8 X 1.25 X 20	ELECTRICAL ASM TO OC
H	F-HNF-08ME	8	FLHN-10.9 M8 X 1.25	ELECTRICAL ASM TO OC
I	F-HNF-8MF	4	FLHN-10.9 M8 X 1.25	UC FINAL BOLT COVER PLATES
J	F-UDS-#7X06	2	SCREW, U-DRIVE #7 X 3/8	SERIAL NUMBER PLATE
K	F-HC-20M090E	16	HC-10.9 M20 X 2.50 X 90	FINAL DRIVES
L	F-SHC-20M090E	2	SHCS- 10.9 M20 X 25 X 90	FINAL DRIVES
M	F-HC-8M040F	2	HC-8.8 M8 X 1.25 X 40	LIMIT SWITCH STOPS
M	F-HNF-08MF	2	FLHN-8.8 M8 X 1.25	LIMIT SWITCH STOPS
N	F-HC-6M090F	8	HC-8.8 M6 X 1.0 X 90	HYDRO HOSE CLAMPS
N	F-HNF-6MF	8	FLHN-8.8 M6 X 1.0	HYDRO HOSE CLAMPS
O	HC-139461	2	BEHRINGER TWIN BOLT (FOR .875) HC5 5/16-18 X 1-3/4	ON OC HOSES BETWEEN CYLINDERS
P	F-HC-12M040E	2	HC-10.9 M12 X 1.75 X 40	HEADER LIFT CYLINDER PINS
P	F-HNS-12ME	2	HN-10.9 M12 X 1.75 STOVER	HEADER LIFT CYLINDER PINS
Q	F-HC-16M050E	6	HC-10.9 M16 X 2.00 X 50	TRANSMISSION MOUNTING
R	MC-141961	--	SHIM, ALIGNMENT, 1/16	TRANSMISSION MOUNTING
R	MC-141971	--	SHIM, ALIGNMENT, 1/32	TRANSMISSION MOUNTING
R	MC-141981	--	SHIM, ALIGNMENT, 1/64	TRANSMISSION MOUNTING
S	F-HC-06M020F	2	HC-8.8 M6 X 1.0 X 20	BRAKE HOSES
S	F-HNF-6MF	2	FLHN-8.8 M6 X 1.0	BRAKE HOSES
T	F-HNS-20ME	16	HN-10.9 M20 X 2.50 STOVER PLT	ALL OC MOUNTING BOLTS
NS	F-HNF-6ME	1	FLHN-10.9 M6 X 1.0 [DIN 6923]	HYDRO HOSE PULL
NS	F-HNF-16ME	1	FLHN-10.9 M16 X 2.0	HYDRO HOSE PULL
NS	F-HNF-10ME	1	FLHN-10.9 M10 X 1.50 [DIN 6923]	HYDRO HOSE PULL
NS	F-HCF-10M020E	1	FLHC-10.9 M10 X 1.50 X 20 [DIN 6921]	HYDRO HOSE PULL

Model CH9010 Hillco Leveling System
For Serial Numbers CH9010-12001 thru CH9010-12999

DROP AXLE

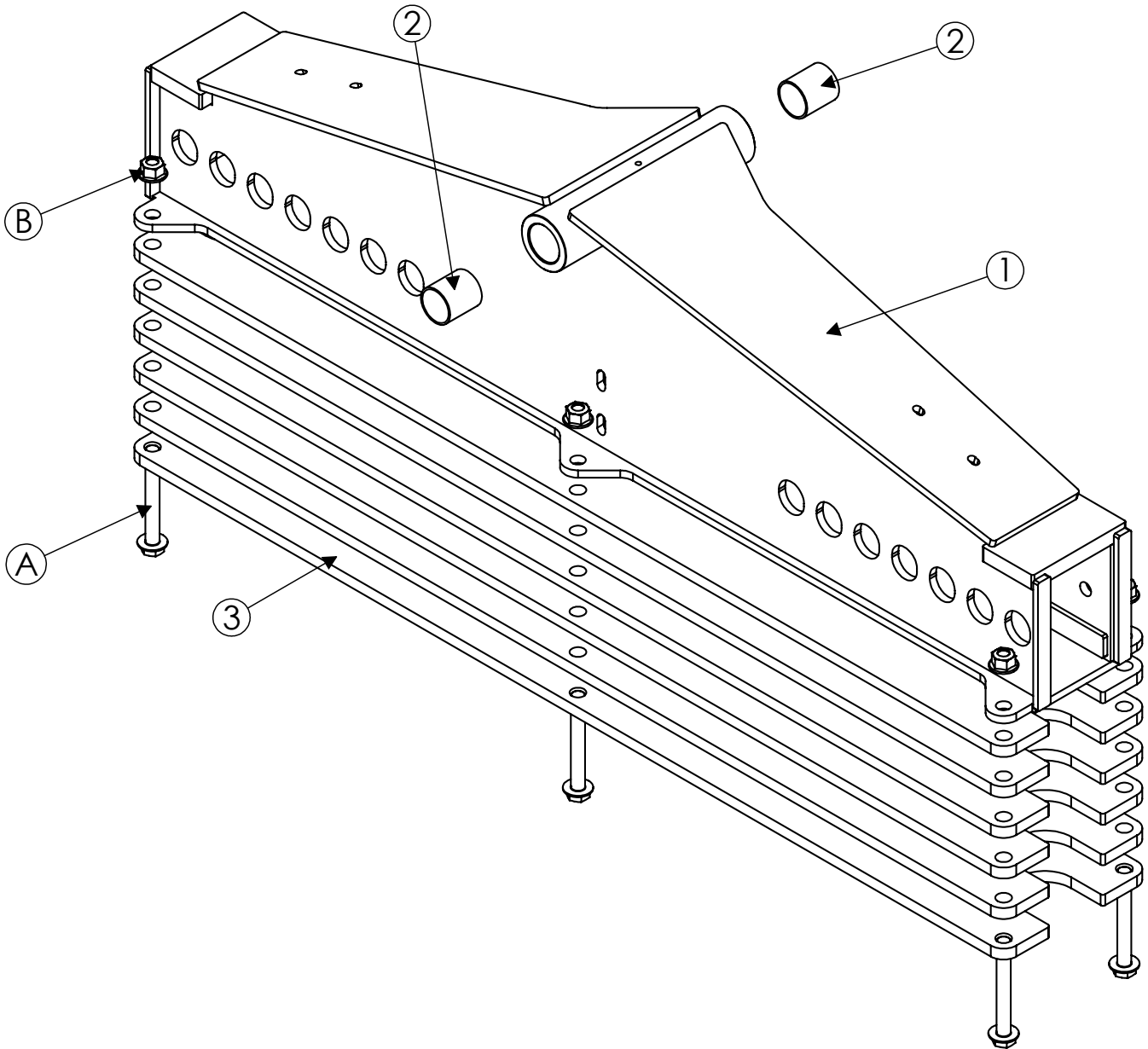

Model CH9010 Hillco Leveling System
For Serial Numbers CH9010-12001 thru CH9010-12999

DROP AXLE COMPONENTS				
REF.	PART NO.	QTY.	PART NAME	NOTES
1	LA-252162	1	DA ASM	
2	MC-140791	2	REAR AXLE PIVOT SLEEVE	CNH P/N 84334438
3	LP-285891	6	WEIGHTS, 160 LBS EACH	OPTIONAL
DROP AXLE WEIGHT OPTIONS				
NS	LA-292091	1	DA OPTION, ZERO WEIGHT	160 LBS EACH
NS	LA-292101	1	DA OPTION, ONE WEIGHT	160 LBS EACH
NS	LA-292111	1	DA OPTION, TWO WEIGHT	160 LBS EACH
NS	LA-292121	1	DA OPTION, THREE WEIGHT	160 LBS EACH
NS	LA-292131	1	DA OPTION, FOUR WEIGHT	160 LBS EACH
NS	LA-292141	1	DA OPTION, FIVE WEIGHT	160 LBS EACH
NS	LA-292151	1	DA OPTION, SIX WEIGHT	160 LBS EACH
NS	LA-292161	1	DA OPTION, SEVEN WEIGHT	160 LBS EACH
NS	LA-292171	1	DA OPTION, EIGHT WEIGHT	160 LBS EACH
NS	LA-292181	1	DA OPTION, NINE WEIGHT	160 LBS EACH
NS	LA-292191	1	DA OPTION, TEN WEIGHT	160 LBS EACH
DROP AXLE FASTENERS				
A	F-HC8-12C56	6	HC8 3/4-10 X 3-1/2	1 WEIGHT BOLT PACKAGE
A	F-HC8-12C56	6	HC8 3/4-10 X 3-1/2	2 WEIGHT BOLT PACKAGE
A	F-HC8-12C72	6	HC8 3/4-10 X 4-1/2	3 WEIGHT BOLT PACKAGE
A	F-HC8-12C88	6	HC8 3/4-10 X 5-1/2	4 WEIGHT BOLT PACKAGE
A	F-HC8-12C96	6	HC8 3/4-10 X 6	5 WEIGHT BOLT PACKAGE
A	F-HC8-12C112	6	HC8 3/4-10 X 7	6 WEIGHT BOLT PACKAGE
A	F-HC8-12C120	6	HC8 3/4-10 X 7-1/2	7 WEIGHT BOLT PACKAGE
A	F-HC8-12C136	6	HC8 3/4-10 X 8-1/2	8 WEIGHT BOLT PACKAGE
A	F-HC8-12C144	6	HC8 3/4-10 X 9	9 WEIGHT BOLT PACKAGE
A	F-HC8-12C160	6	HC8 3/4-10 X 10	10 WEIGHT BOLT PACKAGE
B	F-HNSF-20ME	6	M20X2.5 NUT, FLANGED, METRIC 10.9	ALL WEIGHT BOLT PACKAGES
NS	F-LW-12A	6	LW 3/4 HD	ALL WEIGHT BOLT PACKAGES
NS	F-FWH-12	6	FW 3/4 HD	ALL WEIGHT BOLT PACKAGES
**ALL FASTENERS USED ON THE DROP AXLE ARE ORIGINAL EQUIPMENT				

LADDER

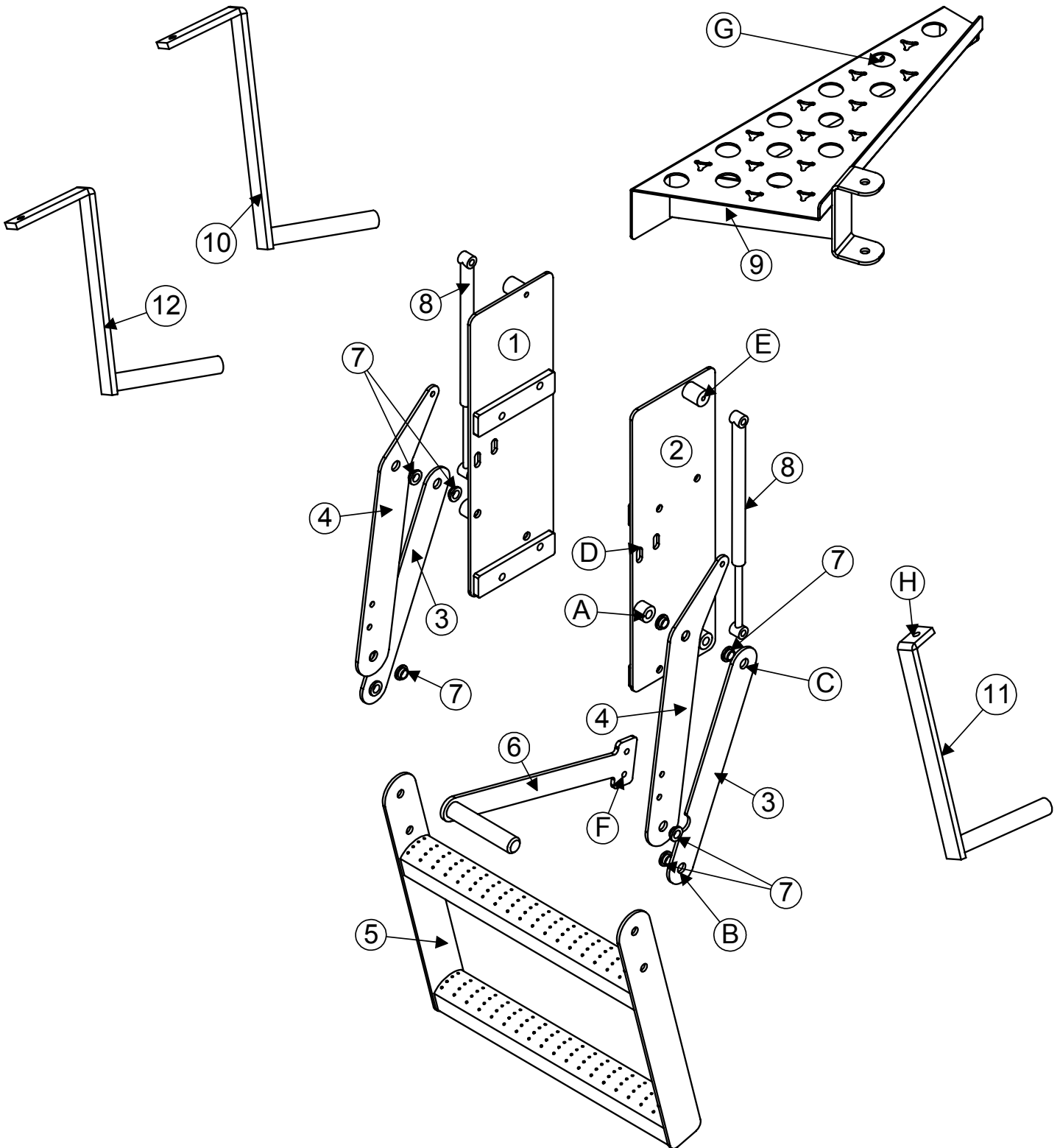

Model CH9010 Hillco Leveling System
For Serial Numbers CH9010-12001 thru CH9010-12999

LADDER COMPONENTS				
REF.	PART NO.	QTY.	PART NAME	NOTES
1	LA-252332	1	LM ASM, LEFT LADDER MNT	
2	LA-252342	1	LM ASM, RIGHT LADDER MNT	
3	LM-252262	2	LM PLATE, FOLDING LADDER LINK	
4	LM-252272	2	LM PLATE, UPPER ARM	
5	LA-252322	1	LM STEP ASM, FOLDING LADDER	
6	LA-248861	1	LM ASM, LADDER HANDLE	
7	LM-267981	8	FLANGED BUSHING	
8	MC-139251	2	GAS CHARGED LIFT SUPPORT	
NS	MC-134931	2	LIFT SUPPORT BRACKETS (PAIR)	
9	LA-253901	1	LM ASM, LADDER WEDGE	
FOR AFX 8010 COMBINES WITH SN PRIOR TO HAJ106401				
10	LA-251801	2	LM ASM, RH SIDE STEP SUPPORT	
FOR AFX 8010 COMBINES WITH SN HAJ106401 AND AFTER				
11	LA-255841	1	LM ASM, LH SIDE STEP SUPPORT	
12	LA-251802	1	LM ASM, RH SIDE STEP SUPPORT	
FOR AFX 8120/9120 COMBINES				
NS	LA-251802	2	LM ASM, RH SIDE STEP SUPPORT	
LADDER FASTENERS				
REF.	PART NO.	QTY.	PART NAME	WHERE USED
A	F-HC-12M050F	2	HC-8.8 M12 X 1.75 X 50	TOP SIDE PLATE PIVOTS
A	F-HNS-12ME	2	HN- 10.9 M12 X 1.75 STOVER	PIVOTS
B	F-HC-12M030F	4	HC-8.8 M12 X 1.75 X 30	MIDDLE PIVOTS
B	F-HNS-12ME	4	HN- 10.9 M12 X 1.75 STOVER	PIVOTS
C	F-HC-12M065F	2	HC-8.8 M12 X 1.75 X 65	BOTTOM SIDE PLT PIVOTS
C	F-HNS-12ME	2	HN- 10.9 M12 X 1.75 STOVER	PIVOTS
D	F-HC-10M040F	8	HC-8.8 M10 X 1.50 X 40	SIDE PLATE MOUNTS
D	F-HNS-10ME	8	HN-10.9 M10 X 1.50 STOVER	SIDE PLATE MOUNTS
E	F-HNJ-05C	2	HN5 5/16-18 JAM NUT	BALL STUD
E	F-LW-05	4	LW 5/16	BALL STUD
F	F-HC-08M025F	2	HC-8.8 M8 X 1.25 X 25	HANDLE
F	F-HNF-08MF	2	FLHN-8.8 M8 X 1.25	HANDLE
G	F-HCF-8M020E	3	FLHC-10.9 M8 X 1.25 X 20	WEDGE
G	F-HNF-08ME	3	FLHN-10.9 M8 X 1.25	WEDGE
H	F-HNF-10ME	2	FLHN-10.9 M10 X 1.50	LEFT SIDE STEP SUPPORT
H	F-HC-10M040F	1	HC-8.8 M10 X 1.50 X 40	LEFT SIDE STEP SUPPORT

LEVELING BOX

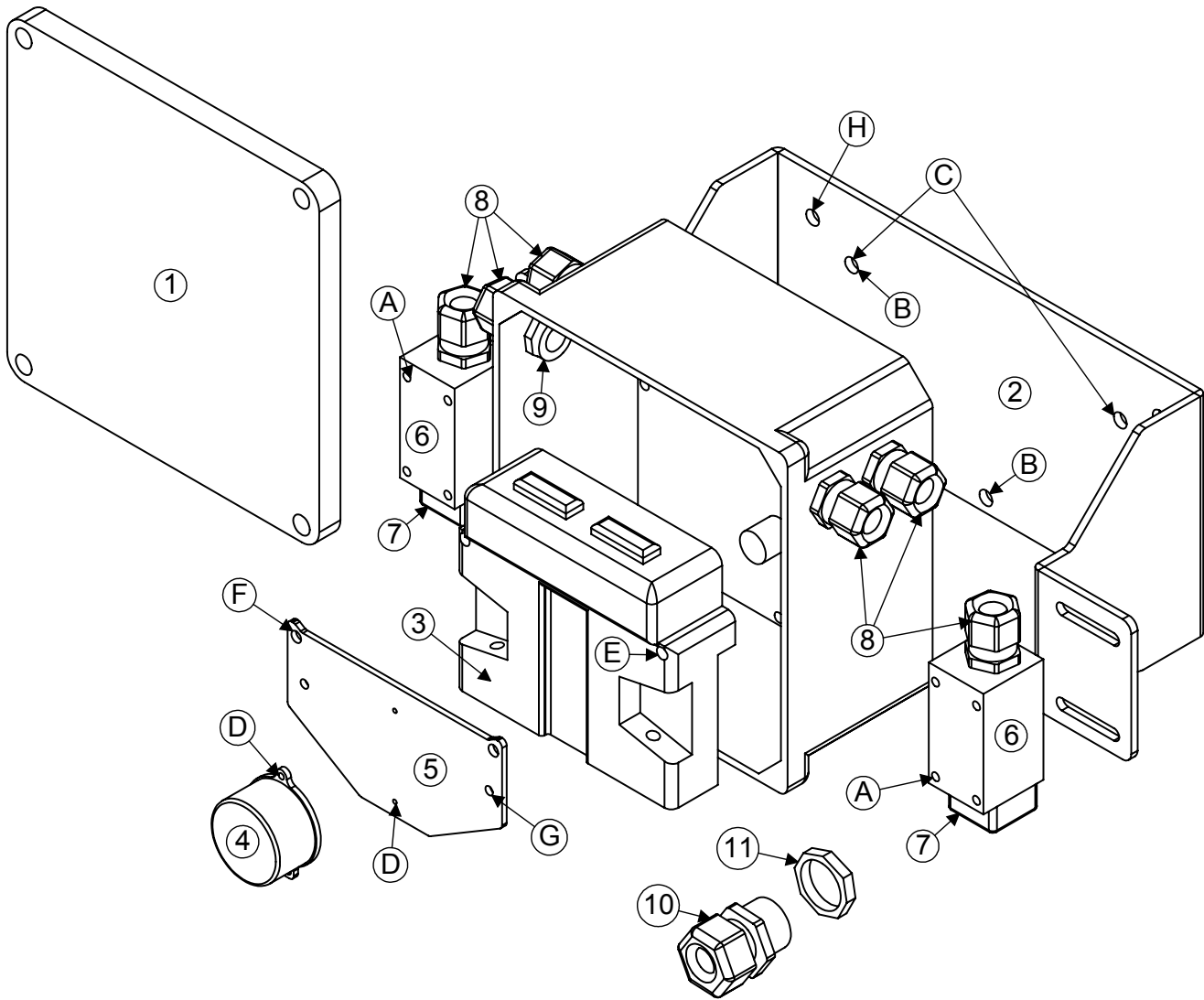

Model CH9010 Hillco Leveling System
For Serial Numbers CH9010-12001 thru CH9010-12999

MAIN ELECTRICAL BOX COMPONENTS				
REF.	PART NO.	QTY.	PART NAME	NOTES
ASM	LA-254472	1	EM ASM, CONTROLLER	
1	LM-260301	1	EM BOX, CONTROLLER MOUNT	
2	LP-251432	1	EM MOUNT, LEVELING BOX	
3	EC-141831	1	CONTROLLER	
4	LA-255821	1	EM ASM, CLINOMETER	SEE NOTE BELOW DIAGRAM
5	LM-255331	1	EM SHT, CLINOMETER MOUNT	
6	EC-100557	2	BODY, LIMIT SWITCH	
7	EC-100692	2	HEAD, LIMIT SWITCH STR PLUNGER	
8	EC-138781	8	STRAIN RELIEF, NYLON, BLK, 1/2 NPT	2 - ON ELECTRICAL CABLES THRU CAB
9	EC-142121	6	STRAIN RELIEF NUT, 1/2" NYLON, BLK	2 - ON ELECTRICAL CABLES THRU CAB
NS	EC-142101	1	CLAMP, HOSE 3/8" R/C W/ 3/8 HOLE	
NS	EC-142201	1	EXTRACTION TOOL, DEUTSCH	
ELECTRICAL BOX FASTENERS				
REF.	PART NO.	QTY.	PART NAME	WHERE USED
A	F-PHM-#10C28	8	PHMS 10-24 X 1-3/4	LIMIT SWITCH MNT
A	F-HNF-#10C	8	HN 10-24, FLNG SERR	LIMIT SWITCH MNT
B	F-HC5-04C12	3	HC5 1/4-20 X 3/4	PVC BOX TO BRACKET
B	F-LW-04	3	LW 1/4	PVC BOX TO BRACKET
C	F-HCF-08M020E	4	FLHC-10.9 M8 X 1.25 X 20	ELECTRICAL PLATE TO OC
C	F-HNF-08ME	4	FLHN-10.9 M8 X 1.25	ELECTRICAL PLATE TO OC
D	F-PHM-#6C06	2	PHMS #6-32 X 3/8	CLINOMETER MOUNT
E	F-PHM-04C24	2	PHMS 1/4-20 X 1-1/2	CONTROLLER TO PVC BOX
E	F-HNF-04C	2	FLHN 1/4-20 SERR	CONTROLLER TO PVC BOX
F	F-PHM-04C36	2	PHMS 1/4-20 X 2-1/4	GROUNDING PLATE MOUNTING
F	F-HNF-04C	2	FLHN 1/4-20 SERR	GROUNDING PLATE MOUNTING
G	F-PHM-#10C16	2	PHMS 10-24 X 3/4	GROUNDING PLATE GROUND
G	F-HNF-#10C	2	HN5 10-24, SERR	GROUNDING PLATE GROUND
G	F-HN-#10C	2	HN5 10-24	GROUNDING PLATE GROUND
H	F-LWE-05	1	LW 5/16, EXTERNAL STAR	EXTERNAL GROUND WIRE

MONITOR DISPLAY

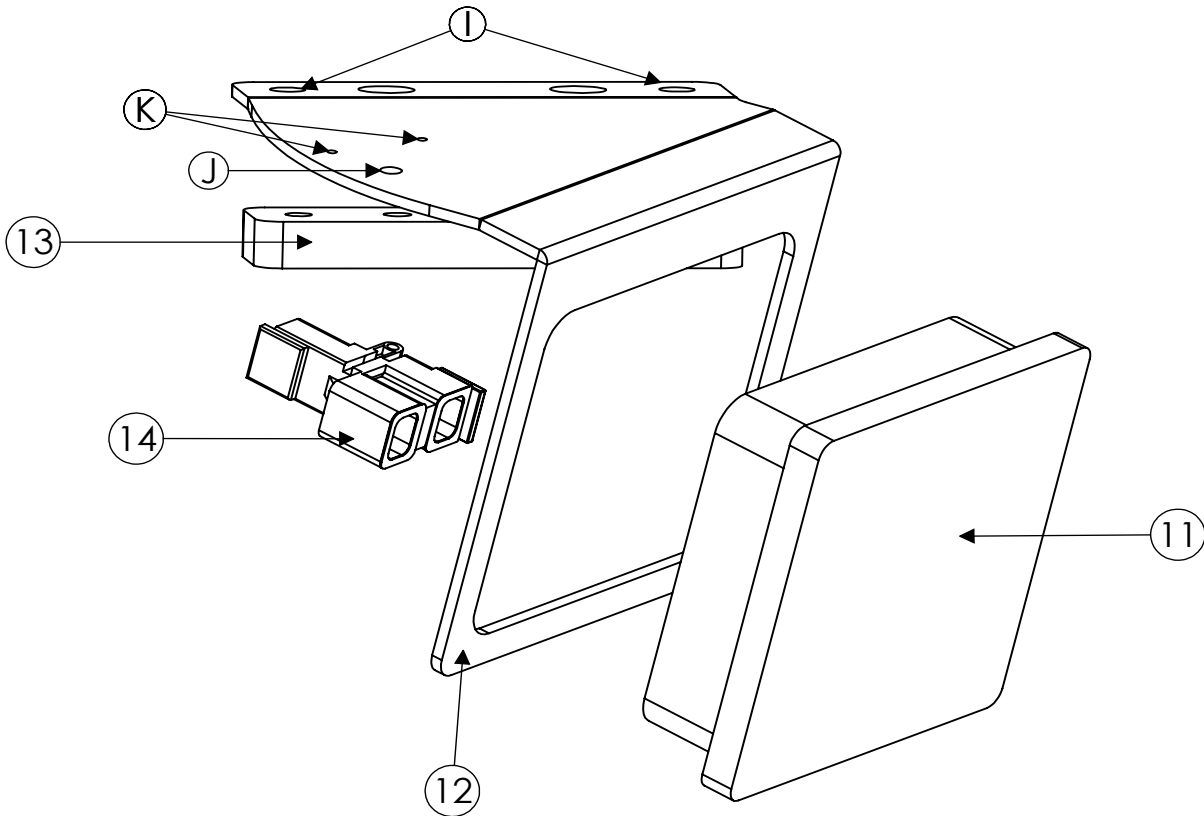

CAB CONTROL MONITOR COMPONENTS				
REF.	PART NO.	QTY.	PART NAME	NOTES
ASM	LA-270791	1	EM ASM, CAB CONTROL MONITOR	
10	LM-270761	1	EM MOUNT, DISPLAY	
11	LM-265511	1	EM MOUNT, DISPLAY SPACER	
12	EC-146461	1	GRAPHICAL TERMINAL, S-D DP200	
13	EC146531	1	Y CONNECTOR, BLACK	
NS	EC-146481	1	BUZZER, PIEZO ELECTRIC	
NS	EC-146881	1	MINI FUSE HOLDER, ATM	
NS	EC-146891	1	MINI BLADE FUSE, ATM, 5AMP	
NS	ET-SP-16	1	FEMALE SPADE	
NS	ET-ST-2005	1	STUD 5/16, 20GA	
CAB CONTROL MONITOR FASTENERS				
REF.	PART NO.	QTY.	PART NAME	WHERE USED
I	F-PHM-#10C08	1	PHMS 10-24 X 1/2	Y-CONNECTOR MOUNTING
I	F-HN-#10C	1	HN5 10-24	Y-CONNECTOR MOUNTING
J	F-HN-#2C	2	HN #2-56	FASTEN PIEZO BUZZER TO MONITOR MOUNT
J	F-PHM-#2C05	2	PHMS #2-56 X 5/16	FASTEN PIEZO BUZZER TO MONITOR MOUNT
K	19M7932	2	FLHC-10.9 M8 X 1.25 X 16	GRAPHICAL TERMINAL MOUNTING
K	37M7104	2	SCREW, SELF-TAPPING, M6 X 1.00 X 35	GRAPHICAL TERMINAL MOUNTING
K	37M7089	1	SCREW, SELF-TAPPING, M6 X 1.00 X 12	3/8" HOSE CLAMP

Model CH9010 Hillco Leveling System
 For Serial Numbers CH9010-12001 thru CH9010-12999

REMOTE SWITCH

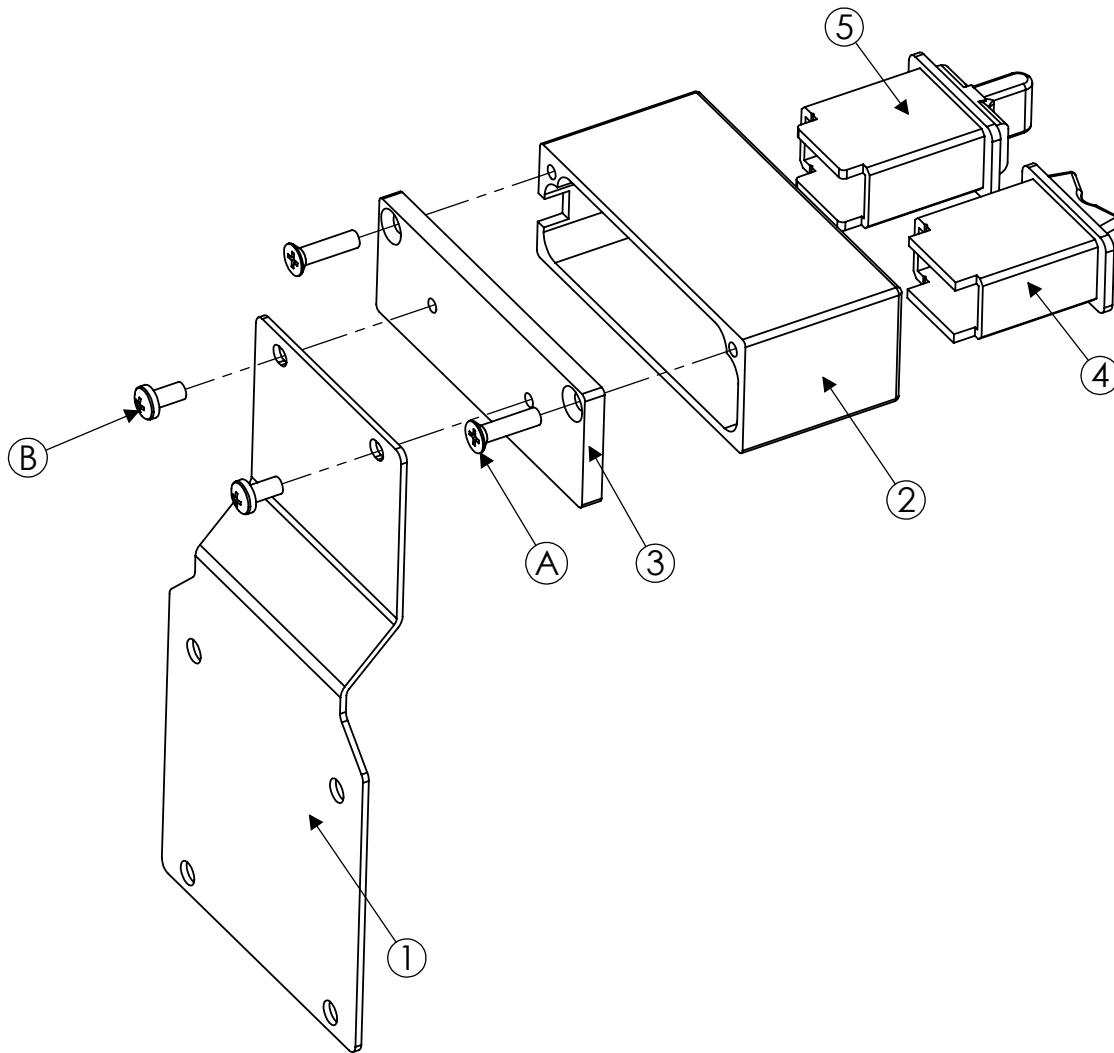

REMOTE SWITCH				
REF.	PART NO.	QTY.	PART NAME	WHERE USED
ASM	LA-286352	1	REMOTE SWITCH BOX	FOR 8120/9120 (YBG213601-)
ASM	LA-286351	1	REMOTE SWITCH BOX	FOR 8120/9120 (-YBG213600)
1	LP-286272	1	SWITCH MOUNT	FOR 8120/9120 (YBG213601-)
1	LP-286271	1	SWITCH MOUNT	FOR 8120/9120 (-YBG213600)
2	LM-286371	1	EM BOX, REMOTE SWITCH	
3	LM-286381	1	EM COVER, REMOTE SWITCH	
4	EC-150121	1	SWITCH, DPDT, ON-NONE-ON, W/ ROCKER	
5	EC-150031	1	SWITCH, DPDT, (ON)-OFF-(ON), W/ PADDLE ACTUATOR	
REMOTE SWITCH FASTENERS				
REF.	PART NO.	QTY.	PART NAME	WHERE USED
A	F-FHM-05M020F	2	FLAT HEAD MACHINE SCREW M5 X 0.8 X 20	SECURES COVER PLATE TO BOX
B	F-PHM-05M010F	2	PAN HEAD MACHINE SCREW M5 X 0.8 X 10	SECURES BOX TO MOUNTING PLATE

ELECTRICAL CONNECTORS & CABLES

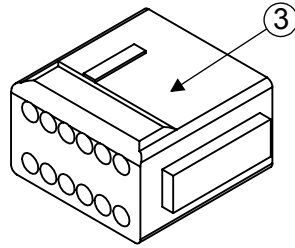
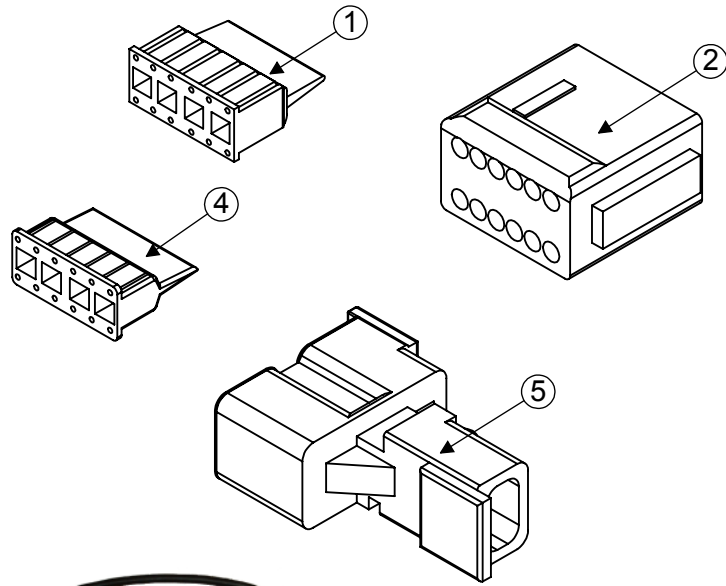

#6 LA-255631
EM CABLE ASM, LIMIT SWITCH



#10 LA-270771
EM CABLE ASM, CAB TO BOX



#7 LA-255631
EM CABLE ASM, BOX TO VALVE

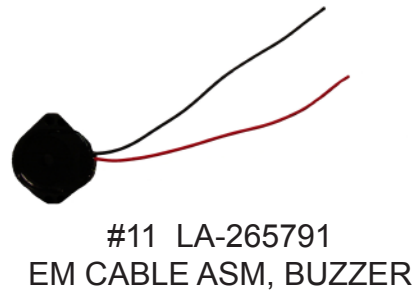

#11 LA-265791
EM CABLE ASM, BUZZER



#8 LA-261191
EM CABLE ASM, CLINOMETER



#12 LA-270781
EM CABLE ASM, POWER AND GROUND



#9 LA-270801
EM CABLE ASM, MANIFOLD



#13 LA-286361
EM CABLE ASM, REMOTE SWITCH

Model CH9010 Hillco Leveling System
For Serial Numbers CH9010-12001 thru CH9010-12999

ELECTRICAL CONNECTORS				
REF.	PART NO.	QTY.	PART NAME	NOTES
1	EC-141741	4	DTM SERIES, 12-SOCKET WEDGE	
2	EC-141751	3	DTM SERIES, 12-SOCKET PLUG - GRAY	
3	EC-141761	1	DTM SERIES, 12-SOCKET PLUG - BLACK	
4	EC-143271	1	DTM SERIES, 12-PIN WEDGE	
5	EC-146531	1	Y-CONNECTOR, BLACK	
NS	EC-139641	4	CONNECTOR, PARALLEL, 16-14 GA	
NS	EC-141771	7	DTM SERIES, SOCKET CONTACT, STAMPED	
NS	EC-141781	10	DTM SERIES, PIN CONTACT, STAMPED	
NS	EC-143261	1	DTM SERIES, 12- PIN RECEPTACLE	
NS	EC-145671	13	DTM SERIES, PLUG, SEALING	
NS	EC-146511	2	PLUG, GRAY, 2-SOCKET	
NS	EC-146521	2	WEDGE, BLACK, 2-SOCKET W/B KEY	
NS	EC-146541	1	PLUG, GRAY, W/120 OHM RESISTOR	
NS	EC-146581	20	DTM SERIES, SOCKET CONTACT, SOLID	
NS	EC-146591	2	DTM SERIES, PIN CONTACT, SOLID	
NS	EC-146601	1	RECEPTACLE, GRAY, 2-PIN	
NS	EC-146611	1	WEDGE, BLACK, 2-PIN W/B KEY	
NS	ET-ST-20#10	6	TERMINAL, RING, #10, 20 GA., NON-INSULATED	
CABLE ASSEMBLIES				
REF.	PART NO.	QTY.	PART NAME	NOTES
6	LA-255631	2	EM CABLE ASM, LIMIT SWITCH	
7	LA-249103	1	EM CABLE ASM, BOX TO VALVE	
8	LA-261191	1	EM ASM, CLINOMETER	
9	LA-270801	1	EM CABLE ASM, MANIFOLD	
..	LA-270811	1	EM CABLE ASM, RWA SIGNAL	<i>INCLUDED IN LA-270801</i>
..	LA-268341	1	EM CABLE ASM, LEVELING MANIFOLD	<i>INCLUDED IN LA-270801</i>
NS	LA-265481	1	EM CABLE ASM, SENSOR ADAPTER	
10	LA-270771	1	EM CABLE ASM, CAB TO BOX	
11	LA-265791	1	EM CABLE ASM, BUZZER	
12	LA-270781	1	EM CABLE ASM, POWER & GROUND	
13	LA-286361	1	EM CABLE ASM, REMOTE SWITCH	

HYDRAULICS COMPONENTS

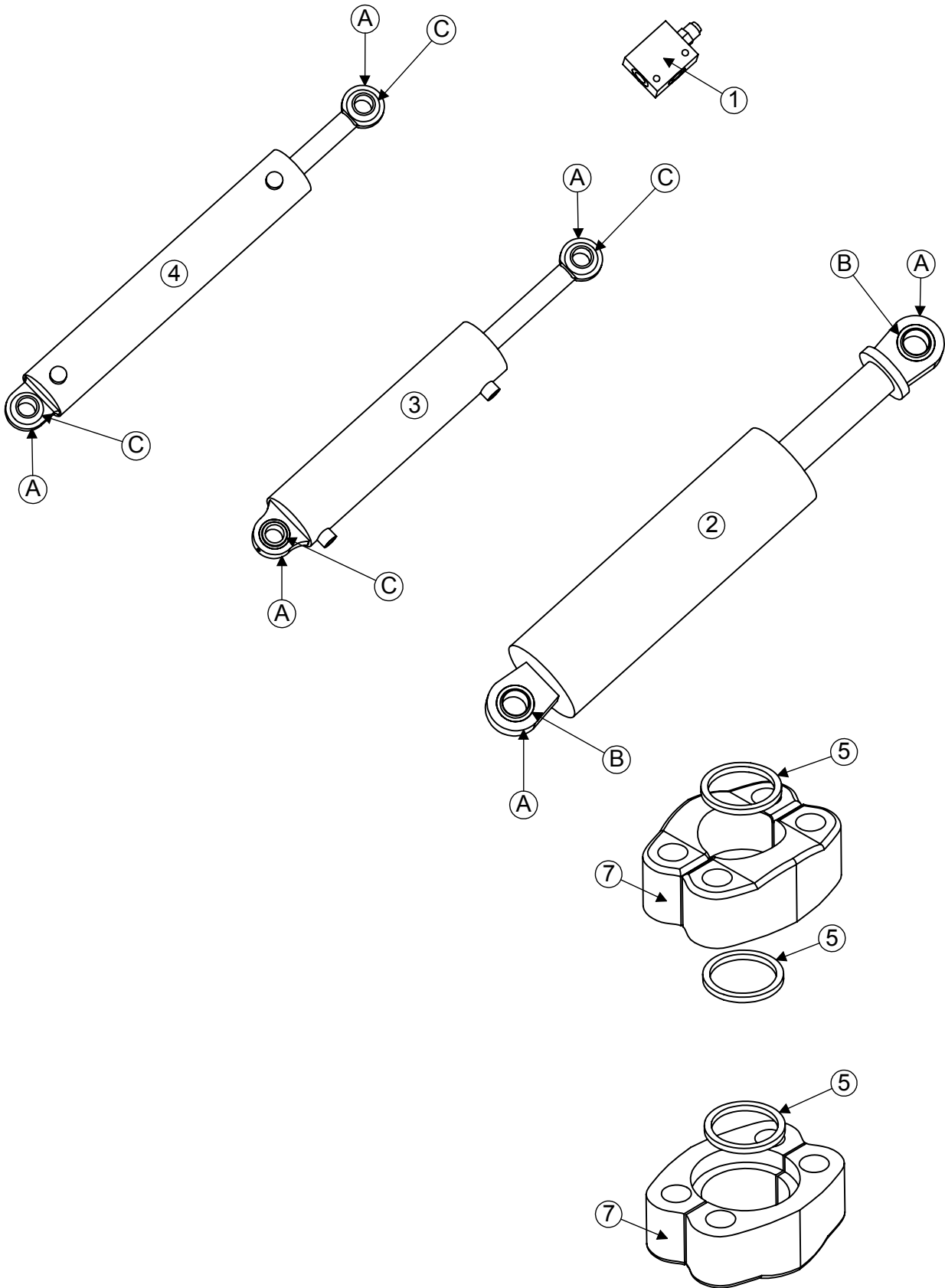

Model CH9010 Hillco Leveling System
For Serial Numbers CH9010-12001 thru CH9010-12999

COUNTERBALANCE VALVE AND CYLINDERS				
REF.	PART NO.	QTY.	PART NAME	NOTES
1	HC-139151	2	VALVE, 3-PORT COUNTERBALANCE	
..	HC-139181	2	BODY, COUNTERBALANCE VALVE	
..	HC-139161	2	CARTRIDGE, COUNTERBALANCE VALVE	
NS	HC-140361	2	SEAL KIT, COUNTERBALANCE VALVE	
2	HC-147521	2	CYLINDER, MAIN	
NS	HC-135221	2	SEAL KIT, MAIN CYLINDER	
3	HC-147501	1	CYLINDER, MASTER	
NS	HC-134201	1	SEAL KIT, MASTER CYLINDER	
4	HC-147491	1	CYLINDER, SLAVE	
NS	HC-141281	1	SEAL KIT, SLAVE CYLINDER	

HYDRAULIC FASTENERS				
REF.	PART NO.	QTY.	PART NAME	WHERE USED
A	F-SSS-04F04	6	SET SCREW, 1/4-28 X 1/4	ALL CYLINDERS
B	MC-150881	4	1 3/8" BEARING, SEALED SPHERICAL	
C	MC-150871	4	1" BEARING, SEALED SPHERICAL	

CODE 62 SPLIT FLANGE CONNECTOR KIT				
REF.	PART NO.	QTY.	PART NAME	NOTES
ASM	LA-254951	2	KIT, HOSE COUPLER, 1-1/4" CODE 62	
ONE CODE 62 SPLIT FLANGE CONNECTOR KIT ASSEMBLY INCLUDES:				
5	HC-147621	3	O-RING, CODE 62, 1-1/4"	
6	HC-148301	1	HM PLT, CODE 62 (#20)	
7	LM-273011	4	HM FLANGE, CODE 62, #20	
NS	F-HC-14M090E	4	HC-10.9 M14 X 2.00 X 90 PLT	
NS	F-HNS-14ME	4	HN-10.9 M14 X 2.00 STOVER PLT	

LEVELING MANIFOLD

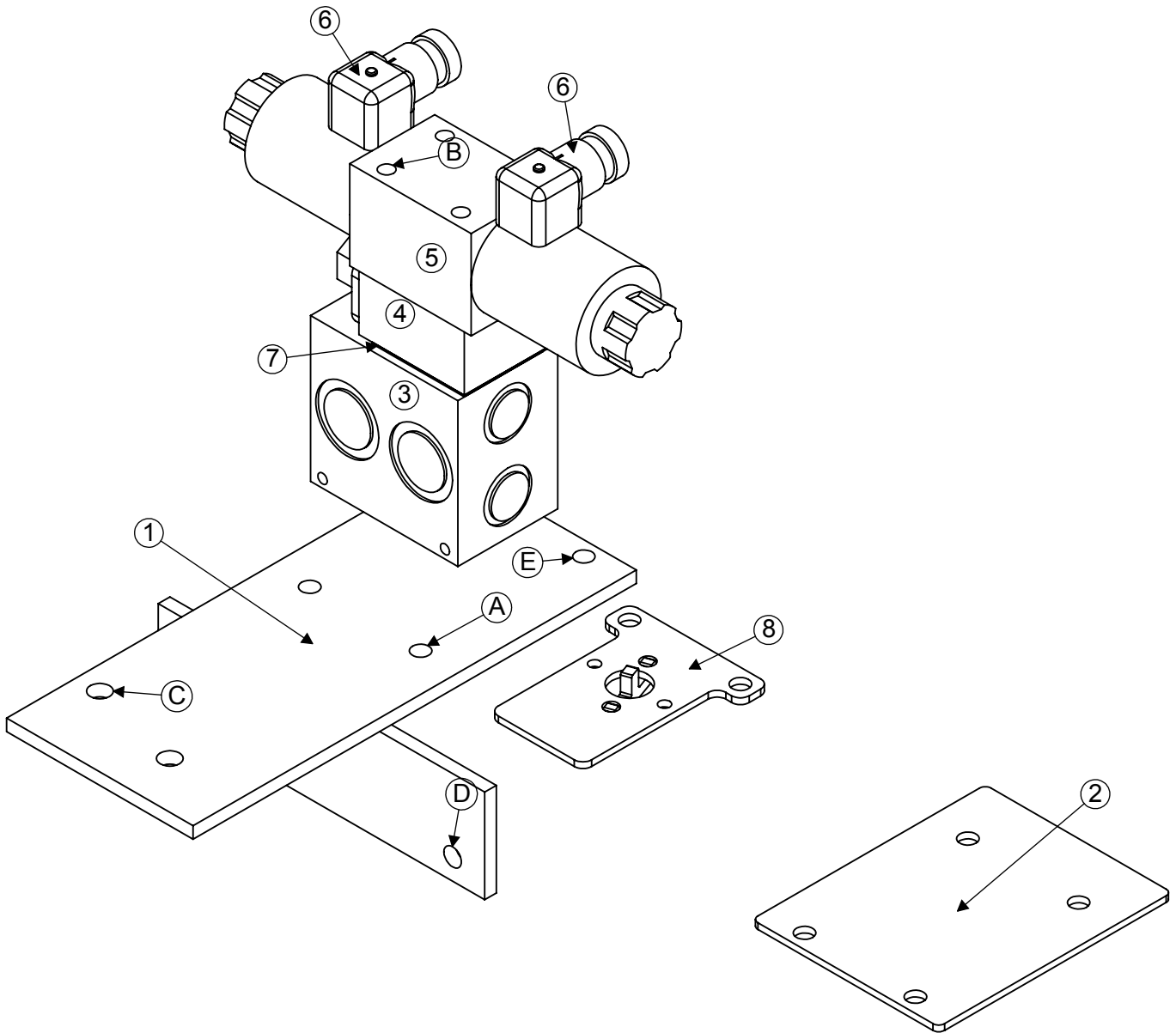

Model CH9010 Hillco Leveling System
For Serial Numbers CH9010-12001 thru CH9010-12999

MANIFOLD COMPONENTS				
REF.	PART NO.	QTY.	PART NAME	NOTES
ALL AFX 8010 COMBINES				
1	LA-251611	1	HM PLATE, MANIFOLD MOUNT	
ALL AFX 8120/9120 COMBINES				
2	LP-251602	1	HM FLAT, MANIFOLD MOUNT	
ALL COMBINES				
3	HC-138861	1	MANIFOLD, SINGLE STATION	
4	HC-101264	1	SHUTTLE ASM, LOAD SENSE	
..	HC-101021	1	CARTRIDGE, LOAD SENSE VALVE	
..	HC-101022	1	BODY, LOAD SENSE VALVE	
NS	HC-102082	1	SEAL KIT, LOAD SENSE SHUTTLE ASM	
5	HC-140411	1	VALVE, DIRECTIONAL CONTROL, PROPORTIONAL	
NS	LM-250092	1	ORIFICE, .1875, DIRECTIONAL CONTROL VALVE	
NS	HC-142731	1	SEAL KIT, DIRECTIONAL CONTROL VALVE	
6	HC-140291	2	PLUG, DIN, LIGHTED	
7	HC-142761	1	SUBPLATE	
8	LA-259951	1	EM ASM, TILT SENSOR MOUNT	
MANIFOLD FASTENERS				
REF.	PART NO.	QTY.	PART NAME	WHERE USED
ALL AFX 80 10 COMBINES				
A	F-HCF-08M020E	4	FLHC-10.9 M8 X 1.25 X 20	SECURES MANIFOLD TO MOUNTING PLATE
A	F-HNF-08ME	4	FLHN-10.9 M8 X 1.25	SECURES MANIFOLD TO MOUNTING PLATE
ALL AFX 8120/9120 COMBINES				
NS	F-HCF-08M020E	2	FLHC-10.9 M8 X 1.25 X 20	BOTTOM MANIFOLD MOUNTING BOLTS
NS	F-HCF-08M030E	2	FLHC-10.9 M8 X 1.25 X 30	TOP MANIFOLD MOUNTING BOLTS
NS	F-HNF-08ME	4	FLHN-10.9 M8 X 1.25	SECURES MANIFOLD TO MOUNTING PLATE
ALL COMBINES				
B	F-SHC-#10C52	4	SHCS 10-24 X 3-1/4	MANIFOLD ASM
B	F-LW-#10	4	LW #10	MANIFOLD ASM
C	F-HCF-10M025E	2	FLHC-10.9 M10 X 1.50 X 25	MANIFOLD ASM TO COMBINE
C	F-HNF-10ME	2	FLHN-10.9 M10 X 1.50	MANIFOLD ASM TO COMBINE
D	F-HCF-08M025E	2	FLHC-10.9 M8 X 1.25 X 25	MANIFOLD ASM TO COMBINE
D	F-HNF-08ME	2	FLHN-10.9 M8 X 1.25	MANIFOLD ASM TO COMBINE
E	F-PHM-#10C28	2	PHMS 10-24 X 1-3/4	LATERAL TILT SENSOR TO MOUNT
E	F-HNF-#10C	2	HN 10-24, FLNG SERR	LATERAL TILT SENSOR TO MOUNT

Model CH9010 Hillco Leveling System
For Serial Numbers CH9010-12001 thru CH9010-12999

HYDRAULIC HOSES

LEVELING AND TRIM				
REF.	PART NO.	QTY.	PART NAME	WHERE USED
NS	LA-140521	2	1/4" 100R2 HOSE 14" #6 FORS 90 X #6 FORS	INNER MAIN ROD TO COUNTERBALANCE VALVE PORT #3 (LEFT & RIGHT)
NS	LA-140531	1	1/2" 100R2 HOSE 104" #8 FORS 90 X #8 FORS STR	LEVELING PORT "A" TO COUNTERBALANCE VALVE PORT #2 RIGHT
NS	LA-140541	1	1/2" 100R2 HOSE 184-1/2" #8 FORS 90° X #8 FORS STR	LEVELING PORT "B" TO COUNTERBALANCE VALVE PORT #2 RIGHT
NS	LA-133631	2	1/2" 100R2 HOSE 82" #8 FORS X #8 FORS	OUTER MAIN ROD TO COUNTERBALANCE VALVE PORT #2 (LEFT & RIGHT)
NS	LA-140561	1	1/4" 100R2 HOSE 116" #6 FORS X #6 FORS	MASTER CYLINDER BASE TO SLAVE CYLINDER BASE
NS	LA-140571	1	1/4" 100R2 HOSE 138" #6 FORS X #6 FORS	MASTER CYLINDER ROD TO SLAVE CYLINDER ROD
NS	LA-140581	1	1/4" 100R2 HOSE 111" #6 FORS X #6 FORS	FIELD TRACKER "HEAD" PORT TO MASTER BASE
NS	LA-140591	1	1/4" 100R2 HOSE 104" #6 FORS X #6 FORS	FIELD TRACKER "ROD" PORT TO MASTER ROD
NS	HC-133541	2	ABRASION SLEEVE, NYLON -- 2.19" ID X 32"	HOSES TO TRIM VALVE AND SLAVE CYL
NS	HC-133111	1	SLEEVE, NYLON ABRASION - 2.19 ID X 32 IN	TRIM HOSES AT SLAVE CYLINDER
NS	LA-140492	1	1/4" 100R2 HOSE 35-1/2" #6 FORS X #4 FORS	LOAD SENSE LINE
NS	LA-140502	1	5/8" 100R2 HOSE 28" #10 FORS X #10 FORS	LEVELING VALVE PRESSURE HOSE
NS	LA-140512	1	5/8" 100R1 HOSE 26" #10 FORS X #10 FORS	LEVELING VALVE RETURN HOSE
GREASE				
NS	LA-140662	1	3/16 R1 GREASE HOSE 47" 1/8 MPT X 1/8 MPT	MAIN PIVOT PIN TO LH BULKHEAD BTM
NS	LA-141911	1	3/16 R1 GREASE HOSE 25" 1/8 MPT X 1/8 MPT	MASTER BASE TO RH BULKHEAD TOP
NS	LA-141921	1	3/16 R1 GREASE HOSE 70" 1/8 MPT X 1/8 MPT	MASTER ROD TO RH BULKHEAD BTM
BRAKE HOSES				
NS	LA-140602	2	1/4" TITFLEX HOSE 83" #3 MINV X #3 MINV WITH M10-1.0 X #3 FINV ADAPTER ON EACH END	LEFT & RIGHT BRAKE HOSES
HYDRO HOSES				
FOR AFX 8010 COMBINES				
NS	LA-140551	2	1-1/4" 6000 PSI WP 82" CODE 62 FLANGE STR. X CODE 62 FLANGE 90°	HYDROSTATIC HOSE EXTENSIONS
FOR AFX 8120/9120 COMBINES				
NS	LA-140551	1	1-1/4" 6000 PSI WP 82" CODE 62 FLANGE STR. X CODE 62 FLANGE 90°	BOTTOM HYDROSTATIC HOSE EXTENSIONS
NS	LA-147691	1	1-1/4" 6000 PSI WP 78" CODE 62 FLANGE STR. X CODE 62 FLANGE 90°	TOP HYDROSTATE HOSE EXTENSION
CASE DRAIN HOSES				
FOR AFX 8120 SN (-Y9G206185); 9120 SN (-Y9G206185)				
NS	LA-274001	1	1" 100RD HOSE 68" #16 FORS 90° X #16 MORS	CASE DRAIN HOSE EXTENSION
FOR AFX 8120 SN (Y9G206186-); 9120 SN (Y9G206186-)				
NS	LA-274681	1	1" 100R2 HOSE 110" #16 FORS 90° X #16 FORS	CASE DRAIN HOSE EXTENSION

Model CH9010 Hillco Leveling System
For Serial Numbers CH9010-12001 thru CH9010-12999

HYDRAULIC ADAPTERS

LEVELING MANIFOLD				
REF.	PART NO.	QTY.	PART NAME	WHERE USED
NS	HA-M-6MF6FF	1	#6 ORS SWIVEL NUT RUN TEE	LOAD SENSE LINE ON COMBINE
NS	HA-M-16FF16MF	2	#16 ORS SWIVEL NUT RUN TEE	PRESSURE AND TANK LINES ON COMBINE
NS	HA-S-16FF10MF	2	#16 FORS X # 10 MORS REDUCER W/ NUT	PRESSURE AND TANK LINES ON COMBINE
NS	HA-E-10MO	2	#10 MORB ALLEN HEAD PLUG ZERO-LEAK	"P" & "T" PORTS
NS	HA-L-10MF10MO	1	#10 MORS X #10 MORB 90°	"T" PORT
NS	HA-S-10MF10MO	1	#10 MORS X #10 MORB STR	"P" PORT
NS	HA-L-10FF10MF	1	#10 FORS X #10 MORS 90°	"P" PORT
NS	HA-L-8MF8MO	1	#8 MORS X #8 MORB 90°	"A" LEVELING PORT
NS	HA-L-8FF8MF	1	#8 MORS X #8 FORS 90°	"B" LEVELING PORT
NS	HA-S-8MF8MO	1	#8 MORS X #8 MORB STR	"B" LEVELING PORT
NS	HA-S-4MF4MO	1	#4 MORS X #4 MORB STR	LOAD SENSE SHUTTLE
CASE FIELD TRACKER VALVE				
NS	HA-L-6FF6MF	2	#6 FORS X # 6 MORS 90°	FIELD TRACKER VALVE
MAIN CYLINDER AND COUNTERBALANCE VALVE				
NS	HA-L-8MO8MO	2	#8 MORB X #8 MORB 90°	LEFT & RIGHT COUNTERBALANCE VALVE PORT #1 TO MAIN CYL BASE
NS	HA-L-8MF8MO	2	#8 MORS X #8 MORB 90°	LEFT & RIGHT OUTER MAIN CYLINDER ROD
NS	HA-L-6MF8MO	2	#6 MORS X #8 MORB 90°	LEFT & RIGHT INNER MAIN CYINDER ROD
NS	HA-T-8MF8MO	2	#8 MORS X #8 MORB STR THREAD RUN TEE	LEFT & RIGHT COUNTERBALANCE VALVE PORT #2
NS	HA-L-6MF6MO	2	#6 MORS X # 6 MORB 90°	LEFT & RIGHT COUNTERBALANCE VALVE PORT #3
NS	HC-141931	2	ZERK, GREASE 1/4-28 45°	BASE END OF MAIN LEVELING CYLINDERS
MASTER AND SLAVE CYLINDERS				
NS	HA-Q-6MF6MO	2	#6MORS X #6MORB STR THREAD BRANCH TEE	MASTER BASE AND ROD PORTS
NS	HA-L-6MF6MO	1	#6 MORS X #6 MORB 90°	SLAVE ROD PORT
NS	HA-F-6MF6MO	1	#6 MORS X #6 MORB 45°	SLAVE BASE PORT
NS	HC-135771	1	1/4-28 MALE X 1/8 FPT 90°	BASE END OF MASTER CYLINDER
NS	HC-135881	1	1/4-28 MALE X 1/8 FPT STR	ROD END OF MASTER CYLINDER
GREASE				
NS	HA-S-2FP2MN	3	1/8" NPSM X 1/8" FPT BULKHEAD CONNECTOR	GREASE BULKHEAD MOUNT
NS	HA-NJ-2FN	3	1/8 NPSM BULKHEAD LOCKNUT	BULKHEAD CONNECTORS
NS	HA-L-2FP2MP	1	1/8 MPT 90 STREET EL	MAIN PIVOT PIN
NS	HC-138011	1	ZERK, GREASE 1/4-28 STR	MAIN PIVOT PIN
NS	HC-141231	1	ZERK, GREASE 1/8 MPT, 45°	DROP AXLE PIVOT PIN

MISCELLANEOUS



1) LL-133741



2) LL-151061

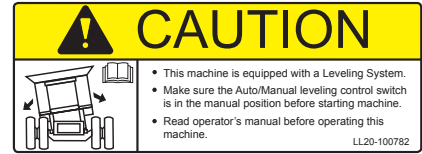

3) LL20-100782



4) LL20-100783



5) LL20-100784



6) LL20-100785



7) LL20-100786

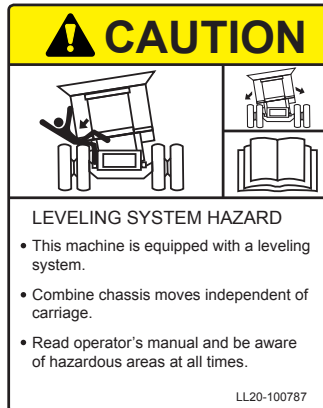

8) LL20-100787



9) LL20-100788

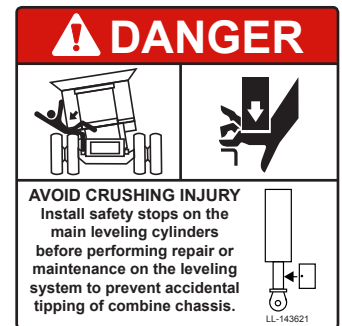

10) LL-143621



11) LL-141012

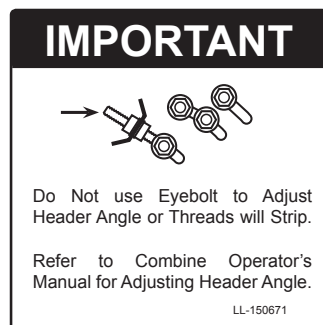

12) LL-150571

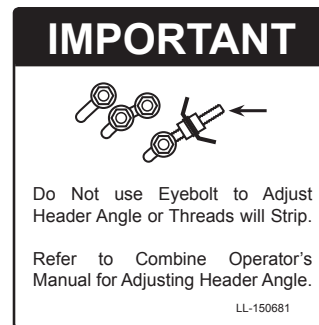

13) LL-150581

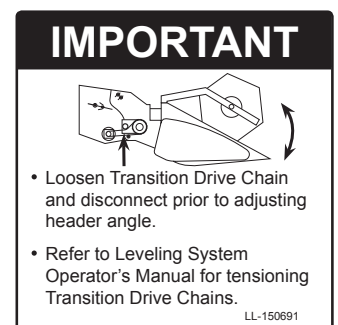

14) LL-150591

Model CH9010 Hillco Leveling System
For Serial Numbers CH9010-12001 thru CH9010-12999

DOCUMENTS AND LABELS				
REF.	PART NO.	QTY.	PART NAME	NOTES
1	LL-133741	2	LABEL, GREASE 50 HRS	RH AND LH MAIN LEV CYL BOTTOM
1	LL-133741	1	LABEL, GREASE 50 HRS	BY BASE END OF SLAVE CYLINDER
1	LL-133741	2	LABEL, GREASE 50 HRS	REAR FACE 12" ON BOTH SIDES OF PIVOT PIN
1	LL-133741	2	LABEL, GREASE 50 HRS	RH AND LH BULKHEAD MOUNT
2	LL-151061	2	DECAL, CASE HILLSIDE LEVELING SYSTEM	SIDE PANELS ON COMBINE
3	LL20-100782	1	CAUTION LEVELING SYSTEM CAB	WINDOW IN CAB
4	LL20-100783	2	DANGER, CRUSHING HAZARD	FRONT UC LEFT & RIGHT
4	LL20-100783	2	DANGER CRUSHING HAZARD	SIDE OF COMBINE ABOVE REAR TIRES
5	LL20-100784	2	DANGER PINCH POINT	RH & LH UPPER TRANS FACE PLT
6	LL20-100785	1	CAUTION MOVING STEP	COMBINE LADDER CHANNEL
7	LL20-100786	1	WARNING, ELECTRONIC CRUSHING HAZARD	FRONT OF CONTROL BOX
8	LL20-100787	2	CAUTION LEVELING SYSTEM HAZARD	CLEAN GRAIN ELEVATOR (RH); SCREEN (LH)
9	LL20-100788	3	DANGER HYDRAULIC HAZARD	1- EA MAIN CYLINDER
9	LL20-100788	1	DANGER HYDRAULIC HAZARD	ABOVE HYDRAULIC MANIFOLD
10	LL-143621	2	DANGER, AVOID CRUSHING INJURY	REAR OF UC NEAR THE SAFETY STOP MNTS
11	LL-141012	2	DECAL, ROCK TRAP WARNING	BY ROCK TRAP HANDLE AND ON SHIELD ABOVE HANDLE
12	LL-150671	1	LABEL, EYEBOLT LEFT	BELOW LEFT EYEBOLT MOUNT
13	LL-150681	1	LABEL, EYEBOLT RIGHT	BELOW RIGHT EYEBOLT MOUNT
14	LL-150691	1	LABEL, HEADER ANGLE	ON RH SIDE TT ASM NEAR TOP ADJ BOLTS
NS	EC-150131	1	DECAL, REMOTE SWITCH BOX	
NS	LL-141011	2	DECAL, ROCK TRAP WARNING	BY ROCK TRAP HANDLE AND ON SHIELD ABOVE HANDLE
NS	LL-239412	1	LABEL, STEERING WHEEL	TIED TO STEERING WHEEL DURING INSTALLATION
NS	LL-274401	1	LABEL, LIMIT SWITCH WARNING	LIMIT SWITCH
NS	LA-255951	1	PLATE, SERIAL NUMBER	LEFT REAR OF UNDERCARRIAGE
NS	D-111212CMA01A	1	CH9010 OPERATORS MANUAL	
NS	D-050322DJC01C	1	DEALER PDI CHECKLIST	
NS	D-050124DJC01B	1	FIPDI CHECKLIST	
NS	D-120623CMA01	1	MANUAL, PARTS	
MISCELLANEOUS COMPONENTS				
REF.	PART NO.	QTY.	PART NAME	NOTES
NS	EC-142101	2	CLAMP, HOSE, R/C, 3/8	BRAKE HOSES
NS	HC-143601	5	CLAMP, HOSE 1-1/8" R/C W/ 3/8 HOLE	HEADER TRIM HOSES ON FEEDER HOUSE
FOR AFX 8120/9120 COMBINES				
NS	MC-135631	2	CLAMP, HOSE 1-1/2" R/C 3/8 HOLE	CASE DRAIN HOSE
NS	MC-135781	1	CLAMP, HOSE 2" R/C 3/8 HOLE	CASE DRAIN HOSE
NS	F-HCF-8M020E	1	FLHC-10.9 M8 X 1.25 X 20 PLT	HOSE CLAMPS ON CASE DRAIN HOSES
NS	F-HNF-08ME	1	FLHN-10.9 M8 X 1.25 PLT	HOSE CLAMPS ON CASE DRAIN HOSES
NS	MC-145941	2	HD STRAP, 2' TIE DOWN	GULL WING DOORS

Model CH9010 Hillco Leveling System
For Serial Numbers CH9010-12001 thru CH9010-12999

Hillco Technologies, Inc.
107 1st Avenue
Nezperce, Idaho 83543

Phone	800-937-2461
	208-937-2461
Fax	208-937-2280

www.hillcotechnologies.com
email: support@hillcotechnologies.com